

TRUSS GEOMETRY AND CONDITIONS SHOWN ARE FOR ILLUSTRATION ONLY.

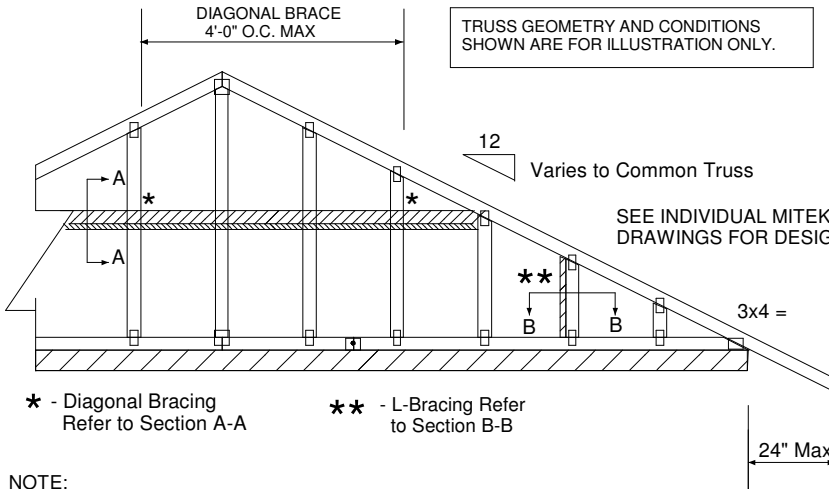

\* - Diagonal Bracing Refer to Section A-A  
 \*\* - L-Bracing Refer to Section B-B

PROVIDE 2x4 BLOCKING BETWEEN THE FIRST TWO TRUSSES AS NOTED. TOENAIL BLOCKING TO TRUSSES WITH (2) - 10d NAILS AT EACH END. ATTACH DIAGONAL BRACE TO BLOCKING WITH (5) - 10d NAILS.

(4) - 8d (0.131" X 2.5") NAILS MINIMUM, PLYWOOD SHEATHING TO 2x4 STD SP BLOCK

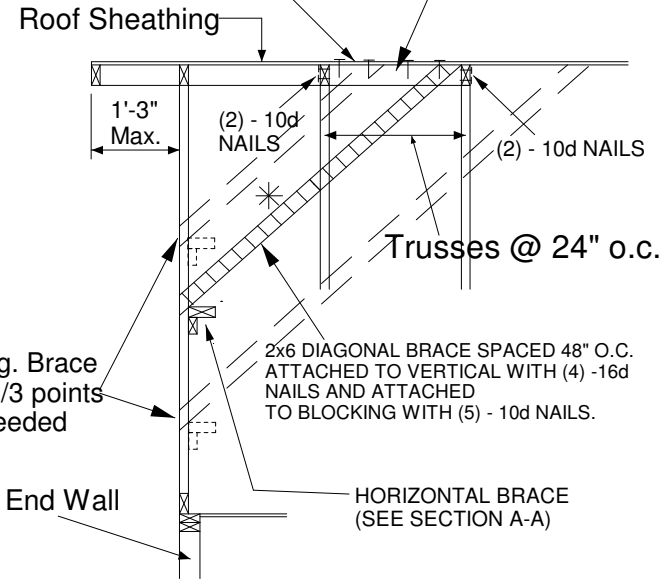

- NOTE:
1. MINIMUM GRADE OF #2 MATERIAL IN THE TOP AND BOTTOM CHORDS.
  2. CONNECTION BETWEEN BOTTOM CHORD OF GABLE END TRUSS AND WALL TO BE PROVIDED BY PROJECT ENGINEER OR ARCHITECT.
  3. BRACING SHOWN IS FOR INDIVIDUAL TRUSS ONLY. CONSULT BLDG. ARCHITECT OR ENGINEER FOR TEMPORARY AND PERMANENT BRACING OF ROOF SYSTEM.
  4. "L" BRACES SPECIFIED ARE TO BE FULL LENGTH. GRADES: 2x4 No 3/STUD SP OR BETTER WITH ONE ROW OF 10d NAILS SPACED 6" O.C.
  5. DIAGONAL BRACE TO BE APPROXIMATELY 45 DEGREES TO ROOF DIAPHRAM AT 4'-0" O.C.
  6. CONSTRUCT HORIZONTAL BRACE CONNECTING A 2x6 STUD AND A 2x4 STUD AS SHOWN WITH 16d NAILS SPACED 6" O.C. HORIZONTAL BRACE TO BE LOCATED AT THE MIDSPAN OF THE LONGEST STUD. ATTACH TO VERTICAL STUDS WITH (4) 10d NAILS THROUGH 2x4. (REFER TO SECTION A-A)
  7. GABLE STUD DEFLECTION MEETS OR EXCEEDS L/240.
  8. THIS DETAIL DOES NOT APPLY TO STRUCTURAL GABLES.
  9. DO NOT USE FLAT BOTTOM CHORD GABLES NEXT TO SCISSOR TYPE TRUSSES.
  10. NAILS DESIGNATED 10d ARE (0.131" X 3") AND NAILS DESIGNATED 16d ARE (0.131" X 3.5")

Minimum Stud Size Species and Grade	Stud Spacing	Without Brace	2x4 L-Brace	DIAGONAL BRACE	2 DIAGONAL BRACES AT 1/3 POINTS
		Maximum Stud Length			
2x4 SP No 3/Stud	12" O.C.	3-11-3	6-8-0	7-2-14	11-9-10
2x4 SP No 3/Stud	16" O.C.	3-6-14	5-9-5	7-1-13	10-8-11
2x4 SP No 3/Stud	24" O.C.	3-1-8	4-8-9	6-2-15	9-4-7

\* Diagonal braces over 6'-3" require a 2x4 T-Brace attached to one edge. Diagonal braces over 12'-6" require 2x4 l-braces attached to both edges. Fasten T and l braces to narrow edge of web with 10d nails 8" o.c., with 3" minimum end distance. Brace must cover 90% of diagonal length.

MAXIMUM WIND SPEED = 146 MPH  
 MAX MEAN ROOF HEIGHT = 30 FEET  
 CATEGORY II BUILDING  
 EXPOSURE B or C  
 ASCE 7-98, ASCE 7-02, ASCE 7-05  
 DURATION OF LOAD INCREASE : 1.60

STUD DESIGN IS BASED ON COMPONENTS AND CLADDING.  
 CONNECTION OF BRACING IS BASED ON MWFRS.