

MiTek USA, Inc.

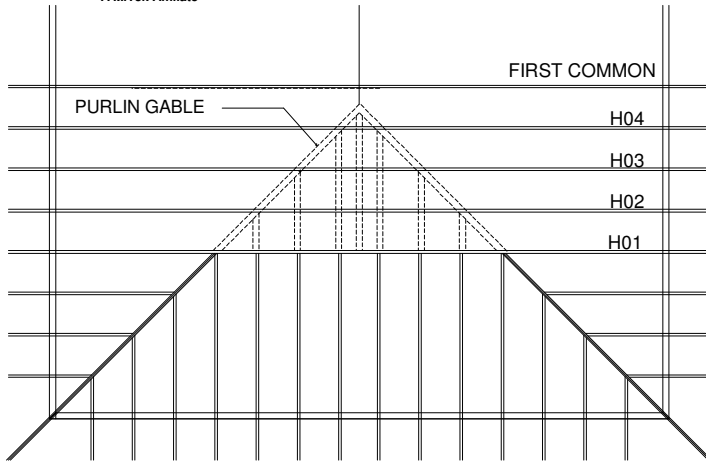

STUD SPACING ON PURLIN GABLE TO BE LESS THAN OR EQUAL TO THE LEAST TOP CHORD PURLIN SPACING ON THE GIRDER OR HIP TRUSS.

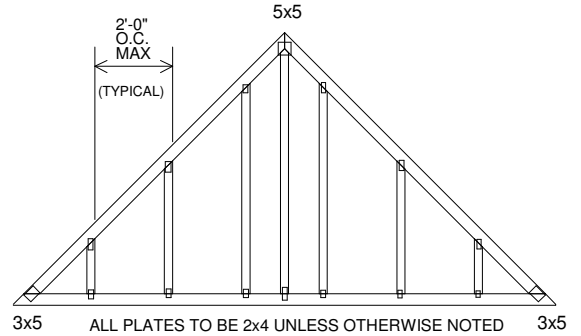

**TYPICAL "PURLIN GABLE"**

REFER TO ENGINEERED TRUSS DRAWING FOR EACH INDIVIDUAL TRUSS

THE PURLIN GABLE TO BE LAID ON TOP OF THE HIP TRUSSES AND ATTACHED WHERE IT HAS CONTACT WITH THE TRUSSES BELOW.

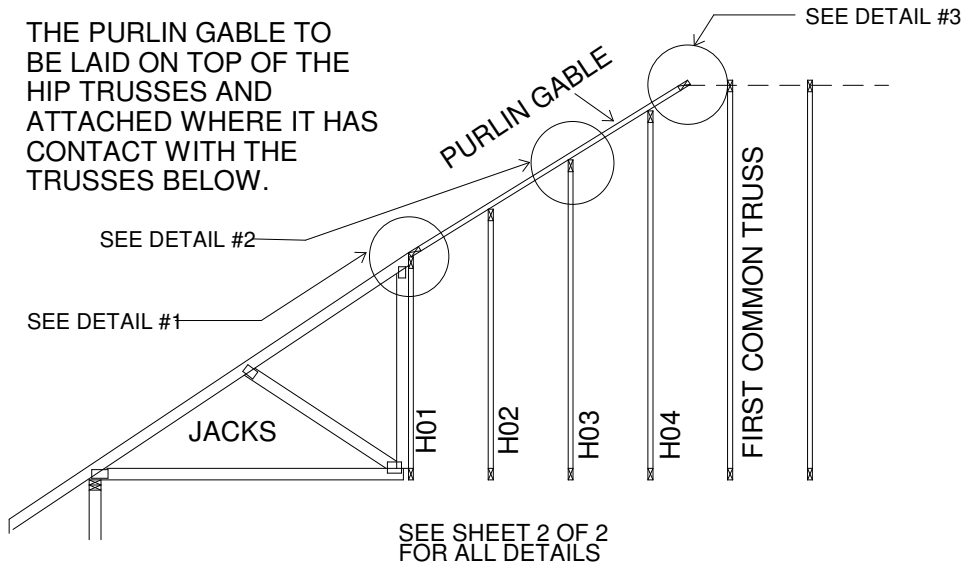

- MAX MEAN ROOF HEIGHT = 30 FEET
- CATEGORY II BUILDING
- EXPOSURE B or C
- ASCE 7-98, ASCE 7-02, ASCE 7-05 100 MPH (MWFRS)
- ASCE 7-10, ASCE 7-16 125 MPH (MWFRS)
- WIND DURATION OF LOAD INCREASE : 1.60
- MAX TRUSS SPACING = 24" O.C.
- MAX STUD SPACING = 24" O.C.
- MINIMUM PITCH 2/12
- MAXIMUM PITCH 12/12