

MiTek®



Finish Roller II™

Copyright © 2019, 2020 MiTek®. All rights reserved.

001127MANUAL-OP REV. A

Patented. See Legal Notice for list of patents.

Manual applies to United States equipment.



CAUTION: MiTek recommends printing this manual in high resolution using color ink. Many of the graphics may be unclear and may create an unsafe condition if this recommendation is not followed.

MiTek[®]

Finish Roller II[™]

MiTek Machinery Division
301 Fountain Lakes Industrial Drive
St. Charles, MO 63301
Phone: 800-523-3380
Fax: 636-328-9218
www.mitek-us.com

Part # and Rev.	001127MANUAL-OP REV. A
Date Printed	13 January 2020
Date Created	22 September 2017
Created By	G. Gaia
Approved By	M. Kanjee
Date Revised	10 January 2020
Revised By	G. Gaia, R. Tucker

Legal Notice

Patents

Made and sold under one or more of the following patents:

U.S. RE37,797	U.S. 5,454,687	U.S. 5,553,375
U.S. 5,468,118	U.S. 6,079,325	U.S. 6,145,684
U.S. 6,330,963	U.S. 6,405,916	U.S. 6,651,306
U.S. 6,807,903	Other patents pending	

Return Goods Policy

Return goods cannot be accepted without prior authorization and are subject to a restocking charge. The Seller certifies the articles specified herein were produced in compliance with all provisions of the Fair Labor Standards Act of 1938, as amended, including Section 12.—Rev. 6/98.

Corrections and Improvements

To report errors or recommend improvements to this manual, please complete the Document Evaluation Form in the appendices. Mail or fax the form to:

MiTek Machinery Division
301 Fountain Lakes Industrial Drive
St. Charles, MO 63301
Attn: Engineering Manager, Fax: 636-328-9218

Table of Contents

Safety (English)	1
Safety Indicator Signal Words	1
General Equipment Safety Rules	2
E-Stop Locations	4
Lockout/Tagout	5
Lockout/Tagout Guidelines	5
Electrical Lockout/Tagout Procedures	6
Troubleshooting with an Energized Machine	9
Safety Tests	10
Inspecting the Press	10
Checking the Function of the E-Stop Pushbuttons	10
Checking the Function of the Pull-Cords	12
Checking the Function of the Light Curtain System	14
Restricted Zone	15
Marking the Restricted Zone	16
Safety Symbol Definitions	17
Declaration of Safety Conformity	22
Indicadores de seguridad: Palabras de aviso	23
Seguridad (Español)	23
Reglas de seguridad para el equipo de general	24
Ubicaciones de los paros de emergencia	27
Bloqueo/Etiquetado	28
Pautas de bloqueo/etiquetado	28
Procedimientos de bloqueo/etiquetado eléctricos	29
Solución de problemas con una máquina energizada	32
Pruebas de seguridad	33
Inspección de la prensa	33
Verificación del funcionamiento de los pulsadores de paro de emergencia	33
Verificación del funcionamiento de las cuerdas de parada de emergencia	35
Verificación del funcionamiento del sistema de cortina óptica	37
Zona Restringida	39
Señalización de la zona restringida	41
Definiciones de los símbolos de seguridad	41
Declaración de conformidad de seguridad	46
Introduction	47
Introduction to the Manual	47
Purpose and Scope of This Manual	47
Understanding the Manual	48
Additional Resources	49
Website	49
Phone or E-mail Support	49
General Information	50
Introduction to the Equipment	50
Purpose of the Equipment	50
Safety Compliance of the Equipment	50
Description of the Equipment	50
Identifying Your Machine	52
Main Components and Optional Components	52

Technical Specifications	53
Installation	54
Installation Requirements	54
Environmental Requirements	54
Infrastructure Requirements	55
Installing the Press	56
Gathering Tools	56
Choosing a Location for the Press	56
Lifting and Moving the Press	57
Verifying Components and Hardware	58
Removing the Pull-Cord Support	60
Checking and Adjusting the Height of the Press	61
Leveling the Press	62
Installing the Lumber Guides	62
Installing Pull-Cord Switches	64
Installing the Pull-Cord Switch Stands	65
Installing the Pull-Cords	67
Tensioning the Pull-Cords	68
Connecting Cables to the Pull-Cord Switches	68
Connecting Power to the Press	69
Checking Motor Rotation	69
Performing the Safety Test	69
Aligning the Photoelectric Sensor	69
Aligning the Light Curtain for End-Eject Systems	69
Verifying All Rollers are at Correct Height	70
Marking Restricted Zone	71
Marking Area on Your Own	71
Installing MiTek Restricted Zone Tape	71
Operation	72
Before You Begin	72
Safety Operating Notes	72
Stopping the Press	73
Indicators on the Press	76
Indicators on Optional Light Curtains	77
Operating the Press	78
Operating the Press	78
Operating the Press in Manual Mode	79
Operating the Press in Automatic Mode	80
Maintenance	81
Introduction to Maintaining Your Press	82
Preventive Maintenance & Parts	82
Performing Maintenance Safely	83
Before Operating This Machine	83
Lockout/Tagout	84
Important Safety Information	84
Making Adjustments and Replacing Parts	86
Wearing Personal Protective Equipment	87
Testing the Safety of the Machine	87
Cleaning the Press	87
Maintaining the Mechanical System	88
Gearmotor	88
Chains and Sprockets	93

Bearings and Rollers	100
Electrical System	106
Electrical Enclosure	106
Photoelectric Sensor	106
Pull-Cord	108
Light Curtain	110
VFD (Variable Frequency Drive)	114
Safety Controller	114
Troubleshooting	115
Using the Troubleshooting Appendix	115
Safety Notes for Troubleshooting	115
General Troubleshooting Safety Tips	115
Electrical Troubleshooting Safety Tips	116
Getting Started with Troubleshooting	117
Tools Required	117
First Steps	118
Identifying Problems and Solutions	119
Diagnostics	122
Safety Controller Diagnostics	122
Light Curtain Diagnostics	123
Parts List	124
Using the Parts List Appendix	124
Safety Notes for Replacement Parts	124
Part Numbers	125
Guard Part Numbers	127
Maintenance Checklist	129
Using the Maintenance Checklists	129
Safety Notes for the Maintenance Checklists	129
Daily Checklist	130
Weekly Checklist	131
Monthly Checklist	132
Drawing Set	133
Document Evaluation	134
Document Evaluation Form	135
General Evaluation	135
Specific Evaluation	135
Glossary	136
Index	140

Safety (English)

Purpose of Chapter

This chapter explains general information and specific procedures for operating the machine safety.

Safety Indicator Signal Words

The following signal words and colors are used throughout this document to indicate safety hazards. Pay careful attention when you see them. The level of severity differs for each signal word and color.

Signal words are accompanied by graphics showing what personnel should or should not do. The graphics are called safety symbols and are defined on page 17, but more specific text is provided every time a graphic is used throughout the manual. Everyone near the machine must be trained on how to read these safety indicators.

Failure to comply with the instructions accompanying each signal word may result in property damage, personal injury, or even death. Personnel must follow all safety procedures and practices to ensure the safest possible operation of this equipment. However, at no time is this document a substitute for common sense. Personnel must ensure that the work environment is safe and free of distractions.



Refiérase a la página 1 para español.

For safety information in Spanish, refer to page 1.

Danger	Indicates an imminently hazardous situation which, if not avoided, is likely to result in death or serious injury.
Warning	Indicates a potentially hazardous situation, which, if not avoided, may result in death or serious injury.
Caution	Indicates a potentially hazardous situation which, if not avoided, may result in minor or moderate injury.
Notice	Calls attention to information that is significant to understanding the operation at hand or the potential for property damage.
Environmental	Applies to conditions that may affect the environment but do not have an immediate, direct effect on personnel or equipment.

General Equipment Safety Rules

Because it is impossible to anticipate every circumstance that might involve a hazard, the safety information provided in this equipment manual and on the machine is not all-inclusive. If this machine is operated or serviced using a procedure not specifically recommended by the manufacturer, the procedure shall be approved by a professional engineer to ensure it will not render the equipment unsafe. Use extreme caution and common sense at all times.

Know Your Equipment

- Read this manual completely before using or maintaining the equipment. Do not operate this machine unless you have a thorough knowledge of the controls, safety devices, emergency stops, and operating procedures outlined in this manual.
- Read and follow all safety notes. Failure to comply with these instructions may result in economic loss, property damage, and/or personal injury including death.
- Refer to the lockout/tagout guidelines on the following pages to safely perform maintenance and troubleshooting of this equipment.
- Observe and obey all safety labels. Replace worn labels immediately.
- Use this equipment solely for the purpose described in this manual.
- Only qualified personnel should attempt to operate or perform maintenance on this equipment. “Qualified personnel” is defined as:

...a person or persons who, by possession of a recognized degree or certificate of professional training, or who, by extensive knowledge, training, or experience, has successfully demonstrated the ability to solve problems relating to the subject matter and work—ANSI B30.2-1983

...one who has skills and knowledge related to the construction and operation of the electrical equipment and installations and has received safety training on the hazards involved—NEC 2002 Handbook

Personal Safety

- Always wear safety glasses and hearing protection in an industrial environment.
- Utilize a filtering face piece (dust mask) when working near sawdust.
- Wear proper clothing and appropriate personal protective equipment (e.g., safety glasses and hearing protection.) Do not wear loose clothing or jewelry. Confine long hair by tying it back.
- Use caution when lifting heavy parts or material.

Installing the Equipment

- Follow installation instructions completely.
- Use proper lifting equipment rated for the proper weight.
- This equipment is not for use in a residential area.

Keeping a Safe Environment

- Keep children away. All visitors should be kept a safe distance from the work area. Hazards may not be apparent to individuals unfamiliar with the machine.
- Keep work areas well lit.
- Keep the work area clean and free of any trip or slip hazards.
- Do not use the equipment in damp or wet locations, or expose it to rain or snow.
- Minimize dust clouds and protect your equipment by cleaning dust in this manner:
 - a) Shut down electrical power and sources of ignition.

	NOTICE
	<p>Never use compressed air inside an electrical enclosure. It may force contaminants into electrical connections.</p> <p>Use a vacuum to remove dust from electrical enclosures. Canned air is acceptable after vacuuming.</p>

- b) Vacuum dust prior to blowing with air.
- c) Powered cleaning equipment such as vacuums must be consistent with local governmental codes for use in dusty conditions.

Operating and Maintaining the Equipment

- Ensure that all people, tools, and foreign objects are clear of the restricted zones before operating this equipment. The restricted zones are shown on page 15.
- Perform safety tests to ensure all E-stops are working properly before operating the equipment at the initial startup, after performing any maintenance, and in accordance with the maintenance schedule.
- In case of machine malfunction, stop the machine immediately using an E-stop, lockout/tagout, and report the malfunction to a supervisor.
- Do not leave the machine until all parts have come to a complete stop and all electrical power has been shut off.
- Check for worn or damaged parts regularly. Repair or replace them immediately.
- Keep the mechanical and electrical systems in good working order at all times. Repair leaks and loose connections immediately. Never exceed the recommended electrical power.

- Check that all guards and safety devices are in place and in working order before each shift starts. All protective guards and safety devices must be in place before and during use of the machine. Never disconnect or bypass any safety device or electrical interlock.
- Only qualified maintenance personnel shall remove, repair, or install safety devices.
- Periodically inspect the quality of the finished product.

Electrical Safety Notes

- Do not use any liquids in the interior of electrical cabinets.
- When using solvents on and around the machine, remove power to the machine to eliminate the chance of sparking, resulting in explosion or fire. Wear a respirator approved for use with solvents.

E-Stop Locations

The E-stop pushbuttons and the pull-cords stop the press immediately in an emergency. See Figure SAFETY-1 for E-stop and pull-cord locations.



Figure SAFETY-1: E-Stop and Pull-Cord Locations

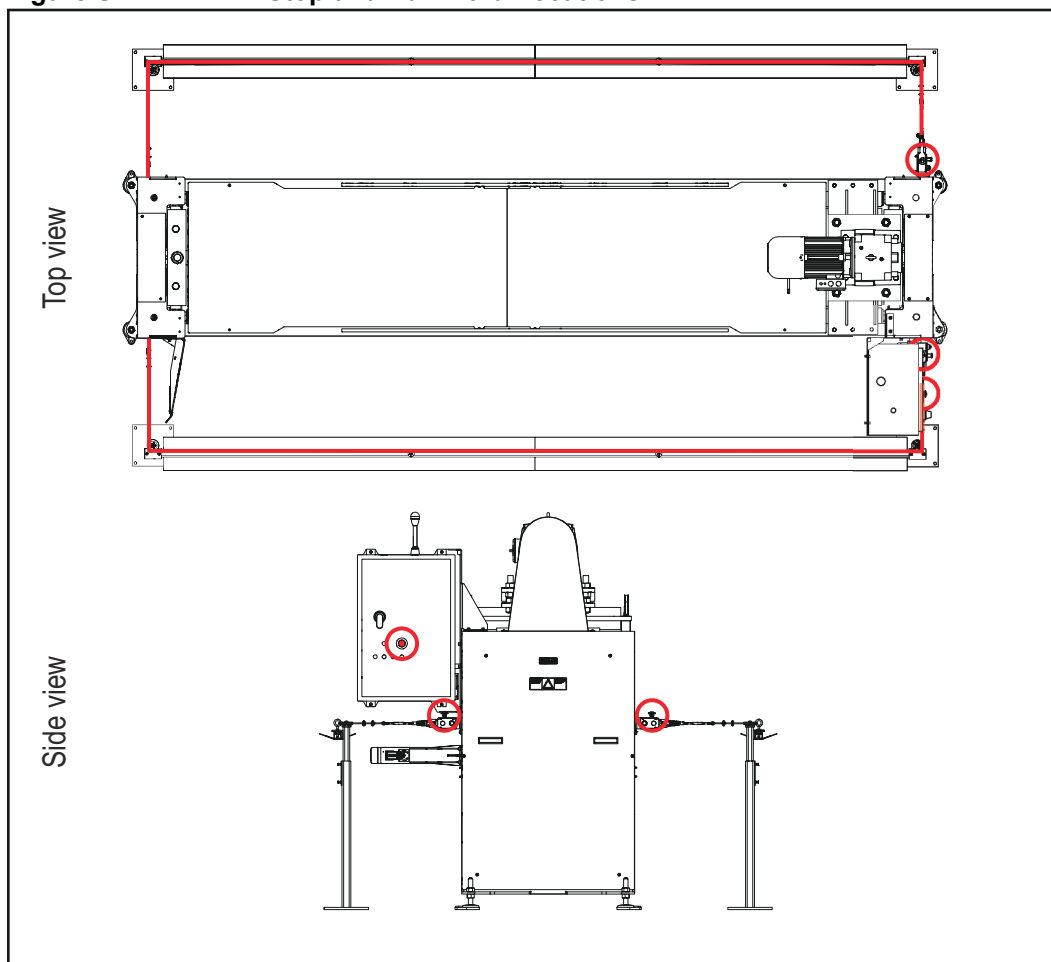

See page 73 for additional information about E-stops.

Lockout/Tagout

Lockout/Tagout Guidelines

Lockout/tagout all energized systems before performing maintenance on them.

All lockout/tagout guidelines must be met according to OSHA 29 CFR 1910.147. A specific procedure should be included in your company's energy control program. This manual is not intended to replace your company's de-energizing or lockout/tagout procedure required by OSHA, but merely to provide general guidance.

The term "lockout," as used in this manual, means placing a lockout device, such as a keyed padlock, on any and all energy sources to ensure that the energy isolating device and the equipment being controlled cannot be re-energized or operated until the lockout device is removed. The graphic on page 7 shows where the electrical disconnects are located for this machine.

- Energy sources include electrical, mechanical, hydraulic, pneumatic, chemical, thermal, or other energy.
- In the case of electrical energy sources, the main power and control power to the machinery must be turned off and physically locked in the Off position.

If more than one person is working in a restricted zone, use a group lockout device that will allow each person to use a lock that can be removed only by the person performing the maintenance.

"Tagout" means that a prominent warning is securely fastened to an energy-isolating device to indicate that the equipment shall not be operated.

Whenever you see the blue lock symbol (see margin), lockout/tagout!

Figure SAFETY-2: Sample Lockout/tagout Device



Electrical Lockout/Tagout Procedures

Working on a Machine Outside the Machine's Main Electrical Enclosure



If you are working on the electrical transmission line to the machine, follow the procedure on page 8.

Before performing maintenance on any machine with electrical power, lockout/tagout the machine properly. When working on a machine outside of the machine's main electrical enclosure, not including work on the electrical transmission line to the machine, follow your company's approved lockout/tagout procedures which should include, but are not limited to the steps here.

1. Engage an E-stop on the machine.
2. Turn the disconnect switch handle to the Off position. See Figure SAFETY-3.



	 WARNING
	ELECTROCUTION HAZARD. When the disconnect switch is off, there is still live power within the disconnect switch's enclosure. Always turn off the power at the building's power source to the equipment before opening this electrical enclosure.

Figure SAFETY-3: Turning the Disconnect Switch to the Off Position



3. Attach a lock and tag that meet OSHA requirements for lockout/tagout.
4. Restrain or de-energize any remaining part that could have live or stored power.

Figure SAFETY-4: Sample of a Lockout/Tagout Mechanism on an Electrical Enclosure

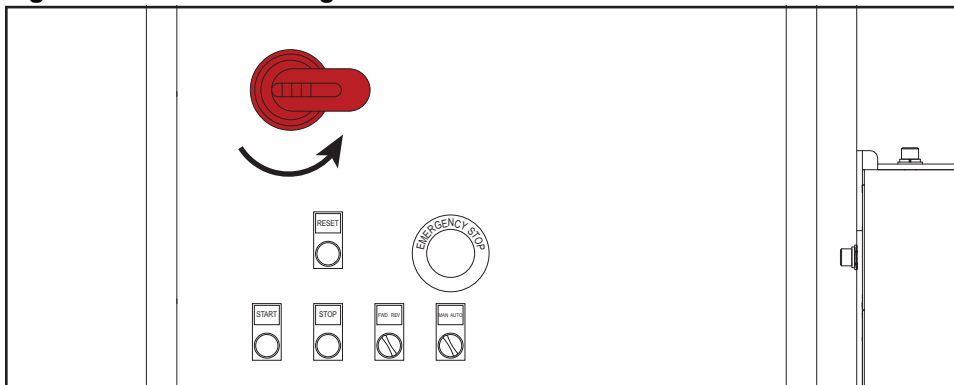

Working on a Machine Inside the Machine's Main Electrical Enclosure or in the Electrical Transmission Line to the Machine

Before opening the main electrical enclosure, or attempting to repair or replace an electrical transmission line to the machine, lockout/tagout the machine properly. Follow your company's approved lockout/tagout procedures which should include, but are not limited to the steps here.

1. Engage an E-stop on the machine.
2. Shut the power to the machine off at the machine's power source which is usually an electrical service entry panel on the facility wall. One example of a locked-out power source panel is shown in page 8.
3. Attach a lock and tag that meets OSHA requirements for lockout/tagout.
4. Open the door to the enclosure in which you need access, and using a multimeter, verify that the power is off.

Figure SAFETY-5: Sample of a Lockout/Tagout Mechanism on a Power Source Panel





Troubleshooting with an Energized Machine

Only a qualified electrician, using the personal protective equipment and following the procedures recommended in NFPA 70E should ever attempt service or repair of or near an energized area or component of the machine.

Whenever maintenance is performed while the equipment is electrically energized, there is a potential electric arc flash hazard. Refer to NFPA 70E for the personal protective equipment required when working with electrically energized components. Physically restrain any components capable of movement when working on or near those components.

Safety Tests



This test procedure **MUST** be performed by qualified personnel at startup and after ANY maintenance, adjustment, or modification. Testing ensures that the safety system and machine control system work together to stop the machine properly.

	 DANGER
	<p>If the Finish Roller II fails any part of the safety test, immediately lockout/tagout and call Machinery Division Customer Service to fix the problem.</p> <p>Operating a press that has failed any part of the safety test may result in serious physical injury or death.</p>

Inspecting the Press

Conduct a visual inspection of the infeed and outfeed of the press to verify that there aren't obstructions on the conveyors or in the press itself. Check the press and its guards to verify that they are not damaged.

Checking the Function of the E-Stop Pushbuttons

	 DANGER
	<p>Make sure that no other personnel are in the restricted zone, shown on pages 15 and 16, before starting this portion of the safety test.</p> <p>Operating the press with personnel in the restricted zone during the safety test may result in severe physical injury or death.</p>

1. Turn the disconnect switch on the main electrical enclosure to the On position.

Figure SAFETY-6: Turning the Disconnect Switch to the On Position

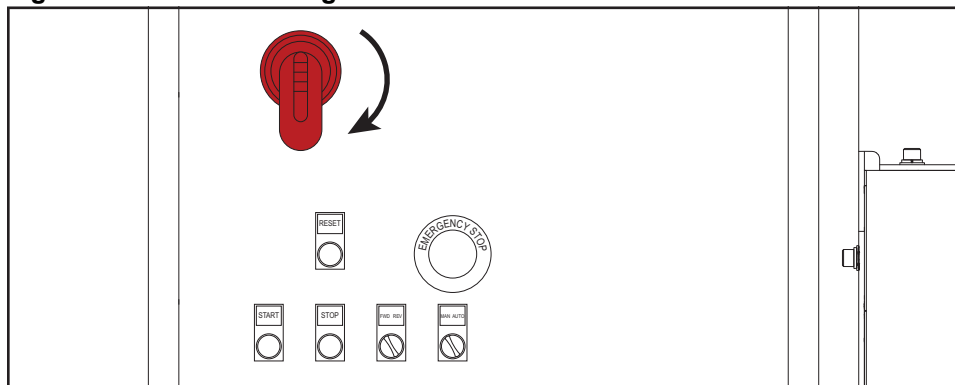

- Press and hold the Reset button for one second to reset the safety circuit and prepare the press to run.

Figure SAFETY-7: Pressing Reset Button

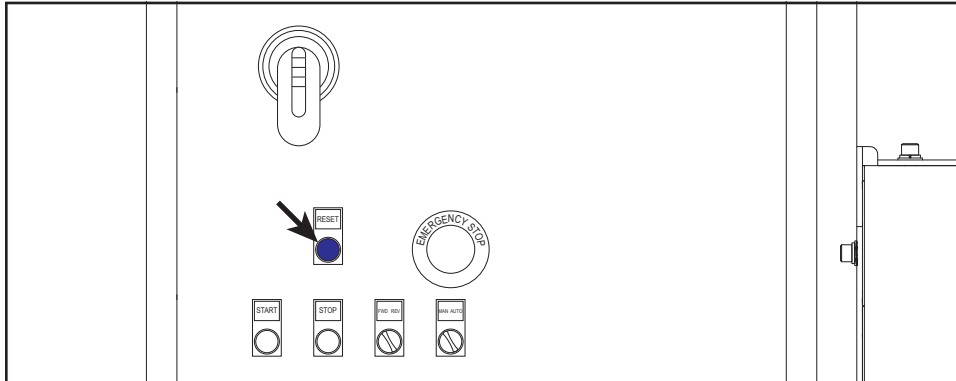

- Press Start.

Figure SAFETY-8: Starting the Press

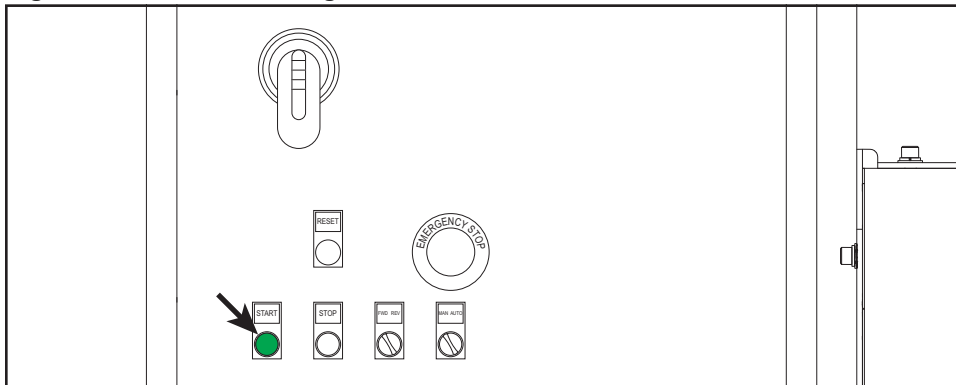

- While the press is running, press the E-stop pushbutton on the main electrical enclosure. Verify the following:
 - the press rollers should stop turning immediately;
 - the beacon on the main electrical enclosure should turn red; and
 - the indicator light on or near the pushbutton should turn red.
- Release the actuated pushbutton by pulling it.
- Repeat steps 2 through 4 with the E-stop pushbuttons on the pull-cord switches and the E-stop pushbuttons on any interlocked machines (if equipped).

NOTICE	
	<p>The E-stop pushbutton should only be used to stop the press in an emergency. For stopping in non-emergencies, use the manual controls.</p> <p>Using the E-stop pushbutton regularly to stop the press may result in excessive wear.</p>

Checking the Function of the Pull-Cords

1. Verify that the pull-cord is tensioned properly. Locate the clear plastic window on the switch, shown in Figure SAFETY-9. The green triangles should be in the center of the window, as shown in position A in Figure SAFETY-9. If the pull-cord is not tensioned properly, see page 109 to tension it.

Figure SAFETY-9: Pull-Cord Switch Window

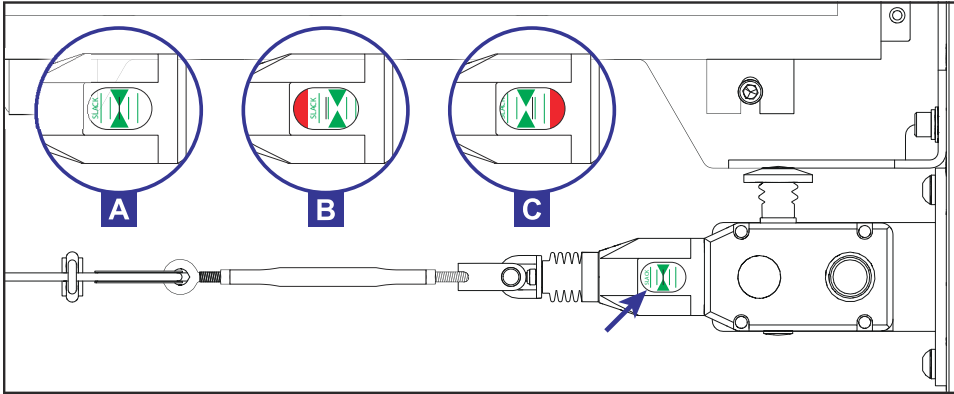
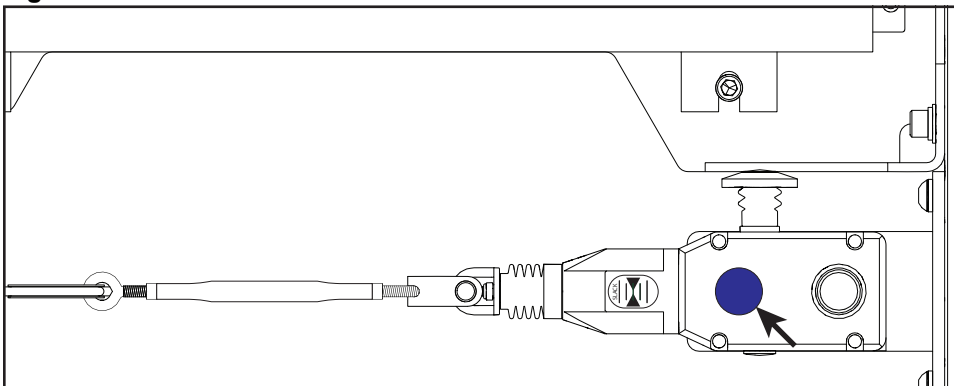

Table SAFETY-1: Pull-Cord Tension

Position	Tensioning
A	Pull-cord is tensioned correctly
B	Pull-cord has too much slack
C	Pull-cord is too tight

2. Press and hold the Reset button on the main electrical enclosure for one second. Press **Start**.
3. While the press runs, pull the pull-cord. When the pull-cord moves 3" to 4" from its resting position, verify that the following happens:
 - the press rollers should stop turning immediately;
 - the beacon on the main electrical enclosure should turn red; and
 - the light on the pull-cord switch should blink red.
4. Press the blue reset button on the switch that you tripped.

Figure SAFETY-10: Pull-Cord Switch Reset Button



5. Repeat steps 2 through 4 with the pull-cord on the opposite side of the press.
6. Continue based on the configuration of your system.
 - If you have a side-eject system, you do not have a light curtain to test. Begin operation.
 - If you have an end-eject system, you have a light curtain. Figure SAFETY-11 shows an example of a system with a light curtain. Continue with Checking the Function of the Light Curtain System below.

Figure SAFETY-11: Example of a Light Curtain System

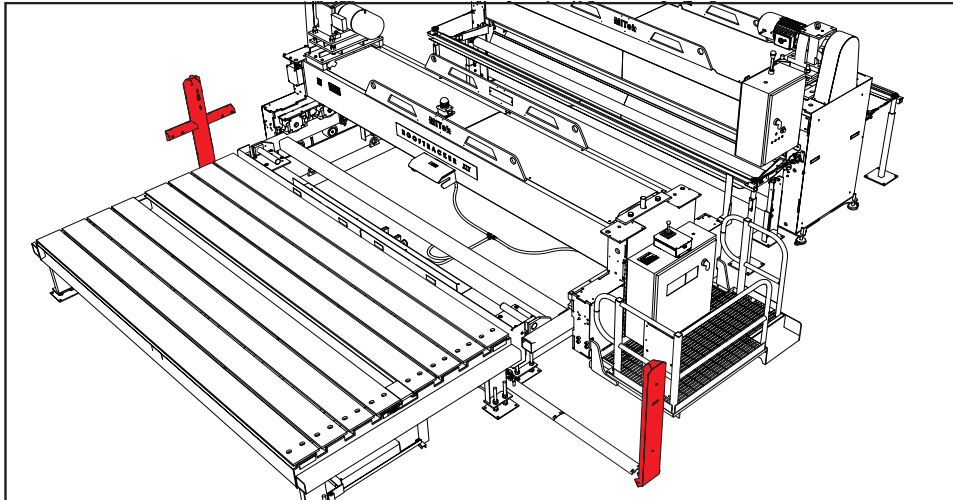

Checking the Function of the Light Curtain System

Light curtains are used with end-eject systems only.

Checking the Function of the Muting Sensors

The light curtain uses muting sensors to detect a gantry head passing through without triggering an E-stop. Check the muting sensors by using the following steps:

1. Press and hold the **Reset** button on the main electrical enclosure of the *Finish Roller II* press for one second. Press **Start**.
2. While the *Finish Roller II* press is running, move the gantry head through the light curtain onto the gantry lifter. Verify that the *Finish Roller II* press is still running.
3. Lockout/tagout on the gantry head's main electrical enclosure to prevent the gantry head from moving during the rest of the test.



Checking the Function of the Light Curtain

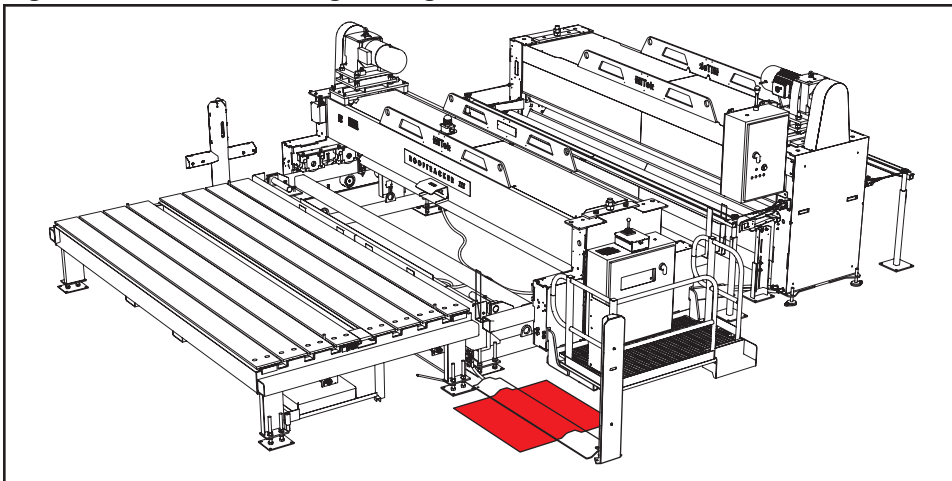

1. While the *Finish Roller II* press runs, walk between the transmitter and receiver of the light curtain to block the light curtain. The approximate area where you should walk is shown in red in Figure SAFETY-12. Verify that the following happens:
 - the press rollers should stop turning immediately;
 - the beacon on the main electrical enclosure should turn red; and
 - the beacon on the transmitter stand of the light curtain should flash red.

Figure SAFETY-12: Testing the Light Curtain



2. Walk to the main electrical enclosure on the press. Attempt to start the press. The press should not start.
3. Press and hold **Reset** on the main electrical enclosure for one second.
4. Remove the lock and tag from the gantry head.
5. Begin operation.

Restricted Zone

	 DANGER
	<p>Stay out of the restricted zone when equipment is in use. Serious injury or death may result if personnel are in the restricted zone.</p> <p>Always look for personnel in the restricted zone before operating equipment.</p>

The restricted zone varies slightly by plant layout. The following are examples of restricted zones.

Figure SAFETY-13: Sample Restricted Zone for Side-Eject Systems

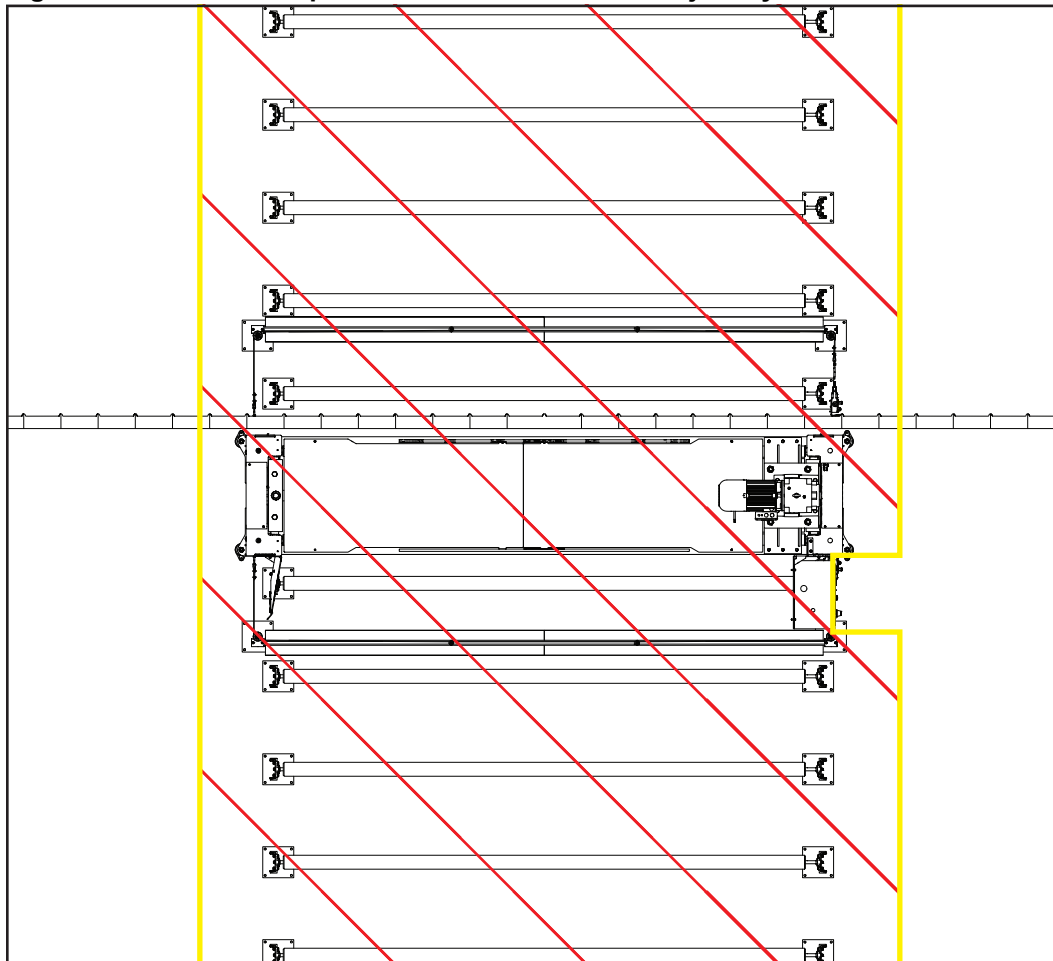
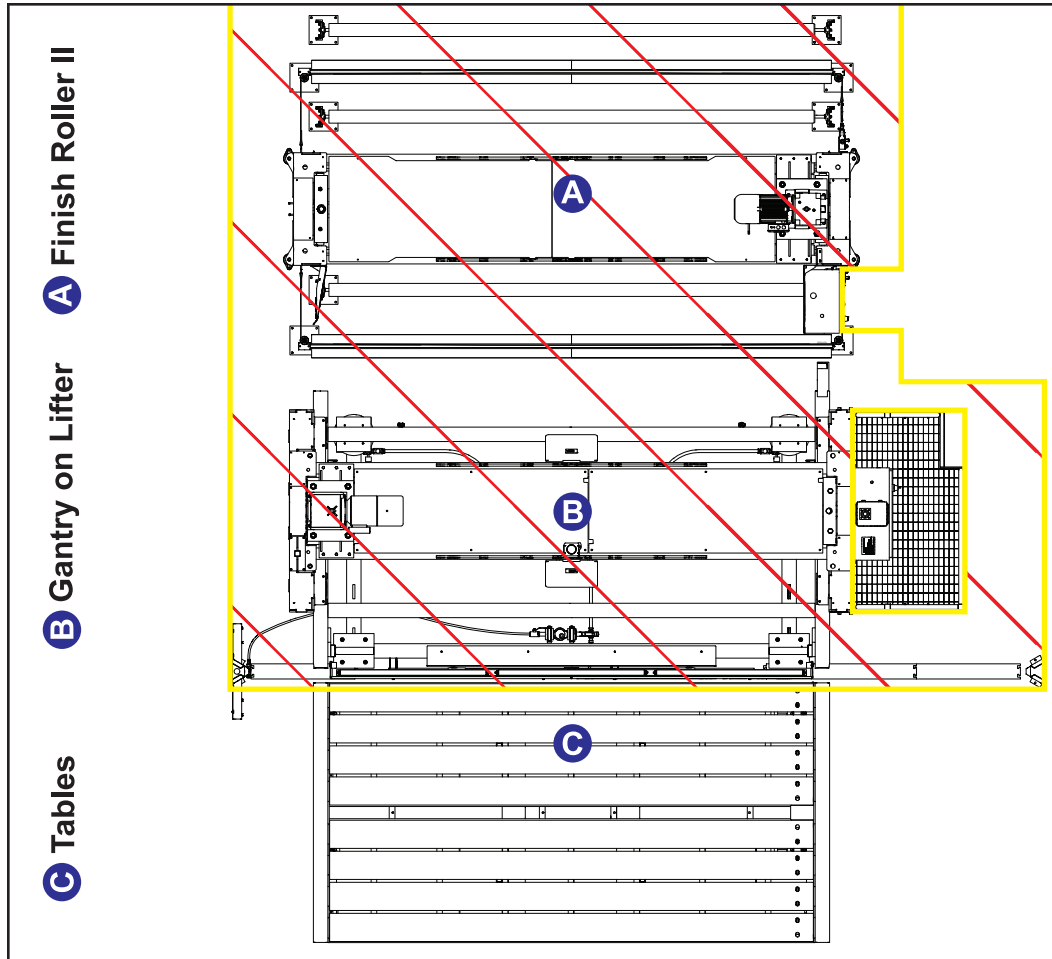

Figure SAFETY-14: Sample Restricted Zone for End-Eject System



Marking the Restricted Zone

The restricted zone must be marked so everyone near the equipment can clearly see the area where danger may exist.

Safety Symbol Definitions

The safety symbols shown in this section are found throughout the manual to indicate hazards related to this machine. All personnel expected to operate or maintain this machine should be familiar with these safety symbols and their meanings.



User caution. It indicates a condition where equipment damage resulting in injury could occur if operational procedures are not followed. To reduce risk of damage or injury, refer to accompanying documents, and follow all steps or procedures as instructed.



Electrical hazard. It indicates dangerous high voltages inside of an enclosure and/or the presence of a power source. To reduce the risk of fire or electric shock, do not attempt to open the enclosure or gain access to areas where you are not instructed to do so. Refer servicing to qualified service personnel only.

This equipment should be operated only from the type of source indicated on the manufacturer's identification label. Installation should be in compliance with applicable sections of the national electric code. Consult your local building code before installing.



Crush hazard. Keep hands clear.



Noise hazard. Equipment produces loud noise in excess of 100 DBA during operation. Use appropriate PPE to protect hearing when in the vicinity of this equipment.



Trip hazard. Pay attention when walking in this area.



Kickback hazard.



Keep hands clear of cutting parts.



Keep hands and body clear.



Operation of this equipment may result in flying debris and excessive noise. To reduce the risk of eye injury, wear only approved PPE.



Keep feet away from moving parts.



Keep hands away from moving parts.



Use sling equipment rated for at least ___ lbs / ___ kgs when lifting this equipment.



Equipment has automatic restarting capability. Lockout/tagout on the upstream disconnect before servicing.



The operation of this equipment requires the use of PPE.
Do not operate without wearing the required protective clothing.



Refer to manual. After installation, read the user's guide carefully before operating. Follow all operating and other instructions carefully.



Circuits are live. Lockout/tagout on the upstream disconnect prior to servicing.



Lockout in a de-energized state.



Lift point. In order to decrease the likelihood of damage to the equipment, use only the lift points indicated in the manual.



Read all safety warnings and instructions before proceeding.



Unplug equipment before servicing.



Hazardous moving parts are located behind this access panel. Do not operate this equipment without all guards and covers in place.



Do not place containers with liquids such as coffee, water, soda, etc. on this equipment.

Do not operate this equipment in a wet environment.



Do not expose to water.



No lift point. Do not lift this device with a hook/crane assembly. Equipment damage occurs. Refer to the installation instructions.



Do not step or stand upon this equipment. Stepping or standing on this equipment may result in serious injury.



Not a step. Do not step or stand at this location.



Do not use unapproved lubricants in this equipment.



Do not operate without guards in place.



Do not weld.



Do not discard into the municipal waste stream.

Declaration of Safety Conformity

Conforms electrically to the following:

- NFPA 79
- NEC Electrical Code
- Electrical enclosures carry UL 508A and the CUL for Canada
- Safety circuit conforms to Category 4 redundant monitoring

Conforms mechanically to the following:

- 10CFR 1910
- ANSI B 11.19

Seguridad (Español)

**Objetivo
del Capítulo**

Este capítulo explica la información general y los procedimientos específicos para operar la máquina de manera segura.

Indicadores de seguridad: Palabras de aviso

Las siguientes palabras y colores de aviso se utilizan a lo largo de este documento para indicar riesgos de seguridad. Preste suma atención cuando los vea. El nivel de gravedad es diferente por cada palabra o color de aviso.

Las palabras de aviso van acompañadas por gráficos que muestran al personal lo que deben y no deben hacer. Los gráficos se llaman símbolos de seguridad y se definen en la página 39, pero se proporciona un texto más específico cada vez que se utiliza un gráfico por todo el manual. Todas las personas que estén cerca de una máquina tienen que ser capacitadas en cómo leer estos indicadores de seguridad.

No cumplir las instrucciones que acompañan cada palabra de aviso puede producir daños a la propiedad, lesiones personales e incluso la muerte. El personal debe seguir todos los procedimientos y prácticas de seguridad establecidos para asegurar el uso más seguro posible de este equipo. No obstante, en ningún caso este documento reemplaza el sentido común. El personal debe asegurarse de que el entorno de trabajo sea seguro y esté libre de distracciones.

Peligro	Indica una situación de peligro inminente que, si no se evita, ocasionará la muerte o graves lesiones.
Advertencia	Indica una situación potencialmente peligrosa que, si no se evita, podría producir la muerte o lesiones graves.
Precaución	Indica una situación potencialmente peligrosa que, si no se evita, puede producir lesiones menores o moderadas.
Aviso	Llama la atención a información importante para entender la operación que se desea realizar o daños a la propiedad probables.
Ambiental	Se aplica a condiciones que pueden afectar el entorno pero que no tienen un efecto inmediato o directo sobre el personal o el equipo.

Reglas de seguridad para el equipo de general

Debido a la imposibilidad de anticipar todas las circunstancias que podrían constituir un riesgo, la información de seguridad suministrada en este manual del equipo y sobre la máquina no es exhaustiva. Si se utiliza o realiza el mantenimiento de esta máquina utilizando un procedimiento no recomendado específicamente por el fabricante, el procedimiento deberá ser aprobado por un ingeniero profesional para asegurarse de que no afecte la seguridad del equipo. ¡Manéjese siempre con suma precaución y sentido común!



Conozca su equipo

- Lea este manual en su totalidad antes de utilizar o mantener el equipo. No utilice esta máquina a menos que esté perfectamente familiarizado con los controles, los dispositivos de seguridad, los frenos de emergencia y los procedimientos operativos que se describen en este manual.
- Lea y siga todas las notas de seguridad. El no cumplimiento de estas instrucciones podría producir pérdidas económicas, daños a la propiedad y/o lesiones personales, incluida la muerte.
- Refiérase a las pautas de bloqueo/etiquetado proporcionadas en las siguientes páginas para realizar el mantenimiento y solucionar problemas de este equipo en forma segura.
- Observe y cumpla con todas las etiquetas de seguridad. Cambie las etiquetas gastadas inmediatamente.
- Utilice este equipo únicamente para el propósito que se describe en este manual.
- Sólo personal calificado debe intentar utilizar o realizar el mantenimiento de este equipo. Por "personal calificado" se entiende:

...una persona o personas que, por el hecho de poseer un título o certificado de capacitación profesional reconocido o que, por sus amplios conocimientos o experiencia, han demostrado con éxito estar capacitados para resolver problemas relacionados con el tema y el trabajo en cuestión—ANSI B30.2-1983

...una persona que posee habilidades y conocimientos relacionados con la construcción y uso de equipos e instalaciones eléctricas y que ha recibido capacitación en seguridad sobre los riesgos posibles—NEC 2002 Handbook

Seguridad personal

- Use siempre lentes de seguridad y protección auditiva en un entorno industrial.
- Utilice una máscara protectora cuando trabaje cerca de aserrín.
- Utilice ropa adecuada y equipo de protección personal apropiado (por ejemplo, lentes de seguridad y protección auditiva.) No use ropa suelta ni joyas. Si tiene el cabello largo, áteselo para atrás.
- Proceda con precaución cuando levante piezas o materiales pesados.

Instalació del equipo

- Siga las instrucciones de instalación al pie de la letra.
- No utilizar este equipo en zonas residenciales.

Bloqueo/Etiquetado

- Antes de realizar el mantenimiento de los sistemas neumáticos, purgue las líneas para eliminar la presión.
- Bloquee y etiquete todos los sistemas energizados antes de realizar tareas de mantenimiento en ellos. Refiérase a la sección *Pautas de bloqueo/etiquetado* en la página 28.

Cómo mantener un entorno seguro

- Mantenga alejados a los niños. Todos los visitantes deben mantenerse a una distancia segura del área de trabajo. Los riesgos pueden no ser evidentes a las personas no familiarizadas con la máquina.
- Mantenga las áreas de trabajo bien iluminadas.
- Mantenga el área de trabajo limpia y libre de cualquier riesgo de tropiezo o resbalamiento.
- No utilice el equipo en lugares húmedos o mojados y no lo exponga a la lluvia o a la nieve.
- Minimice las nubes de polvo y proteja su equipo quitando el polvo de la siguiente manera:

	AVISO
	<p>¡No utilice nunca aire comprimido dentro de una caja eléctrica! Puede forzar sustancias contaminantes hacia el interior de las conexiones eléctricas.</p> <p>Utilice un aspirador para eliminar polvo de las cajas eléctricas. Es aceptable utilizar aire comprimido después de aspirar.</p>

- aspire el polvo antes de soplarlo con aire
- Apague la alimentación eléctrica y todas las fuentes de ignición
- Si usa aire comprimido, debe ser a compresión baja (no más de 15 psi)
- El equipo eléctrico de limpieza como las aspiradoras debe cumplir con los códigos del gobierno local para uso en condiciones polvorientas.

Uso y mantenimiento del equipo

- Asegúrese de que no haya personas, herramientas y objetos extraños en las zonas restringidas antes de utilizar este equipo. Las zonas restringidas se indican en la página xlvii.
- Realice pruebas de seguridad para verificar que todos los frenos de emergencia funcionen adecuadamente antes de utilizar el equipo al principio de la puesta en marcha y después de realizar cualquier tarea de mantenimiento.
- En caso de que la máquina no funcione correctamente, deténgala inmediatamente utilizando un freno de emergencia e informe el problema a un supervisor.
- No la abandone hasta que todas las piezas se detengan completamente y hasta que se haya apagado la alimentación eléctrica.
- Verifique periódicamente que no haya piezas gastadas o dañadas. Repárelas o cámbielas inmediatamente.
- Mantenga los sistemas neumáticos y eléctricos en buen funcionamiento en todo momento. Repare las fugas y las conexiones sueltas inmediatamente. No exceda nunca la presión ni potencia eléctrica recomendadas.
- Verifique que todos los dispositivos de seguridad estén en buen funcionamiento antes de comenzar cada turno. Todos los dispositivos protectores y de seguridad deben estar en su lugar antes y durante el uso de la máquina. No desconecte ni evite nunca ningún dispositivo de seguridad ni interbloqueo eléctrico.
- Solo el personal de mantenimiento calificado puede quitar o instalar los dispositivos de seguridad.
- Inspeccione periódicamente la calidad del producto terminado.

Seguridad eléctrica

- No utilice líquidos en el interior de los gabinetes eléctricos.
- Cuando utilice disolventes sobre o alrededor de la máquina, desconecte la alimentación para eliminar las probabilidades de chispas, que pueden producir una explosión o incendio. Use un respirador aprobado para el uso con disolventes. Use ropa protectora, guantes y lentes de seguridad.

Ubicaciones de los paros de emergencia

Los pulsadores de paro de emergencia y las cuerdas de parada de emergencia detienen la prensa inmediatamente en caso de emergencia. Vea la Figura SEGURIDAD-1 para conocer las ubicaciones de los paros de emergencia y las cuerdas de parada de emergencia.

Figura SEGURIDAD-1: Los pulsadores de paro de emergencia y las cuerdas de parada de emergencia

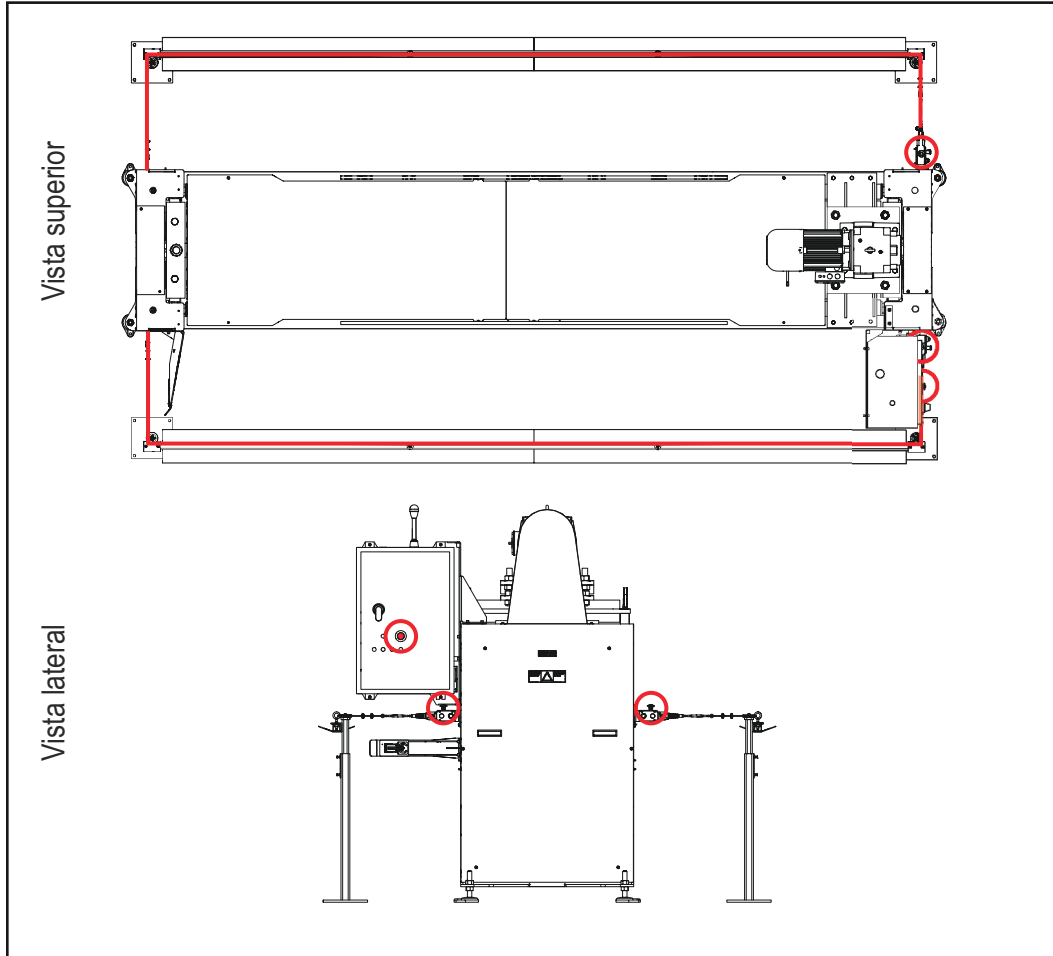

Bloqueo/Etiquetado

Pautas de bloqueo/etiquetado

Deben cumplir con todas las pautas de bloqueo/etiquetado conforme a la norma OSHA 29 CFR 1910.147. El programa de control de energía de la compañía debe incluir un procedimiento específico. El objetivo de este manual no es reemplazar el procedimiento de desenergización o bloqueo/etiquetado requerido por la OSHA, sino proporcionar pautas orientativas generales.

El término "bloqueo", según se utiliza en este manual, se refiere a la colocación de un dispositivo de bloqueo en las fuentes de energía para asegurar que el dispositivo aislador de energía y el equipo controlado por éste no puedan reenergizarse o utilizarse hasta que se retire dicho dispositivo. La foto en la página 30 siguiente muestran los lugares en los que se encuentran los interruptores de desconexión eléctrica de esta máquina.

- Las fuentes de energía incluyen energía eléctrica, mecánica, hidráulica, neumática, química, térmica y otras.
- En el caso de fuentes de energía eléctrica, la alimentación principal y la alimentación de control a la maquinaria deben apagarse y bloquearse físicamente en la posición "off" (apagado).
- Por lo general, como dispositivo de bloqueo se utiliza un candado con llave.

Si hay más de una persona trabajando en una zona restringida, utilice un dispositivo de bloqueo grupal que permita a cada persona utilizar un candado que sólo pueda ser retirado por la persona que realiza el mantenimiento.

Siempre que vea este símbolo, ¡Bloquee/Etiqueta!

Figura SEGURIDAD-2: Ejemplo de un dispositivo de bloqueo/etiquetado



Procedimientos de bloqueo/etiquetado eléctricos

Cuando trabaja en una máquina fuera del gabinete eléctrico principal de la máquina



Si trabaja en la línea de transmisión eléctrica a la máquina, siga el procedimiento de la página 31.

Antes de realizar el mantenimiento de cualquier máquina con alimentación eléctrica, bloquee y etiquete la máquina correctamente. Cuando trabaje en una máquina fuera del gabinete eléctrico principal de la máquina, salvo en el caso de trabajos en la línea de transmisión eléctrica a la máquina, siga los procedimientos de bloqueo y etiquetado aprobados por su empresa, que deberían incluir, entre otros, los pasos aquí indicados.

1. Active un paro de emergencia de la máquina.
2. Gire el mango del interruptor de desconexión a la posición “Off” (Apagado). Vea la Figura SEGURIDAD-3.



 ADVERTENCIA	
	<p>RIESGO DE ELECTROCUCIÓN.</p> <p>Cuando el interruptor de desconexión está apagado, sigue habiendo energía dentro del gabinete del interruptor. Desconecte siempre la alimentación desde la fuente de alimentación del edificio antes de abrir este gabinete eléctrico.</p>

Figura SEGURIDAD-3: Girar el interruptor de desconexión a la posición “Off”



3. Coloque un candado y una etiqueta que cumplan con los requisitos de bloqueo y etiquetado de la OSHA.
4. Trabe o desenergice todos los demás componentes que pudieran estar bajo tensión o tener energía almacenada.

Figura SEGURIDAD-4: Ejemplo de un mecanismo de bloqueo y etiquetado en un gabinete eléctrico

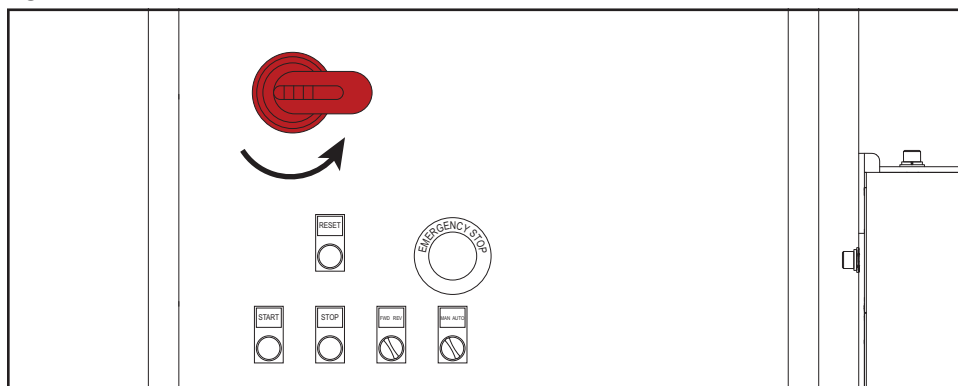

Cuando trabaje en una máquina dentro del gabinete eléctrico principal de la máquina o en la línea de transmisión eléctrica a la máquina

Antes de abrir el gabinete eléctrico principal o intentar reparar o reemplazar una línea de transmisión eléctrica a la máquina, bloquee y etiquete la máquina en forma adecuada. Siga los procedimientos de bloqueo/etiquetado aprobados por la compañía, los cuales deberían incluir, entre otros, los pasos aquí indicados.

1. Coloque un freno de emergencia sobre la máquina.
2. Apague la alimentación a la máquina en la fuente de alimentación, que, por lo general, es un panel de entrada de suministro eléctrico que se encuentra en una pared de las instalaciones. En la Figura SEGURIDAD-5 se muestra un ejemplo de panel de fuente de alimentación bloqueado.
3. Coloque un candado y una etiqueta que cumplan con los requisitos de bloqueo/etiquetado de la OSHA.
4. Abra la puerta del gabinete al que necesita acceder y usando un multímetro verifique que la alimentación esté apagada.

Figura SEGURIDAD-5: Ejemplo de un mecanismo de Bloqueo/ Etiquetado en un panel de entrada de suministro eléctrico





Solución de problemas con una máquina energizada

Sólo un electricista calificado que utilice el equipo de protección personal y siga los procedimientos recomendados en la norma NFPA 70E debe intentar realizar tareas de reparación o mantenimiento en un área o componente energizados de la máquina o en su proximidad.

Cada vez que se realizan tareas de mantenimiento mientras el equipo está eléctricamente energizado, existe un riesgo potencial de formación de un arco eléctrico. Consulte en la norma NFPA 70E el equipo de protección personal requerido para trabajar con componentes eléctricamente energizados. Los componentes neumáticos e hidráulicos pueden moverse de manera imprevista si no se desenergizan. Trabe físicamente cualquier componente que pueda moverse cuando deba trabajar en ellos o en su proximidad.

Pruebas de seguridad



Este procedimiento de prueba DEBE ser realizado por personal calificado al momento de la puesta en marcha y después de CUALQUIER tarea de mantenimiento, ajuste o modificación. Las pruebas garantizan que el sistema de seguridad y el sistema de control de la máquina funcionen conjuntamente a fin de detener la máquina de forma correcta.

	 PELIGRO
	<p>Si el Rodillo de acabado II falla cualquier parte de la prueba de seguridad, bloquee y etiquete inmediatamente y llame al Servicio al cliente de la División de maquinaria para solucionar el problema.</p> <p>Operar una prensa que haya fallado cualquier parte de la prueba de seguridad podría tener como consecuencia lesiones físicas graves o la muerte.</p>

Inspección de la prensa

Realice una inspección visual de la alimentación y la salida de la prensa para verificar que no haya obstrucciones en los transportadores ni en la propia prensa. Revise la prensa y sus protecciones para verificar que no estén dañadas.

Verificación del funcionamiento de los pulsadores de paro de emergencia

	 PELIGRO
	<p>Asegúrese de que ninguna otra persona se encuentre en la zona restringida indicada en las páginas 39 y 40 antes de comenzar con esta parte de la prueba de seguridad.</p> <p>Operar una prensa con personal dentro la zona restringida durante la prueba de seguridad podría causar lesiones físicas graves o la muerte.</p>

1. Gire el interruptor de desconexión en el gabinete eléctrico principal a la posición “On” (Encendido).

Figura SEGURIDAD-6: Girar el interruptor de desconexión a la posición “On

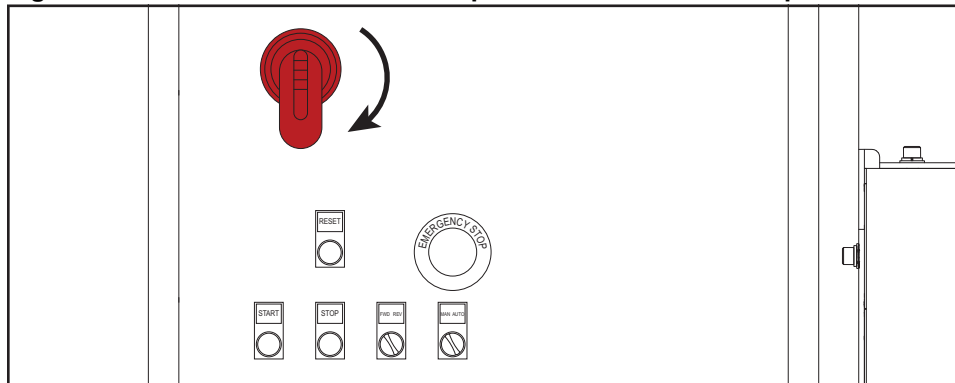

- Mantenga presionado el botón “Reset” (Restablecer) durante un segundo para restablecer el circuito de seguridad y preparar la prensa para el funcionamiento.

Figura SEGURIDAD-7: Presionar el botón “Reset”

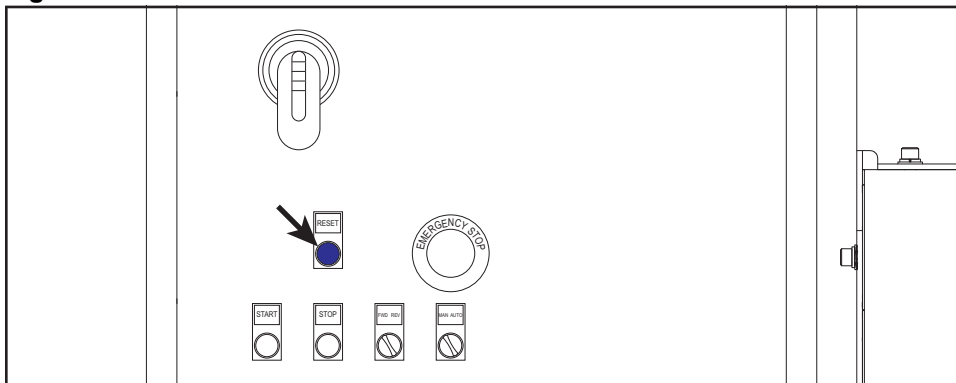

- Presione “Start” (Inicio).

Figura SEGURIDAD-8: Iniciar la prensa

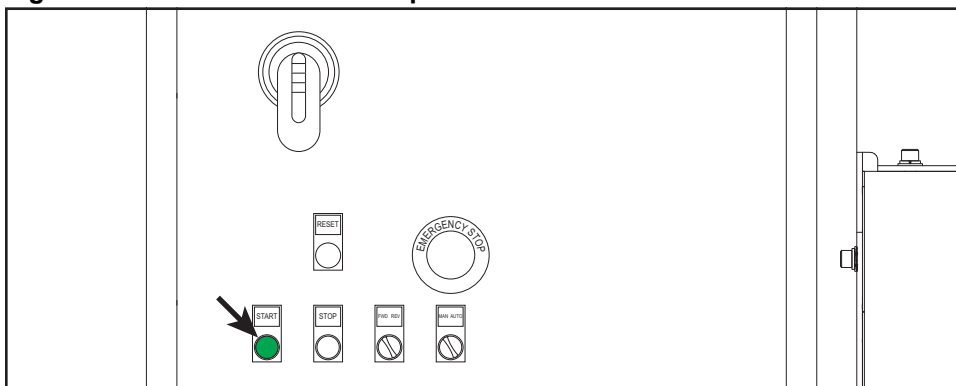

- Mientras la prensa esté en funcionamiento, presione el pulsador de paro de emergencia en el gabinete eléctrico principal. Verifique lo siguiente:
 - los rodillos de la prensa deberían dejar de girar inmediatamente;
 - la luz en el gabinete eléctrico principal debería cambiar a rojo; y
 - la luz indicadora en el pulsador o cerca de este debería cambiar a rojo.
- Suelte el pulsador accionado al jalarlo.
- Repita los pasos 2 a 4 con los pulsadores de paro de emergencia de los interruptores de las cuerdas de parada de emergencia y con los pulsadores de paros de emergencia de cualquier máquina enclavada (si tiene).

AVISO	
	<p>El pulsador de paro de emergencia solo se debe usar para detener la prensa en caso de emergencia. Para detenerla en situaciones que no sean de emergencia, use los controles manuales.</p>
	<p>El uso constante del pulsador de paro de emergencia para detener la prensa puede causar un desgaste excesivo.</p>

Verificación del funcionamiento de las cuerdas de parada de emergencia

1. Verifique que la cuerda de parada de emergencia esté bien tensada. Ubique la ventana de plástico transparente del interruptor, indicada en la Figura SEGURIDAD-9. Los triángulos verdes deberían estar en el centro de la ventana, como se muestra en la posición A de la Figura SEGURIDAD-9. Si la cuerda de parada de emergencia no está bien tensada, vea la página 109 para tensarla.

Figura SEGURIDAD-9: Ventana del interruptor de la cuerda de parada de emergencia



Tabla SEGURIDAD-1: La cuerda de parada de emergencia

Posición	Tensión
A	La cuerda de parada de emergencia está bien tensada
B	La cuerda de parada de emergencia está demasiado holgada
C	La cuerda de parada de emergencia está demasiado tirante

2. Mantenga presionado el botón “Reset” (Restablecer) en el gabinete eléctrico principal durante un segundo. Presione “Start” (Inicio).
3. Mientras la prensa esté en funcionamiento, jale de la cuerda de parada de emergencia. Cuando la cuerda de parada de emergencia se desplace de 3 a 4 pulgadas (7 a 10 cm) desde la posición de reposo, verifique que suceda lo siguiente:
 - los rodillos de la prensa deberían dejar de girar inmediatamente;
 - la luz en el gabinete eléctrico principal debería cambiar a rojo; y
 - la luz del interruptor de la cuerda de parada de emergencia debería parpadear en color rojo.

4. Presione el botón azul de restablecimiento del interruptor que accionó.

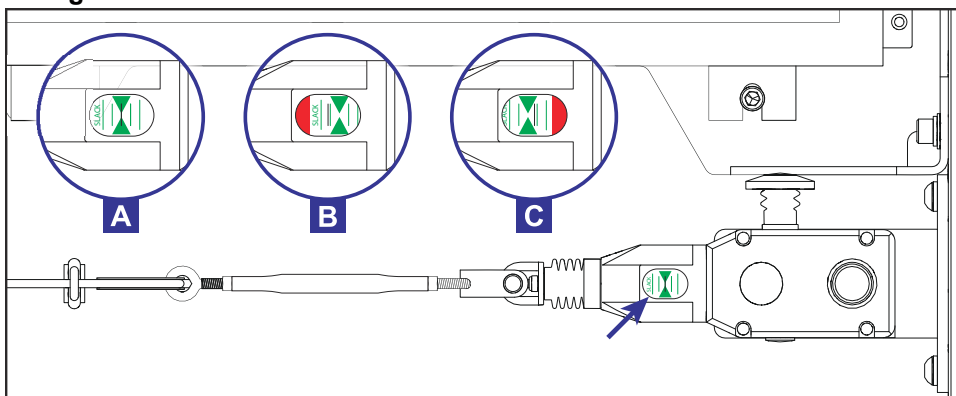
Figura SEGURIDAD-10: Botón de restablecimiento del interruptor de la cuerda de parada de emergencia

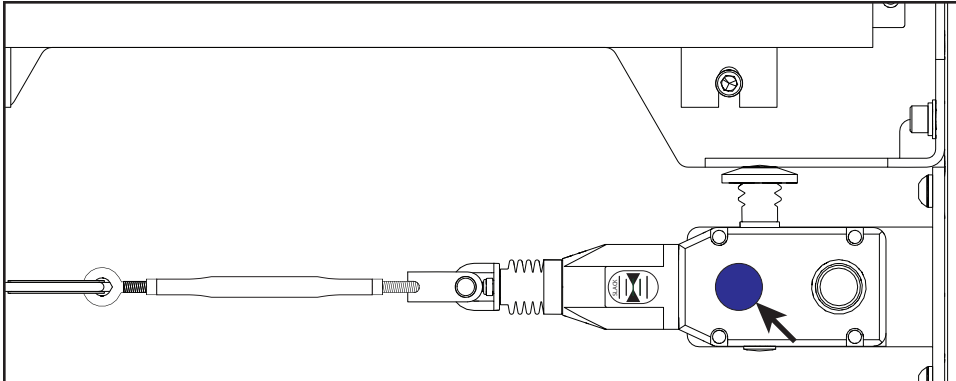

5. Repita los pasos 2 a 4 con la cuerda de parada de emergencia del lado opuesto de la prensa.
6. Continúe de acuerdo con la configuración de su sistema.
 - Si tiene un sistema de eyección lateral, no tiene una cortina óptica para comprobar. Comience la operación.
 - Si tiene un sistema de eyección por el extremo, tiene una cortina óptica. La Figura SEGURIDAD-11 muestra un ejemplo de un sistema con una cortina óptica. Prosiga con la verificación del funcionamiento del sistema de cortina óptica detallada a continuación.

Figura SEGURIDAD-11: Ejemplo de un sistema de cortina óptica

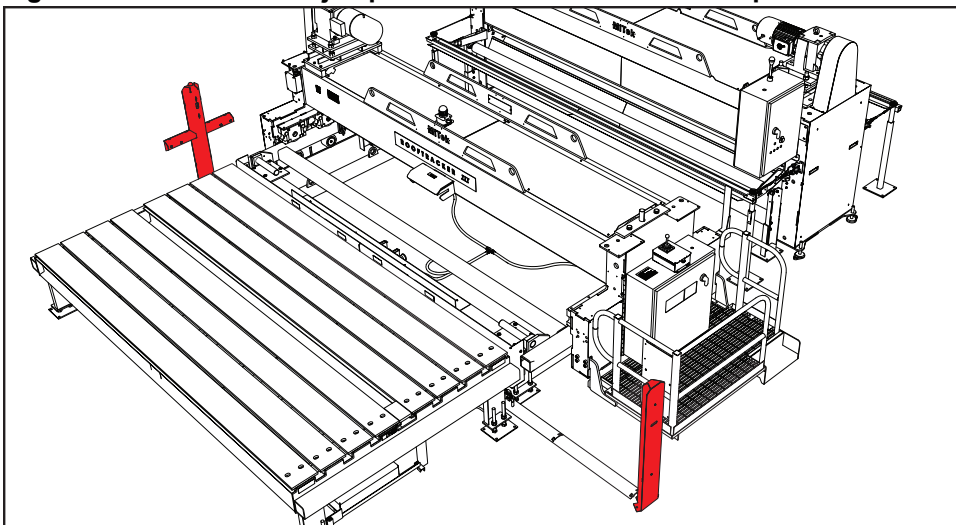

Verificación del funcionamiento del sistema de cortina óptica

Las cortinas ópticas se usan solamente con sistemas de eyección por el extremo.

Verificación del funcionamiento de los sensores de inhibición (muting)

La cortina óptica usa sensores de inhibición para detectar el pasaje del cabezal del pórtico sin activar un paro de emergencia. Revise los sensores de inhibición por medio de los siguientes pasos:

1. Mantenga presionado el botón “Reset” (Restablecer) en el gabinete eléctrico principal durante un segundo. Presione “Start” (Inicio).
2. Con la prensa en funcionamiento, mueva el cabezal del pórtico a través de la cortina óptica sobre el elevador del pórtico. Verifique que la prensa siga funcionando.
3. Bloquee y etiquete el gabinete eléctrico principal del cabezal del pórtico para evitar que este se mueva durante el resto de la prueba.

Verificación del funcionamiento de la cortina óptica

1. Con la prensa en funcionamiento, camine entre el transmisor y el receptor de la cortina óptica para bloquearla. El área aproximada por donde debería caminar se muestra en rojo en la Figura SEGURIDAD-12. Verifique que suceda lo siguiente:
 - los rodillos de la prensa deberían dejar de girar inmediatamente;
 - la luz en el gabinete eléctrico principal debería cambiar a rojo; y
 - la luz del soporte del transmisor de la cortina óptica debería parpadear en rojo.

Figura SEGURIDAD-12: Prueba de la cortina óptica

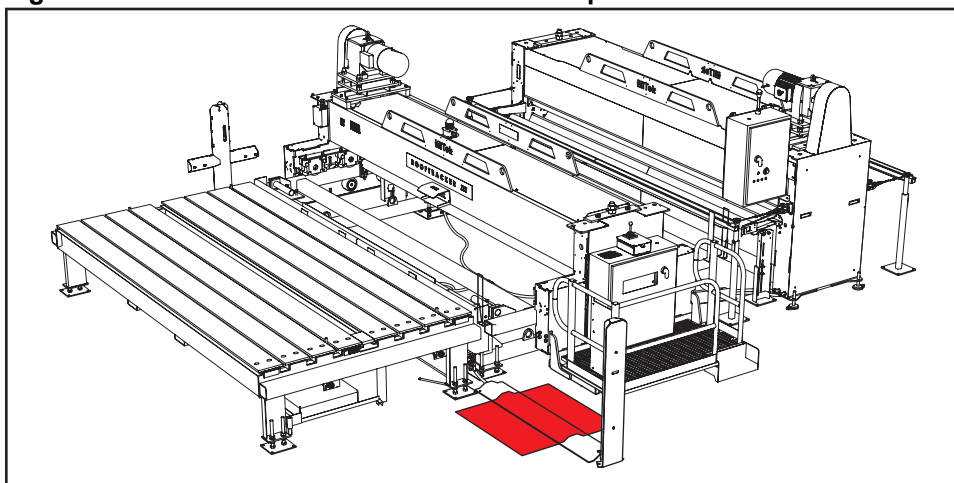

2. Camine hacia el gabinete eléctrico principal de la prensa. Intente arrancar la prensa. La prensa no debería arrancar.
3. Mantenga presionado el botón “Reset” (Restablecer) en el gabinete eléctrico principal durante un segundo.
4. Quite el candado y la etiqueta del cabezal del pórtico.
5. Comience la operación.

Zona Restringida

	⚠ PELIGRO
	<p>Manténgase alejado de la zona restringida cuando el equipo esté en uso. La presencia de personal en la zona restringida puede tener como consecuencia lesiones graves o incluso la muerte.</p> <p>Siempre observe que no haya personal en la zona restringida antes de operar el equipo.</p>

La zona restringida varía ligeramente de acuerdo con el diseño de la planta. Los siguientes son ejemplos de zonas restringidas.

Figura SEGURIDAD-13: Ejemplo de zona restringida para sistemas de eyección lateral



Figura SEGURIDAD-14: Ejemplo de zona restringida para sistemas de eyección por el extremo



Señalización de la zona restringida

La zona restringida deberá señalizarse de tal manera que todas las personas que se encuentren cerca del equipo puedan ver claramente el área que podría ser peligrosa.

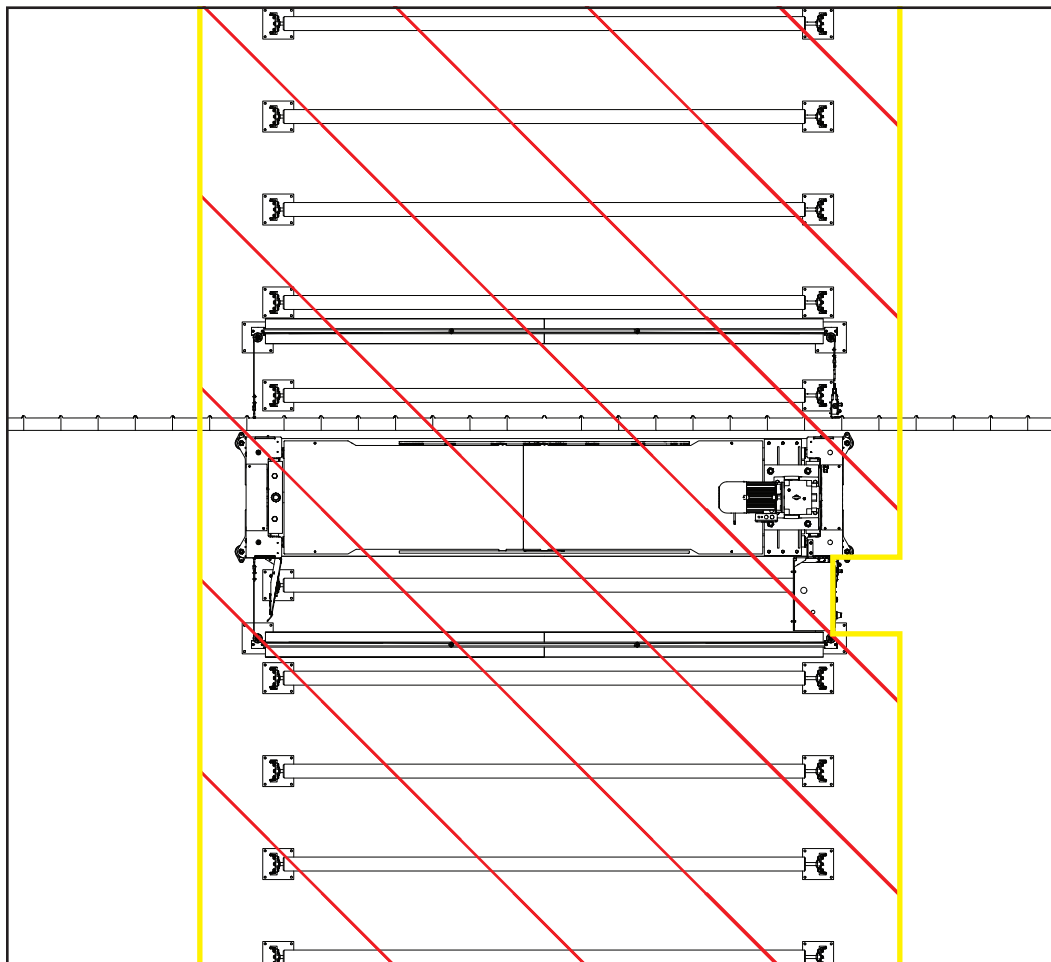
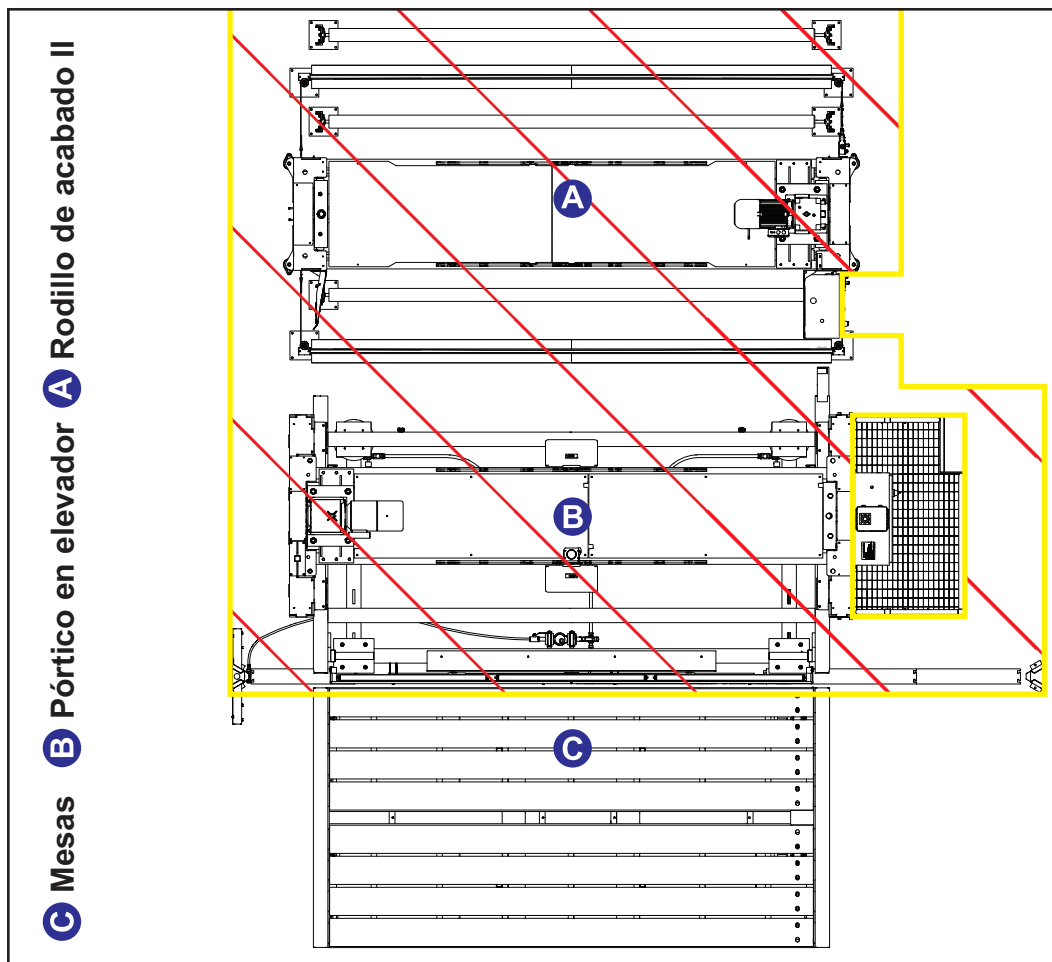
Definiciones de los símbolos de seguridad

Los símbolos de seguridad que se muestran en esta sección se pueden encontrar en todo el manual para indicar riesgos que están relacionados a esta máquina. Todo el personal que tiene que operar o dar mantenimiento a esta máquina debe familiarizarse con estos símbolos de seguridad y lo que significan.



Precaución para el usuario. Indica una condición en la cual podría ocurrir un daño al equipo que cause una lesión si no se siguen los procedimientos operativos. Para reducir el riesgo de daños o lesiones, lea los documentos acompañantes, y siga todos los pasos o procedimientos que se indican.



Peligro eléctrico. Indica alto voltaje peligroso dentro de un gabinete y/o la presencia de una fuente de alimentación. Para reducir el riesgo de incendio o choque eléctrico, no intente abrir el gabinete o intente ingresar en áreas donde se le han indicado que no debe ingresarse. Solo el personal de servicio calificado debe dar servicio.

Este equipo se debe operar solo con el tipo de fuente indicado en la etiqueta de identificación del fabricante. La instalación debe de cumplir con las secciones aplicables del código nacional de electricidad. Consulte su código local de construcción antes de instalarlo.



Riesgo de aplastamiento. Mantenga las manos lejos.



Peligro de ruido. El equipo produce ruido fuerte de más de 100 dBA durante su operación. Use el equipo de protección personal para proteger la audición cuando se encuentra cerca de este equipo.



Peligro de tropiezo. Ponga atención al caminar en el área.



Riesgo de rebote.



Mantenga las manos y el cuerpo lejos.



Superficie caliente. La temperatura de la superficie puede exceder los 158°F (70°C) durante la operación normal. No tocar.



Ventilar. Las ranuras y aberturas en el gabinete se proporcionan para ventilar y asegurar la operación confiable del equipo. Para proteger el equipo de sobrecalentarse, estas aberturas no deben estar bloqueadas o tapadas. Este equipo no debe de ubicarse en una instalación cerrada, como una abertura en la pared, a menos que se haya proporcionado ventilación adecuada ya que dará como resultado temperaturas altas.



Mantenga los pies lejos de las piezas en movimiento.



Mantenga las manos lejos de las piezas en movimiento.



Manguera de alta presión. Use el equipo de protección personal cuando trabaje en el equipo. Mantenga un nivel seguro de presión en todo momento.



Manguera hidráulica de alta presión. Usa el procedimiento seguro de operación en todo momento.



Utilice el equipo de cabestrante calificado para por lo menos ___ lb / ___ kg al levantar este equipo.



La operación de este equipo requiere el uso de equipo de protección personal.

No operar sin ponerse la ropa protectora requerida.



Refiérase al manual. Después de la instalación, lea la guía de usuario cuidadosamente antes de operar el equipo. Siga todas las instrucciones de operación y otras cuidadosamente.



Los circuitos tienen corriente. Bloquee/etiquete en la desconexión de flujo arriba antes de darle servicio.



Bloqueo en un estado desenergizado.



Punto de levantamiento. Para reducir la probabilidad de daño al equipo, utilice solo los puntos de levantamiento indicados en el manual.



Para reducir el riesgo de daño al equipo o lesiones al personal, mantenga la presión a niveles seguros.



El uso de equipo de levantamiento es obligatorio.



Consulte la hoja de datos de seguridad de materiales.



Lea todas las advertencias de seguridad e instrucciones antes de continuar.



Desenchufe el equipo antes de darle servicio.



Las piezas en movimiento peligrosas están ubicadas detrás de este panel de acceso. No opere este equipo a menos que todos los dispositivos protectores y cubiertas estén en su lugar.



No pise ni se pare en este equipo. Pisar o parar en este equipo puede resultar en una lesión grave.



No es un escalón. No pise ni se pare en esta ubicación.



No utilice los lubricantes no aprobados en este equipo.



No deseche con los residuos municipales.

Declaración de conformidad de seguridad

Es conforme eléctricamente a lo siguiente:

- NFPA 79
- El código eléctrico NEC
- Los gabinetes eléctrico conllevan UL 508A y el CUL para Canadá
- El circuito de seguridad es conforme a la Categoría 4 de monitoreo redundante

Es conforme mecánicamente a lo siguiente:



- 10CFR 1910
- ANSI B 11.19

Introduction

**Purpose
of Chapter**

This chapter explains how to navigate through the manual and how to contact MiTek Machinery Division Customer Service.

Introduction to the Manual

	 WARNING
	<p>Read this manual completely before using this equipment.</p> <p>Do not operate this equipment until you have a thorough understanding of all controls, safety devices, emergency stops, and operating procedures outlined in this manual.</p> <p>All hazard instructions must be read and observed. Failure to do so may result in economic loss, property damage, and/or personal injury.</p> <p>This manual must always be available to personnel.</p>

Purpose and Scope of This Manual

In order for this manual to be useful, it must be accessible.

This manual addresses the most recent version of the equipment as of the date listed on the title page. For earlier revisions, contact MiTek Machinery Division Customer Service.

This manual is a valuable training tool.

- The *Introduction* and *General Information* chapters discuss contact information for MiTek and provide basic information about the equipment.
- The *Operation* chapter teaches operators how to efficiently operate the machine.
- The *Maintenance* chapter details procedures specifically for maintenance personnel.
- The appendices provide valuable training materials and technical information to keep your equipment running.





	NOTICE
	<p>This manual addresses the operation and maintenance of the Finish Roller II only.</p> <p>This manual does not address or recommend methods of designing or building a truss.</p>

Understanding the Manual

Navigational Aids

The graphics used in Table 1-1 are used throughout the manual to communicate a specific type of information quickly.

Table 1-1: Navigational Aids

Graphic	Explanation
	<p>This icon is an important safety note.</p> <p>It indicates that you must lockout/tagout at the disconnect switch located on the equipment using approved methods described in OSHA CFR 1910.147 before continuing with the procedure.</p>
	<p>This icon specifies that certain tools are needed before a procedure begins.</p>
	<p>This icon provides additional information to supplement the main text.</p>
	<p>This icon indicates how to locate additional relevant information or resources.</p>

Drawing Set

A list of drawings can be found in the back of this equipment manual or in a separate 11x17 binder.

The drawing set is included with this manual. A list of the drawings can be found in the Maintenance Manual. The actual drawings are either in a separate 11x17 binder or in the back of the Maintenance Manual.

Additional Resources

Website

Visit the MiTek website at www.mitek-us.com for up-to-date information on all MiTek equipment. You may also find the following information there:

- The latest revisions of this manual
- Service bulletins pertaining to your equipment
- Support, safety, and training information
- Part numbers for ordering parts

Phone or E-mail Support

To obtain expert technical assistance or to order parts, contact MiTek Machinery Division Customer Service using one of the following methods.

Table 1-2: Contact Information

 Component Automation Customer Service Department 301 Fountain Lakes Industrial Dr. St. Charles, MO 63301
Parts Orders (w/part number) mitekparts@mii.com
Technical Assistance 1-800-523-3380 machinerysupport@mii.com
Website & YouTube Channel www.mitek-us.com https://www.youtube.com/mitek-usa

General Information

Purpose of Chapter

This chapter provides an overview of the equipment and the means to identify it.

Introduction to the Equipment

Purpose of the Equipment

The *Finish Roller II* completes the embedment of connector plates into trusses before the trusses are stacked.

Safety Compliance of the Equipment

Equipment shipped to a U.S. destination is compliant with NFPA 79, NEC 2009, and applicable OSHA regulations.

Description of the Equipment

The *Finish Roller II* consists of a frame housing two press rollers and two guide rollers. An electric motor powers the press rollers. The press rollers complete the embedment of the connector plates on both sides of the truss. The guide rollers keep the truss flat as it passes through the press rollers. The motor runs continuously or intermittently, depending on the mode in which the press is operated. The graphic on page 51 shows main components.

Figure 2-1: *Finish Roller II* Overview

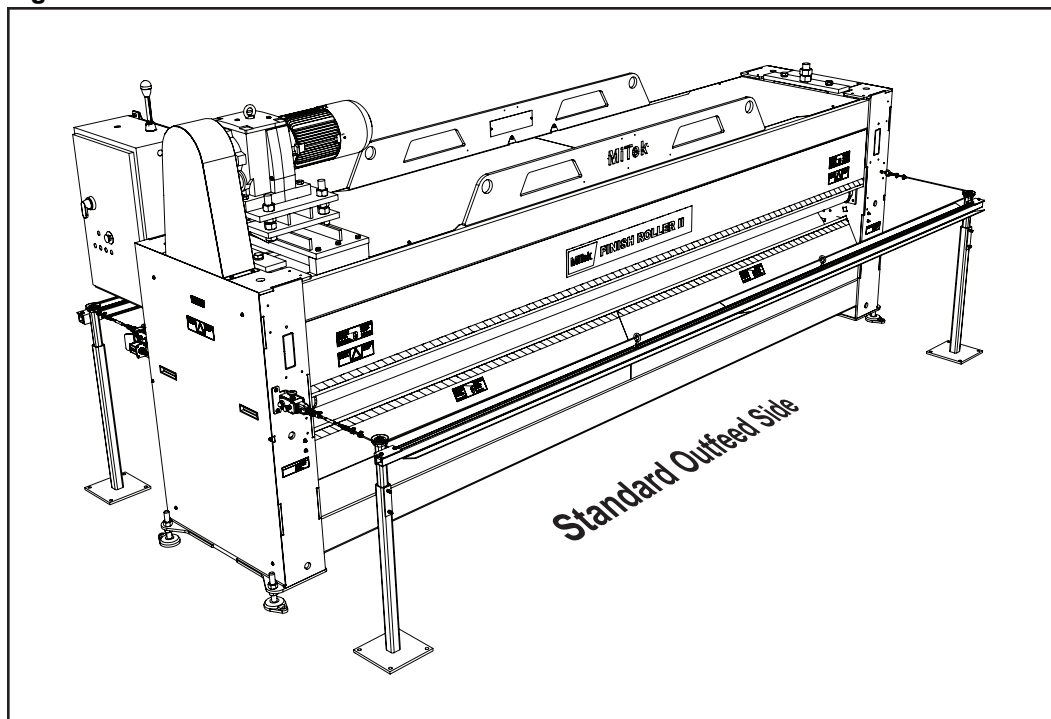

Figure 2-2: Components of the *Finish Roller II*

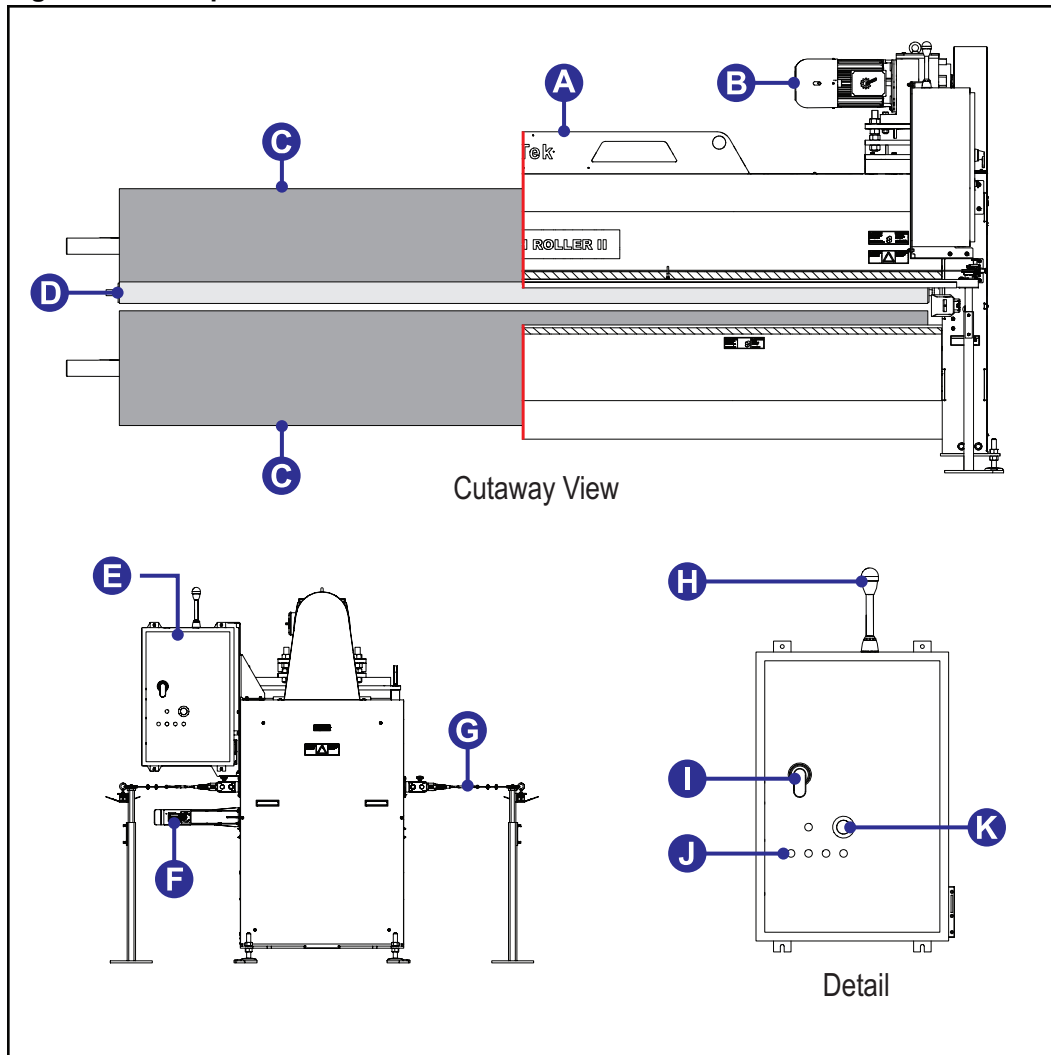

Table 2-1: Major Components of the *Finish Roller II*

Letter	Description
A	Lifting Lug
B	Gearmotor
C	Press roller
D	Guide roller
E	Electrical enclosure
F	Photoelectric sensor mounted to a lumber guide
G	Pull-cord (perimeter safety cable) (E-stop)
H	Beacon
I	Disconnect switch
J	Controls
K	E-stop pushbutton

Identifying Your Machine

Table 2-2: Top-Level Part Numbers

Part	Part Number
<i>Finish Roller II (3' 5" rollers)</i>	68630-501
<i>Finish Roller II (7' rollers)</i>	68631-501
<i>Finish Roller II (7' 6" rollers)</i>	68632-501
<i>Finish Roller II (8' rollers)</i>	68633-501
<i>Finish Roller II (12' 6" rollers)</i>	68634-501
<i>Finish Roller II (14' rollers)</i>	68500-501
<i>Finish Roller II (16' rollers)</i>	68635-501

Main Components and Optional Components

Table 2-3 lists some of the main components that are included with all versions of this equipment.

Table 2-3: Major Components

Component	Description of Role	Part No.
Gearmotor	Drives the press rollers to move truss and embed plates	480401
Electrical enclosure	Houses important electrical components inside and features controls on the outside	90646-502
Pull-cord (perimeter safety cable)	Stops the rollers from turning in an emergency	63060-501 or -502 63060-601 or -602
Photoelectric sensor	Senses the presence of a truss and signals the VFD to start running in automatic mode	515000
Press rollers	Complete embedment of connector plates	Varies by model (see page 125)
Guide rollers	Prevent bowing as truss passes through the press rollers	Varies by model (see page 125)

Table 2-4 lists some of the optional components that are included with some versions of this equipment.

Table 2-4: Optional Components

Component	Description	Part No.
Light curtain for end-eject systems	Guards against the entry of people into the restricted zone	90649-501

Technical Specifications

Table 2-5: General Specifications

Specification	Technical Data
Truss capacity (thickness)	2" nominal minimum
Truss capacity (thickness)	4" nominal maximum
Horsepower of motor	10 hp
Speed of motor	1750 rpm
Lumber processing speed	100 fpm
Roller length	3'-5", 7', 7' 6", 8', 12' 6", 14', or 16' (depending on model)
Roller diameter	24"
Roller baffles	3 per roller
Roller shaft diameter	4" nominal
Operating Temperature	min. 32°F (0°C)

Table 2-6: Approximate Dimensional Specifications

Model	Length	Width*	Width**	Height
68630-501 (3' roller)	6' 1"	8' 7"	5' 4"	7' 6"
68631-501 (7' roller)	9' 8"	8' 7"	5' 4"	7' 6"
68632-501 (7' 6" roller)	10' 2"	8' 7"	5' 4"	7' 6"
68633-501 (8' roller)	10' 8"	8' 7"	5' 4"	7' 6"
68634-501 (12' 6" roller)	15' 2"	8' 7"	5' 4"	7' 6"
68500-501 (14' roller)	16' 8"	8' 7"	5' 4"	7' 6"
68635-501 (16' roller)	18' 8"	8' 7"	5' 4"	7' 6"
* with pull-cord stands and pull-cords attached in standard position				
** without pull-cord stands or pull-cords attached				

Table 2-7: Approximate Weight Specifications

Model	Technical Data
68630-501 (3' roller)	5885 lbs
68631-501 (7' roller)	8553 lbs
68632-501 (7' 6" roller)	8910 lbs
68633-501 (8' roller)	9305 lbs
68634-501 (12' 6" roller)	12,491 lbs
68500-501 (14' roller)	13,515 lbs
68635-501 (16' roller)	14,885 lbs

Installation

Purpose of Chapter

This chapter provides a brief overview of the responsibilities in the installation process.

Installation Requirements

Environmental Requirements

Operating Temperature

As indicated in the general specification, the press operates properly in its intended ambient temperature, from 32 to 122°F (0 to 50°C). A heater keeps the main electrical enclosure between 50-80°F (10 to 27°C) when the machine 3-phase power is on.

Relative Humidity

The press operates properly in an atmosphere with 45 to 85 percent relative humidity.

Transportation and Storage

The press withstands or has been protected against transportation and storage temperatures from -13 to 158° Fahrenheit (-25 to 70° Celsius). It has been packaged to prevent damage from the effects of normal humidity, vibration, and shock.

	ENVIRONMENTAL
	<p>Do not discard machinery into the municipal waste stream.</p>

Infrastructure Requirements

Flooring Requirements

The press needs to be installed on a floor made of 3500 PSI concrete that is a minimum of 6" thick. The floor needs to be level within 3" across the area of installation.

Shelter Requirements

MiTek recommends placing the press inside where it is protected from the elements. However, the press may be placed outside as well.

- The main electrical enclosure on the press is NEMA 3R rated.
- The pull-cord switches are NEMA 6 rated.

If the press is placed outside, MiTek recommends placing the press under an overhang or other type of shelter to keep the press protected from precipitation.

Electrical Requirements

Specifications for the electrical system of the press are detailed in Table 3-1.

Table 3-1: Electrical System Requirements

Specification	Technical Data
Voltage	230VAC
Cycles (Hz)	60 HZ
Phases	3
Full-load amps	25.8 amps
Disconnect switch fuses	60 amps

MiTek provides a transformer to transform other supply voltages into 230VAC if necessary.

Installing the Press

Gathering Tools

Before beginning the installation of the press, gather the tools listed here.

- Standard wrench set
- Standard socket wrench set
- Standard hex key set
- Level
- Straight 2x6 boards (2)
- Hammer drill with 1/2" bit
- Impact driver and impact sockets

Choosing a Location for the Press

The press may be installed in a variety of ways. Before moving the press into a location, consult the installation guide that came with this manual to determine the best installation option for your particular plant layout. Figure 3-1 shows a sample installation.

Figure 3-1: Sample Installation

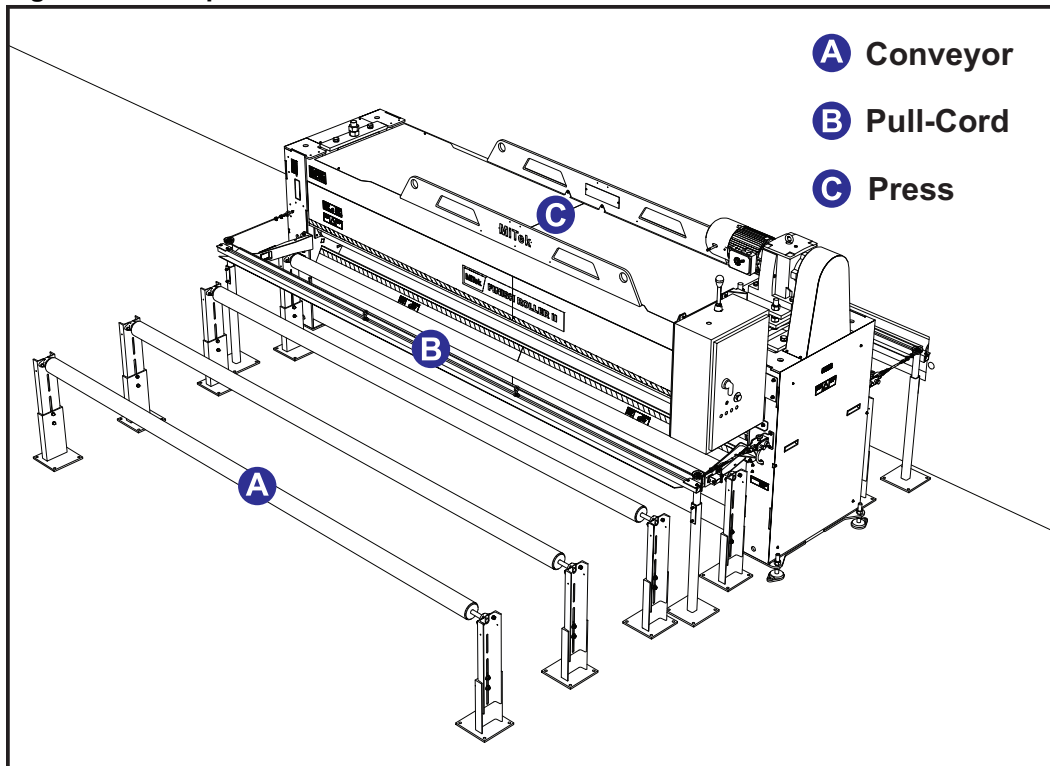

Lifting and Moving the Press



	WARNING
	<p>Do NOT lift the press by any other method other than the one described here.</p> <p>Lifting the press using any other method other than the one described here may result in damage to the press or injury to bystanders.</p>

Table 3-2 shows the weights of the various sizes of presses. Use a properly sized fork truck when lifting your press.

Table 3-2: Finish Roller II Weights

Model	Weight
68630-501 (3' roller)	5885 lbs
68631-501 (7' roller)	8553 lbs
68632-501 (7' 6" roller)	8910 lbs
68633-501 (8' roller)	9305 lbs
68634-501 (12' 6" roller)	12,491 lbs
68500-501 (14' roller)	13,515 lbs
68635-501 (16' roller)	14,885 lbs

Using a properly sized fork truck, lift the press by inserting the forks through the slots on the press shown in Figure 3-2. You may support the press from the bottom using an additional fork truck if necessary.

Figure 3-2: Lifting Lug Location

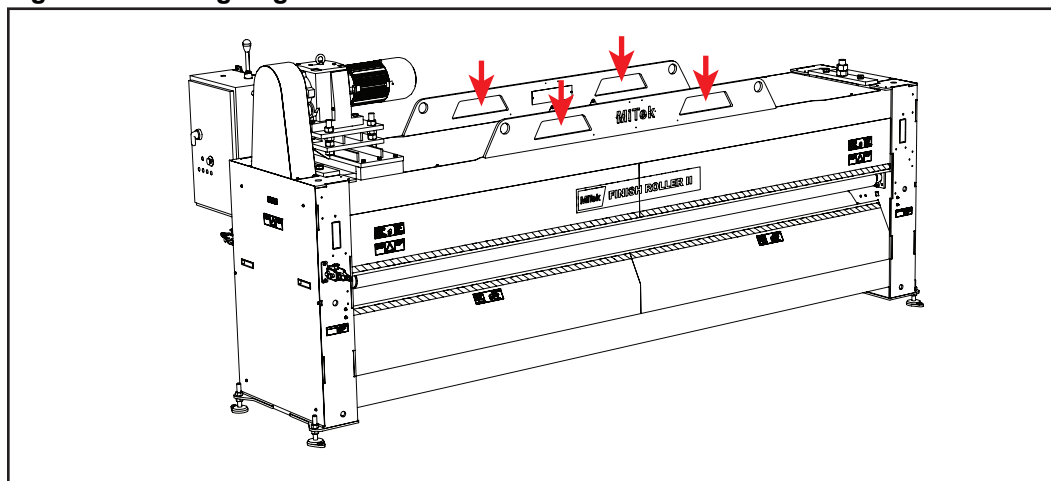

Verifying Components and Hardware

Before installing the press, verify that the following components and hardware arrived with the press. Most of the parts are packaged in a box that arrives with the press. Table 3-3 lists the included components and hardware. Note that the graphics in Table 3-3 are not drawn to scale.

Table 3-3: Components and Hardware Included with Press

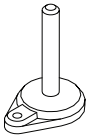
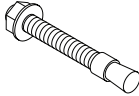
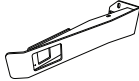

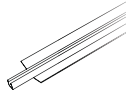
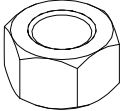



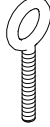
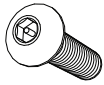

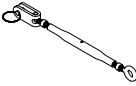
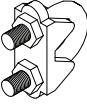

Image	Description	Part No.	Qty.
	Foot	162100	4
	Anchor bolt	305022	20
	Lumber guide	68512-501	2
	Pull-cord stand	See drawing 63060-XXX.	4
	Pull-cord support (12' 6" roller and longer only)	See drawing 63060-XXX	Varies by model
	Hex nut (1"-8)	361619	8
	Hex nut (3/8"-16)	361605	6
	Lock washer (3/8")	364042	Varies by model

Image	Description	Part No.	Qty.
	Flat washer (3/8")	365642	Varies by model
	Eye bolt (3/8"-16X2-1/2")	358019	Varies by model
	Tamper-resistant button-head cap screw (3/8"-16X1-1/2")	354003	16
	Tamper-resistant hex key	354004	2
	Thimble	271026	4
	Turnbuckle	271055	2
	Pull-cord clamp	271002	8
	Channel nut	200012	12
	Pull-cord	270026-XXX	2

Removing the Pull-Cord Support

Some presses have pull-cord supports. The pull-cord supports eventually install between pull-cord stands. When the press arrives, the supports may be attached to the press mouth on both the infeed and the outfeed sides. An example is shown in Figure 3-3. If your press has a pull-cord support attached to it, remove the support. Discard the hardware attaching the support to the frame.

Figure 3-3: Pull-Cord Support Location When Press Arrives

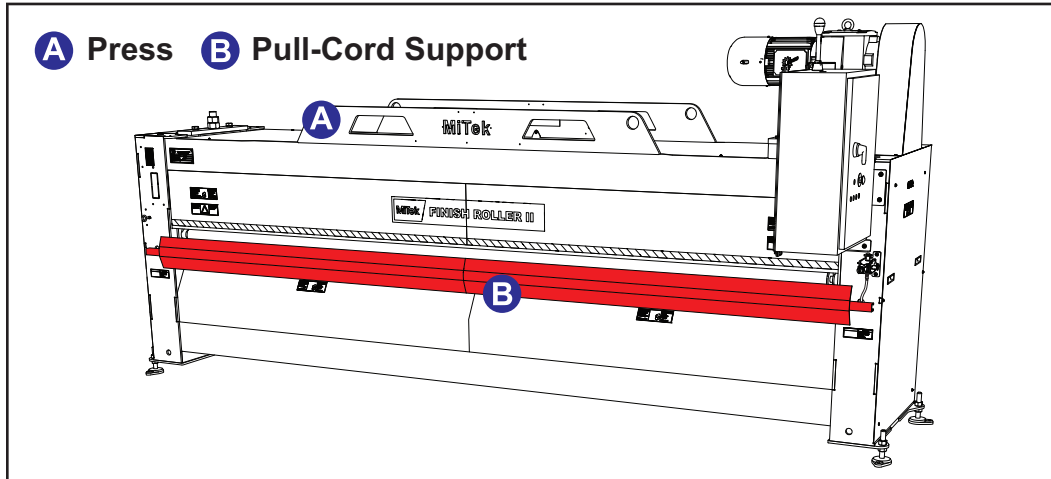

Checking and Adjusting the Height of the Press

After you have placed the press, make sure the press has at least one conveyor installed on either side of it. Then check the height of the bottom roller of the press by using the following steps.

1. Place two straight boards into the press and allow them to rest on the first roller next to the press infeed. See Figure 3-4.
Make sure that the boards are straight before using them. If they are not, you may adjust the height of the press incorrectly.

Figure 3-4: Placing Board into the Press

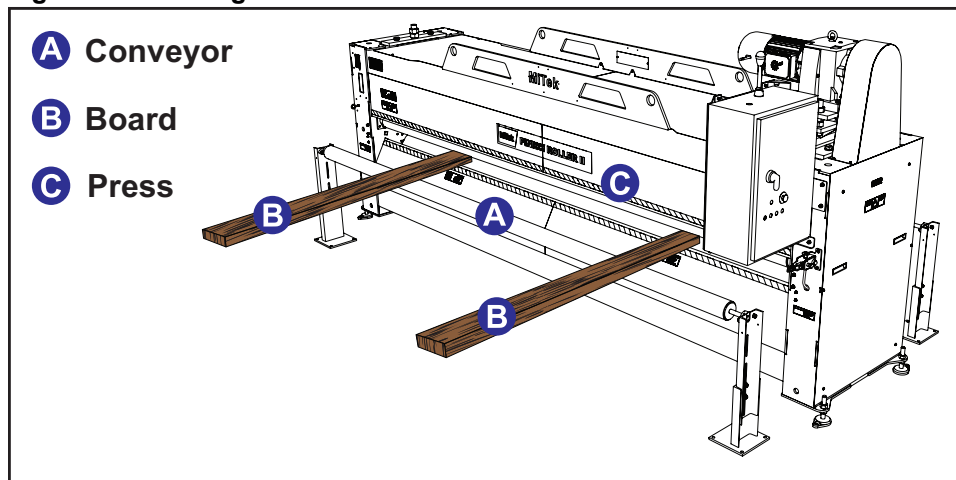

2. Place a level on the boards to see if the conveyor roller and the bottom press roller are level.
3. Repeat steps 1 and 2 with the first conveyor on the press outfeed.
4. Use the adjustment feet shown in Figure 3-5 to raise or lower the press. The bottom press roller should be the same height as the conveyors.

Figure 3-5: Adjusting Feet on Press

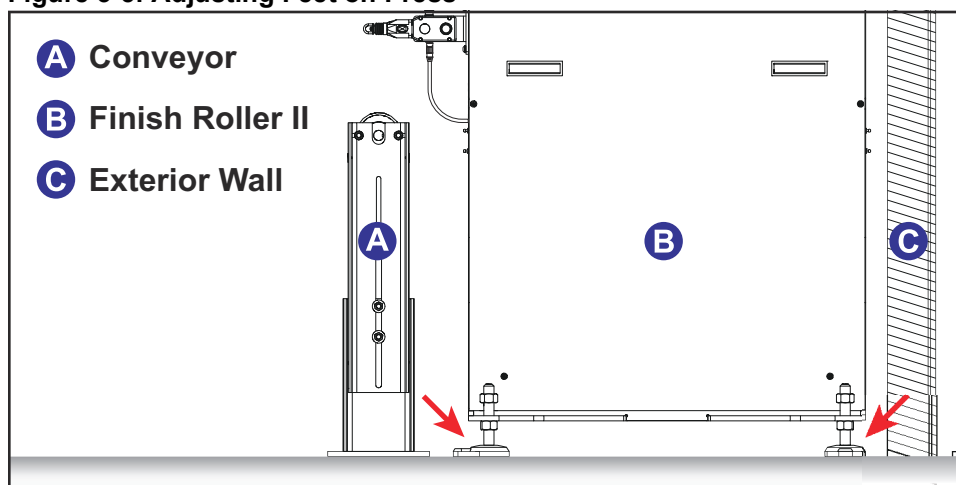

5. Make sure that the conveyors on the outfeed side of the press are set to the same height as the bottom press roller.

Leveling the Press

Once the press is set to the same height at the conveyors, place a level against the bottom press roller as close to the top of the roller as possible. The bottom press roller is highlighted in red in Figure 3-6.

Figure 3-6: Checking Level of the Bottom Roller

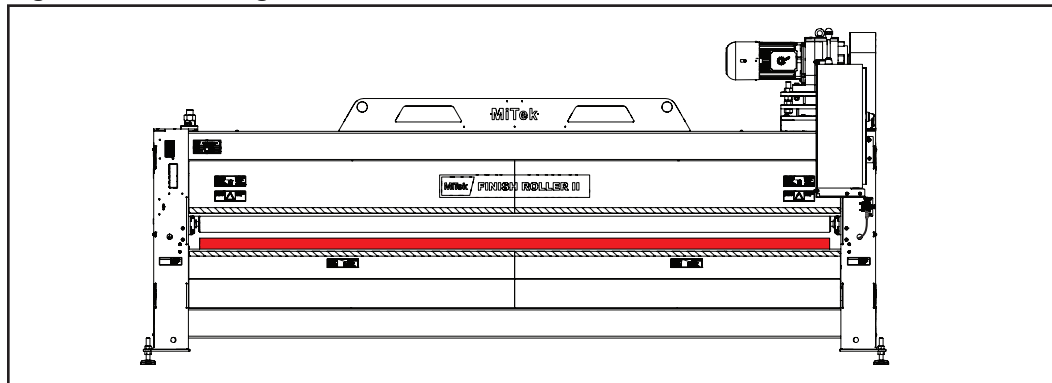

- If the bottom roller is level, tighten the top nuts on the threaded rods of the feet. Continue to the next section.
- If the bottom roller is not level, adjust the bottom nuts on the threaded rods of the feet until the bottom roller is level. Then continue to the next section.

Installing the Lumber Guides

After leveling the press, install the lumber guides. The lumber guides are yellow arms that are mounted on the infeed side of the press. One lumber guide has a reflector mounted to it. The other lumber guide has a photoelectric sensor mounted to it.

Lumber guides may be mounted either to the press frame directly (described below) or to strut mounted to the inside of a wall, if the press is on the other side of the wall.

1. Locate the mounting holes on the end of the press opposite the main electrical enclosure as shown in Figure 3-7. Use washers and socket-head cap screws to attach the lumber guide with the reflector to the frame.
Make sure that the lumber guide is adjusted as far down as the slots allow.

Figure 3-7: Attaching Lumber Guide with Reflector to Frame

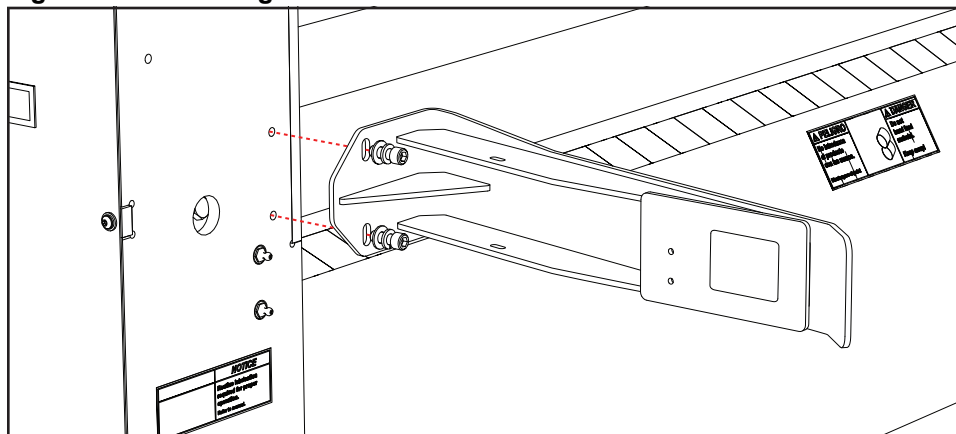

Always mount the lumber guides to the side of the press used as the infeed.

2. Locate the mounting holes on end of the press closest to the main electrical enclosure as shown in Figure 3-8. Use the washers and socket-head cap screws to attach the lumber guide with the photoelectric sensor to the frame.

Make sure that the lumber guide is adjusted as far down as the slots allow.

Figure 3-8: Attaching Lumber Guide with Photoelectric Sensor to Frame

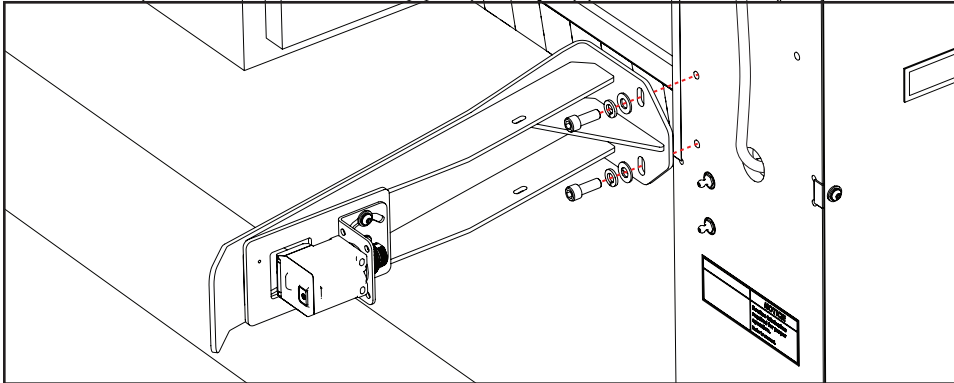

3. Remove the end guard nearest the photoelectric sensor. Locate the black photoelectric sensor cable inside of the frame.
4. Run the cable through the frame and connect the female connector to the photoelectric sensor. See Figure 3-9.

Figure 3-9: Connecting Cable to Photoelectric Sensor

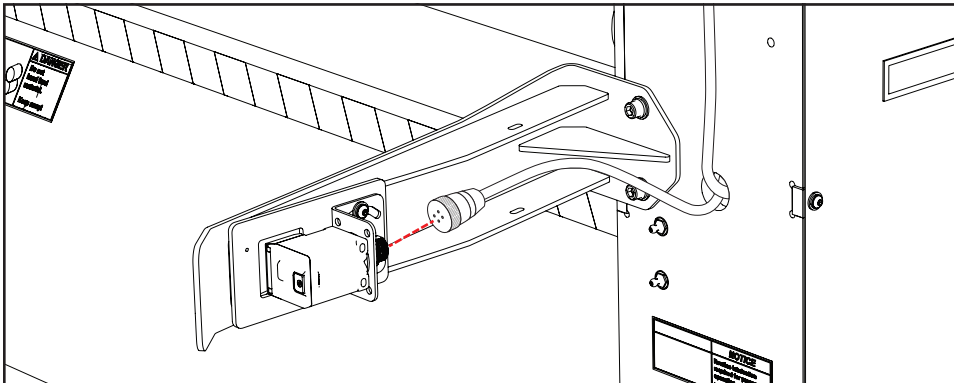

5. Replace the guard.

Installing Pull-Cord Switches

The press ships with pull-cord switches mounted directly to the frame. Either the infeed or outfeed pull-cord switch may be moved from the press frame and mounted to a wall if the press is installed against a wall or door.

- If you are keeping both pull-cord switches mounted to the frame, install two eye bolts in the holes on the opposite end of the press from the pull-cord switches. The holes are the middle holes in a triangular pattern of holes. Skip to Installing the Pull-Cord Switch Stands on page 65.
- If you are moving a pull-cord switch to a wall, MiTek recommends mounting the switch and eye bolt to strut. See Figure 3-10 below as a reference. When you finish mounting the pull-cord switch and eye bolt to the wall, continue with the instructions on page 65 below.

Figure 3-10: Pull-Cord Switch Mounted to Wall

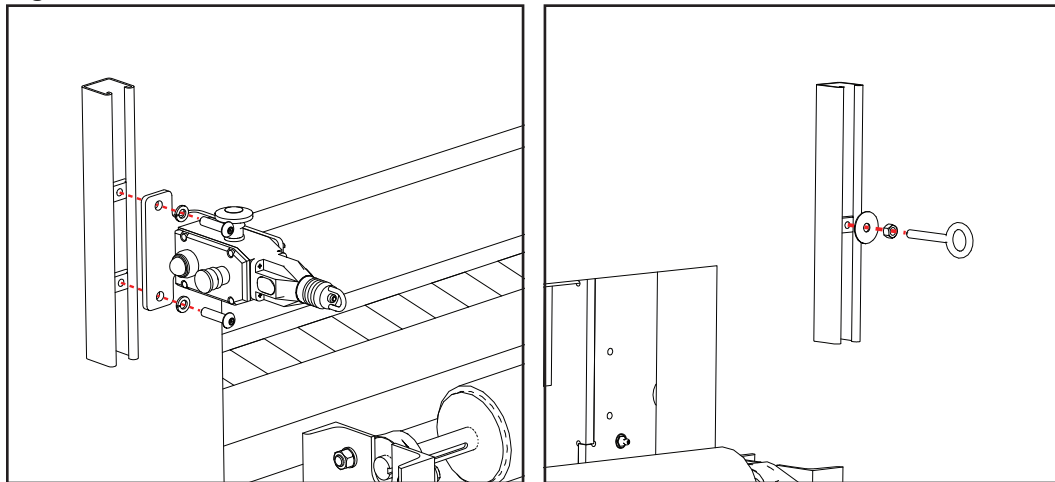

Left side of outfeed shown above

Right side of outfeed shown above

Installing the Pull-Cord Switch Stands

1. Position the pull-cord stands in their approximate locations with their angle brackets facing away from the press. Note that the stands should be a minimum of 26" from the pull-cord switch.

Do not anchor the pull-cord stands yet.

Figure 3-11: Placing Pull-Cord Stands

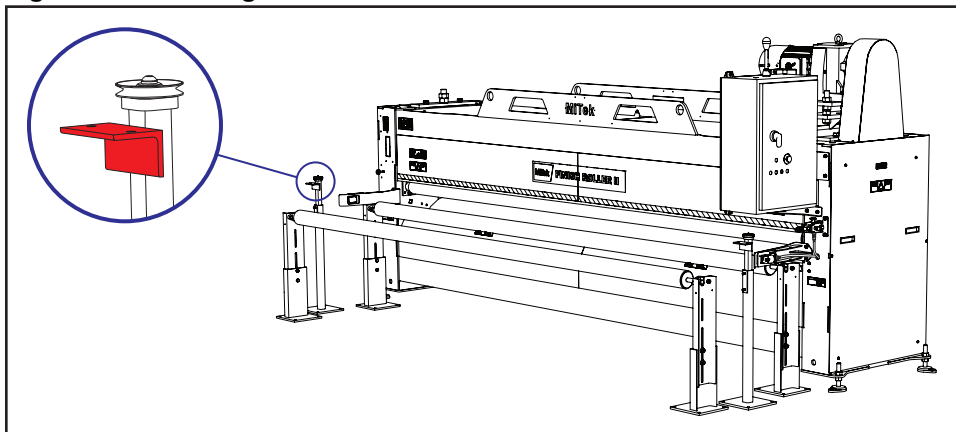

2. Loosen the hex-head cap screws on the bottom half of the pull-cord stands. Adjust the top halves of the stands so that sheaves (pulleys) are even with pull-cord switch and the middle of the eye bolt on the frame. See Figure 3-12. Then tighten the hex-head cap screws.

Figure 3-12: Sheave Height

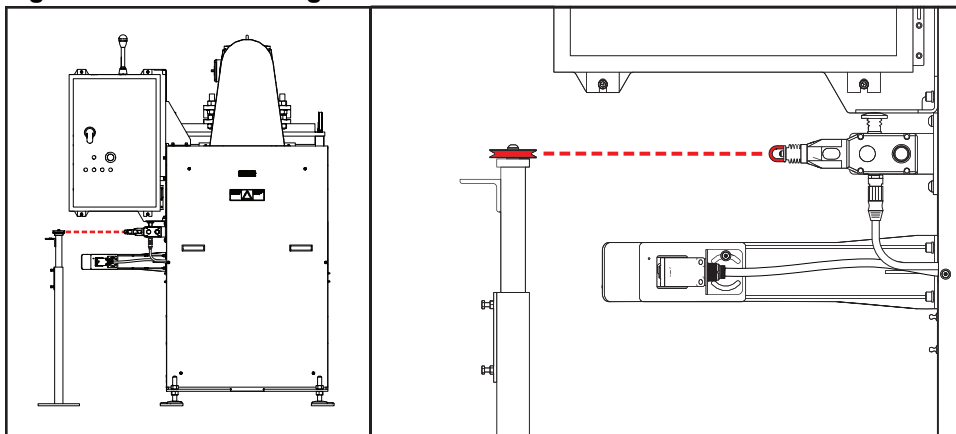

Eye bolt not visible in the graphic above

3. Continue based on the size of your press.
 - If you have a press with 8' rollers or shorter, you do not have a pull-cord support to install. Skip to step 7 on page 66.
 - If you have a press with rollers longer than 8', you have a pull-cord support to install. Continue to step 4 on page 66. You need an extra person for the following steps.

4. Install the tamper-resistant, button-head cap screws, washers, and channel nuts in the holes on both of the angle brackets.

Figure 3-13: Installing Hardware in the Angle Bracket of the Pull-Cord Stand

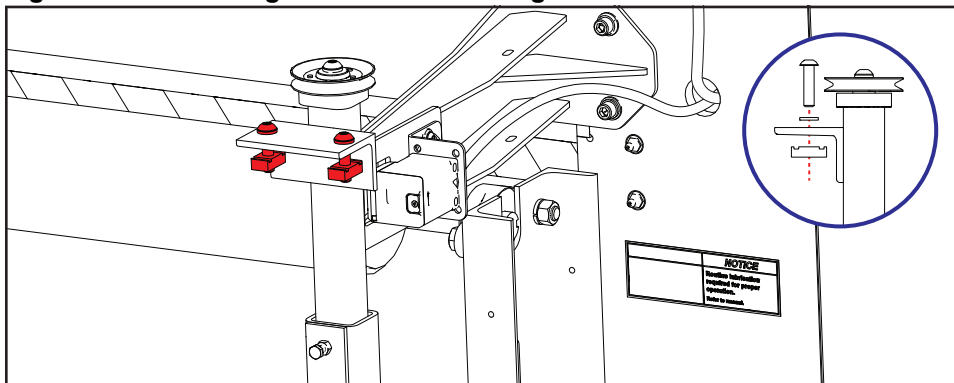

5. Slide the pull-cord support onto the channel nuts. Tighten the tamper-resistant, button-head cap screws.
If necessary, slide the stands apart to fit the pull-cord support onto the channel nuts.

Figure 3-14: Installing the Pull-Cord Support

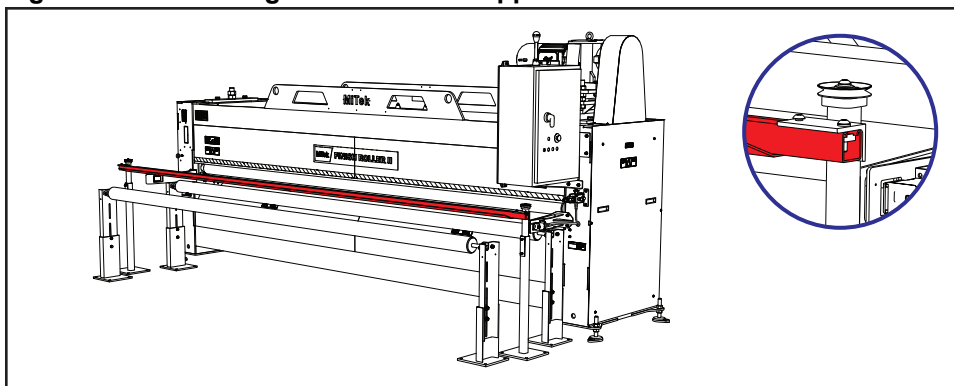

6. Using the channel nuts, washers, and nuts, install the eye bolts in the top of the pull-cord support equal distances from each end.

Figure 3-15: Installing Eye Bolts into Pull-Cord Support

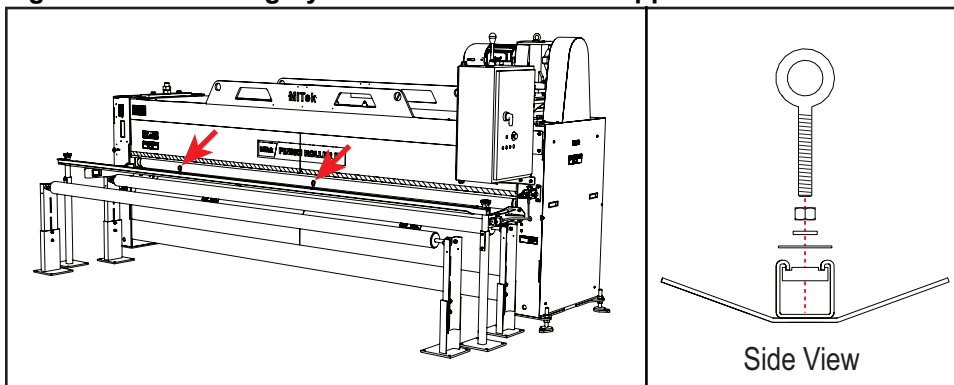

7. Make sure that the stands are square to the press frame. Using the anchor bolts, anchor the pull-cord stands to the ground.
8. Repeat steps 1 through 7 with the stands on the other side of the press.

Installing the Pull-Cords

1. Install the thimble through an eye bolt. Run 6" to 8" of one end of the pull-cord around the thimble and double the pull cord back on itself. Install the pull-cord clamps onto the pull-cord. See Figure 3-16.

Figure 3-16: Thimble and Pull-Cord Clamps Assembly on Pull Cord

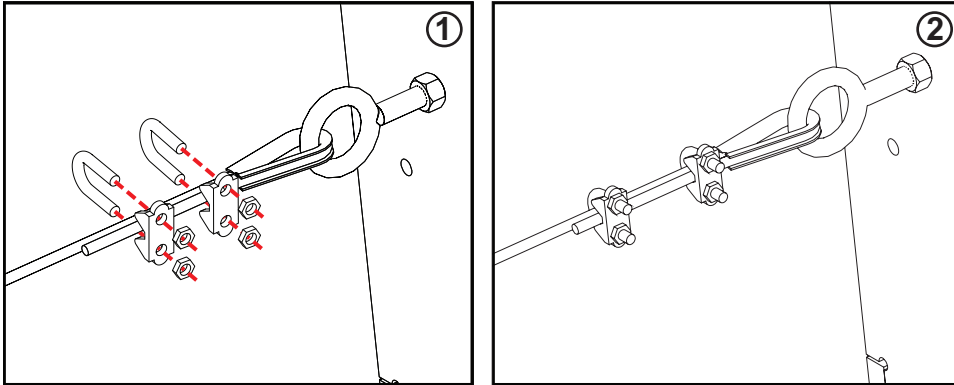

2. Place the thimble through the eye bolt of the turnbuckle. Connect the clevis and pin to the end of the pull-cord switch. See Figure 3-17.

Figure 3-17: Thimble and Turnbuckle on Pull-Cord Switch

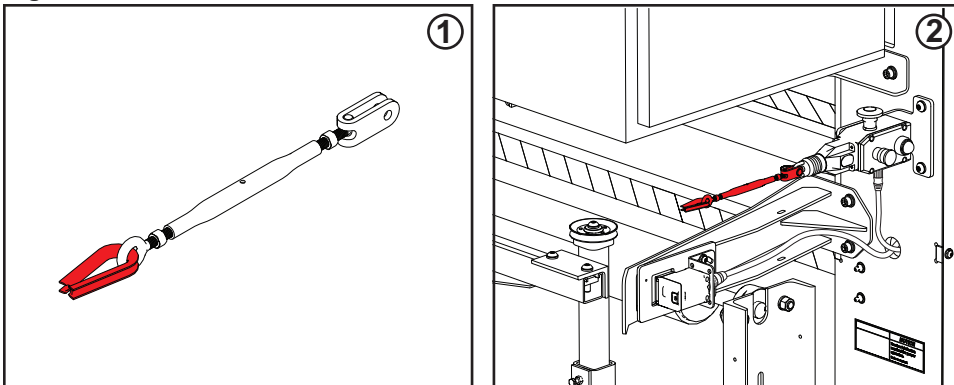

3. Route the pull-cord around the sheaves as shown in Figure 3-18.
If you installed the pull-cord support, make sure to route the pull-cord through the eye bolts on the pull-cord support.

Figure 3-18: Routing Pull-Cord

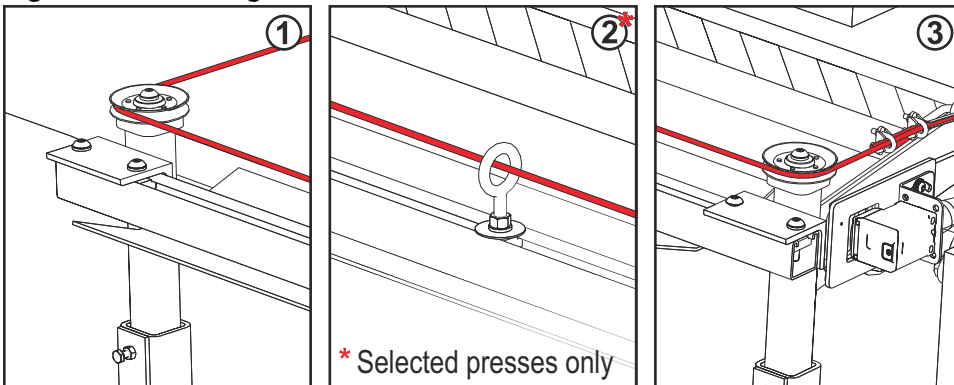

4. Route the pull-cord around the thimble attached to the turnbuckle. Keep the pull-cord tight. Attach two cable clamps in the same way as described in step 1 on page 67.

Figure 3-19: Pull-Cord Clamps on Pull Cord

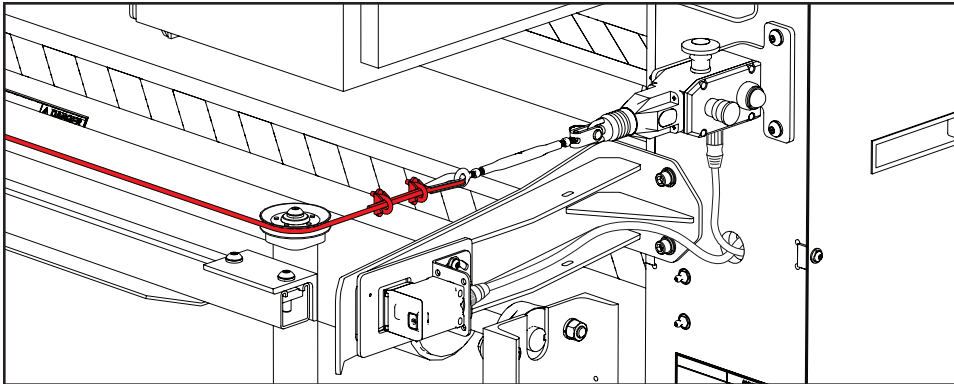

5. Trim excess pull-cord.
6. Install the other pull-cord on the opposite side of the press.

Tensioning the Pull-Cords

After installing the pull-cords on both sides of the press, tension both pull-cords according to the instructions on page 109. The press does not function if the pull-cords are not tensioned properly.



Connecting Cables to the Pull-Cord Switches

Make sure that each pull-cord switch has a yellow cable connected to its bottom. If the cable is not connected to the switch, remove the end guard, pass the cable through the hole in the frame, connect the cable to the bottom of the pull-cord switch, and replace the end guard. See Figure 3-20.

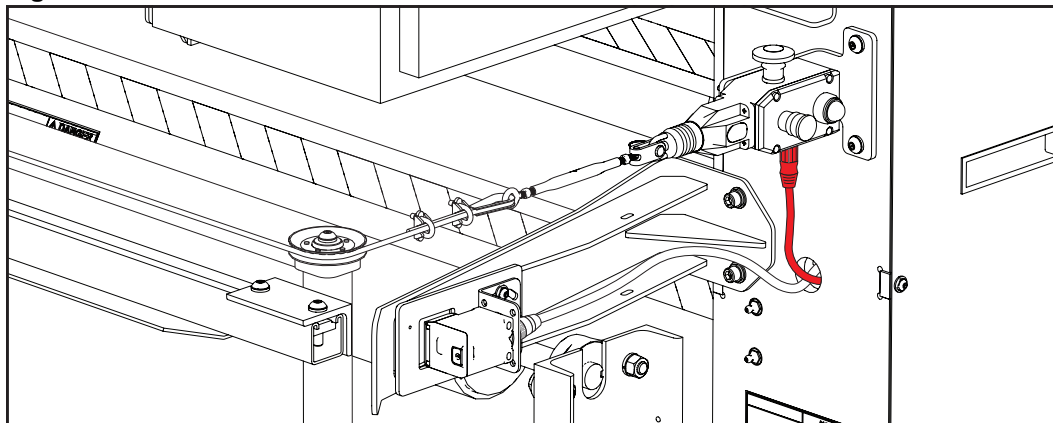
Figure 3-20: Cable Connected to Pull-Cord Switch



Connecting Power to the Press



	 WARNING
	<p>ELECTROCUTION HAZARD.</p> <p>All electrical work must be performed by a qualified electrician.</p> <p>Verify that all power to the machine has been turned off and follow approved lockout/tagout safety procedures before performing any maintenance.</p> <p>If it is absolutely necessary to troubleshoot an energized machine, follow NFPA 70E for proper procedures and person protective equipment.</p>

Supply 230VAC, three-phase power to the main electrical enclosure. See drawing 90646, included in the drawing set that accompanies this manual, for details about the electrical system.

Checking Motor Rotation

Check that both Finish Roller II rollers are rotating toward the infeed side, so that the truss is clamped between the two rollers and moved through the machine to the outfeed side. If the rollers are not rotating the correct direction, see page 88.

Performing the Safety Test

	 WARNING
	<p>Make sure that the press passes all parts of the safety test before beginning operation.</p> <p>Operating a press that has not passed the safety test may result in severe physical injury or death.</p>

Follow the instructions starting on page 10 to make sure that all safety devices are functioning properly. Once you have successfully completed the safety test, continue to *Aligning the Photoelectric Sensor*.

Aligning the Photoelectric Sensor

Turn the disconnect switch handle to the On position. Align the photoelectric sensor on the lumber guide according to the instructions on page 106.

Aligning the Light Curtain for End-Eject Systems

End-eject table systems require a light curtain between the table and the Finish Roller II. Turn the disconnect switch handle to the On position. Align the light curtain transmitter and receiver with each other according to the instructions on page 111.

Verifying All Rollers are at Correct Height

1. Place a truss (or several boards) with plates partially embedded on the conveyors on the infeed side of the Finish Roller II.
2. Using all operating safety standards, run the truss through the Finish Roller II.
3. Examine the plates.
 - If they are completely embedded the test was successful.
 - If they are not, adjust the guide rollers and/or the press rollers as instructed starting on page 101.

Marking Restricted Zone

Marking Area on Your Own

The restricted zone must be marked so everyone near the equipment can clearly see the area where danger may exist. The customer is responsible for marking the restricted zone.

Installing MiTek Restricted Zone Tape

Your equipment arrived with Service Bulletin SB181, which includes restricted zone tape and instructions for installing it.

The service bulletin is available online (www.mitek-us.com) as well as through the MiTek Machinery Division Customer Service Department. Follow the instructions contained in SB181 to install the restricted zone tape.



Customer Service
is available at
800-523-3380
Monday through
Friday.









Operation

**Purpose
of Chapter**

This chapter describes operating mechanisms on this machine and the procedure to operate it in most circumstances.

Before You Begin

Safety Operating Notes

	 WARNING
	<p>ELECTROCUTION AND CRUSH HAZARDS.</p> <p>Read this section AND the safety section in the preliminary pages before operating or maintaining this machine.</p> <p>Do not operate this machine until you have a thorough understanding of all controls, safety devices, E-stops, and operating procedures outlined in this manual.</p> <p>Read and observe all warnings. Failure to do so may result in economic loss, property damage, and/or personal injury.</p> <p>This manual must always be available to personnel operating and maintaining this machine.</p>
	 WARNING
	<p>CRUSH AND CUT HAZARD.</p> <p>Before turning on the machine, make sure that all personnel and other machines are out of the restricted zone (see page 15 and following pages for more details).</p>
	 WARNING
	<p>Do not operate this machine unless all guards and safety devices are in place.</p> <p>Only qualified maintenance personnel shall repair, remove, or replace guards and safety devices.</p>
	 WARNING
	<p>The operation of this machine requires the use of PPE. Do not operate without wearing required protective clothing.</p> <p>Operating this machine without proper PPE may result in injury.</p>

Stopping the Press

The Finish Roller II stops in four possible ways.

- The Stop button on the main electrical enclosure is pressed.
- An E-stop pushbutton on the main electrical enclosure or on the pull-cord switch is pressed.
- A pull-cord is pulled.
- The light curtain is broken by any object other than a gantry head (only applies to end-eject systems).
- An E-stop pushbutton on an interlocked machine is pressed (only applies to presses with interlocked machines).

Use E-stops only in emergencies. Using the E-stop to stop the press regularly causes excessive wear.

E-Stop Pushbuttons

E-stop pushbuttons are shown in Figure 4-1. To activate a pushbutton, push the button in. The press no longer operates.

Figure 4-1: E-Stop Pushbutton

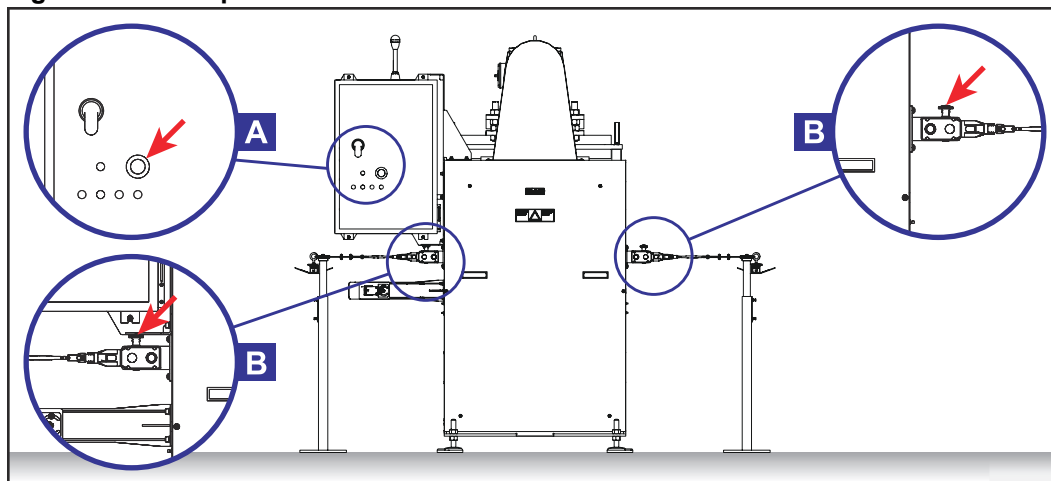

A Pushbutton on Electrical Enclosure **B** Pushbutton on Pull-Cord Switch

After an E-stop, the press needs resetting before it runs again.

1. Reset the pushbutton depending on which E-stop pushbutton was pressed.
 - To release the pushbutton on the main electrical enclosure, pull it.
 - To reset an E-stop pull-cord switch, press the blue Reset button on the tripped switch.
2. Reset the entire safety circuit by pressing the blue Reset button on the electrical enclosure and holding it for one second.
3. Resume operation.

Pull-Cord (Perimeter Safety Cable)

Pull the pull-cord to cut power to the control circuit and stop the press. If tensioned properly, the pull-cord should trigger an E-stop after it moves 3" to 4" from its resting position.

After someone pulls a pull-cord and triggers an E-stop, you must reset the press.

1. Press the blue reset button on the switch on the same side as the pull-cord that stopped the press.
2. Reset the entire safety circuit by pressing the blue reset button on the electrical enclosure and holding it for one second.
3. Resume operation.

Refer to page 108 for the location of the pull-cord.

Light Curtain (Perimeter Access Guarding)

Presses intended for end-eject systems include a light curtain. When objects other than gantry heads pass through the light curtain, the press stops immediately.

When a gantry head passes through a light curtain, muting sensors detect the gantry head and prevent the light curtain from triggering an E-stop.

Refer to page 110 for the location of the light curtain.



See page 109 for more information about pull-chord tensioning.

Disconnect Switch

Figure 4-2 shows the location of the disconnect switch. Turning the disconnect handle to the On position supplies electrical power to the entire press. To remove power to the press, turn the disconnect handle to the Off position. The disconnect handle should be turned off when the press is not in use.



	 WARNING
	<p>Always turn off power at the main power source before opening the electrical enclosure.</p> <p>Even when the disconnect switch is turned to the Off position, there is still live power to the enclosure where the disconnect switch is mounted. This live power may cause severe electric shock.</p>

Figure 4-2: Disconnect Switch Location



Indicators on the Press

Main Beacon

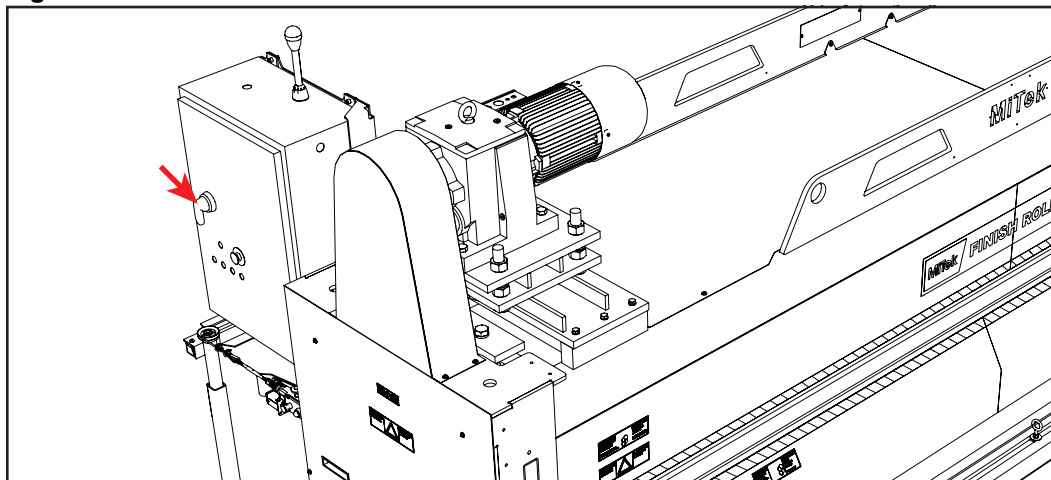
The main beacon displays different colors depending on the state of the press. The main beacon is located on top of the electrical enclosure as shown in Figure 4-3.

Table 4-1: Main Beacon Lights

Color	State of Press
Red	E-stop triggered or VFD experiencing a fault
Yellow	Motor running
Green	Ready to operate

Figure 4-3: Main Beacon Location

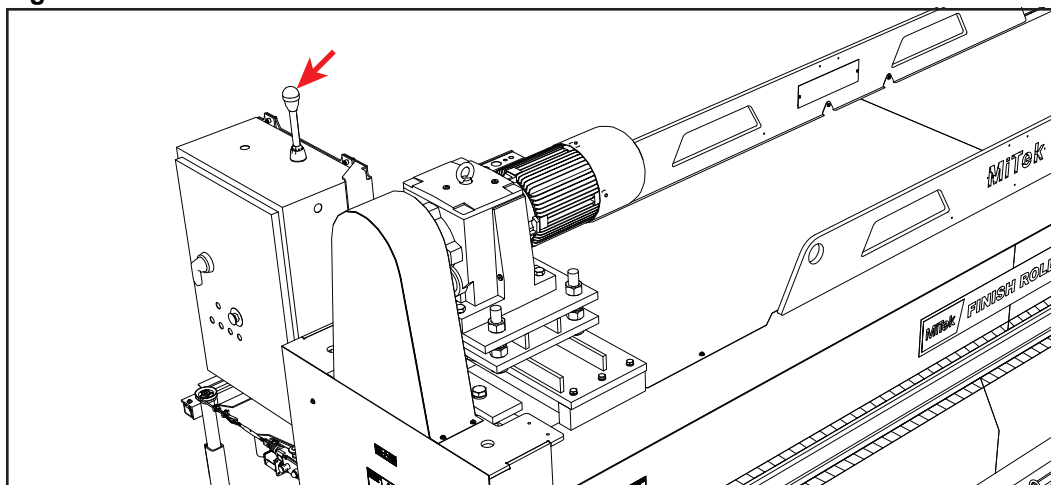

E-Stop Pushbuttons

The E-stop pushbuttons located on the main electrical enclosure and the pull-cord switches indicate when they are pressed.

Figure 4-4: E-Stop Pushbutton Indicator Locations

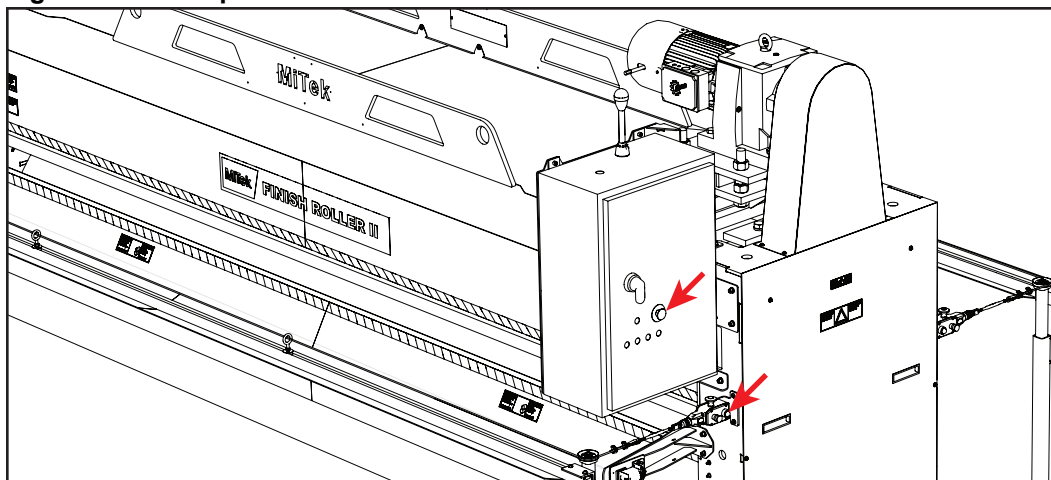

Horn

The horn sounds when a truss passes through the press. The horn is located on the underside of the electrical enclosure.

Figure 4-5: Horn Location

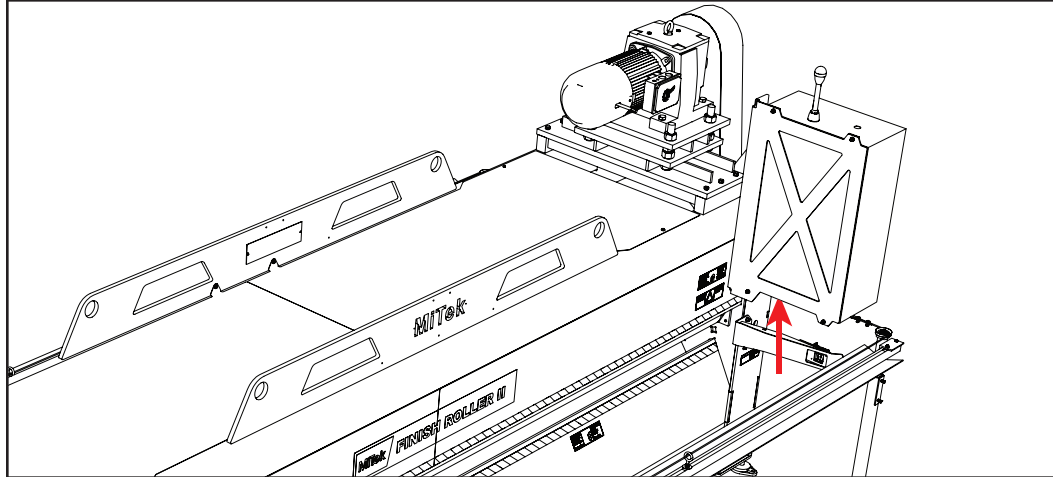

Indicators on Optional Light Curtains

Light Curtain Beacon

Light curtains are included with presses that are used with end-eject systems. If a person passes through the light curtain, the light curtain triggers an E-stop. The light curtain is not affected by a gantry head moving through it. The beacon on the light curtain transmitter stand indicates the state of the light curtain.

Table 4-2: Light Curtain Beacon

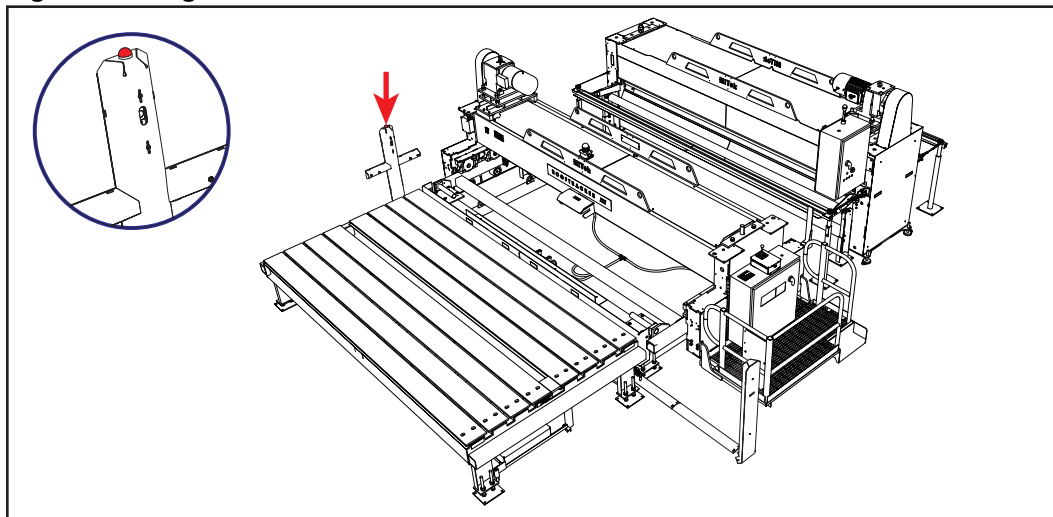

Color	State of Light Curtain
Red	Experiencing a E-stop
Green	Ready to operate

Figure 4-6: Light Curtain Beacon Location



Operating the Press

The press operates in two modes. In manual mode, the press rollers turn continuously. In automatic mode, the press rollers turn only when the photoelectric sensor detects a truss.

	 WARNING
	<p>Trusses should enter the press directly from the adjacent conveyor. Do NOT feed trusses by hand into the press.</p> <p>Feeding trusses by hand into the press may result in serious physical injury or death.</p>

Operating the Press

1. Turn the disconnect switch handle to the On position.

Figure 4-7: Turning the Disconnect Switch to the On Position

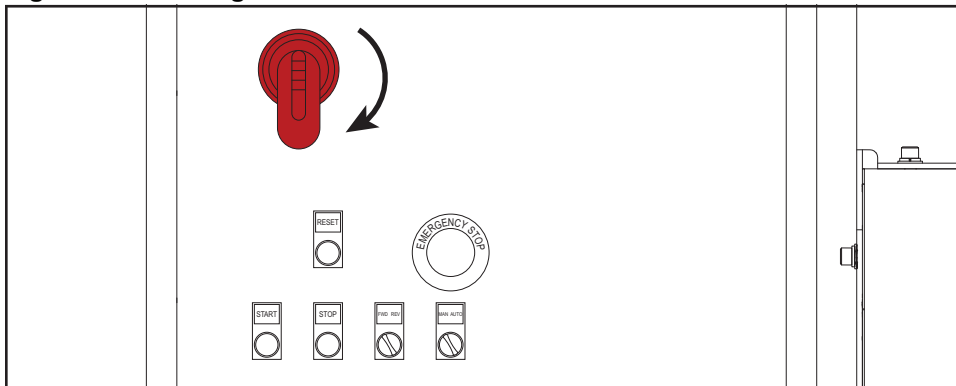

2. Press the Reset button and hold for one second to reset the safety circuit and prepare the press to run.

Figure 4-8: Pressing Reset Button

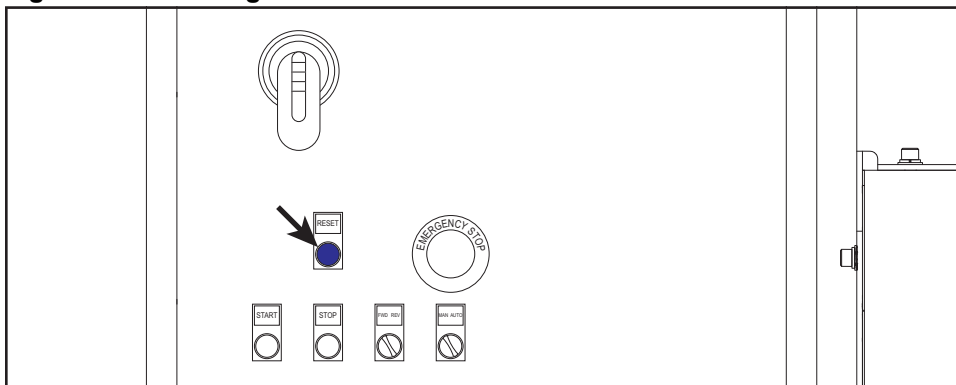

3. Continue based on the mode in which you want to operate the press.
 - To run the press continuously (manual mode), see page 79.
 - To run the press only when a truss is present (automatic mode), see page 80.

Operating the Press in Manual Mode

Use the controls on the electrical enclosure to operate the press in manual mode. See Figure 4-9 for the controls referenced in Table 4-3.

Figure 4-9: Controls Used in Manual Mode

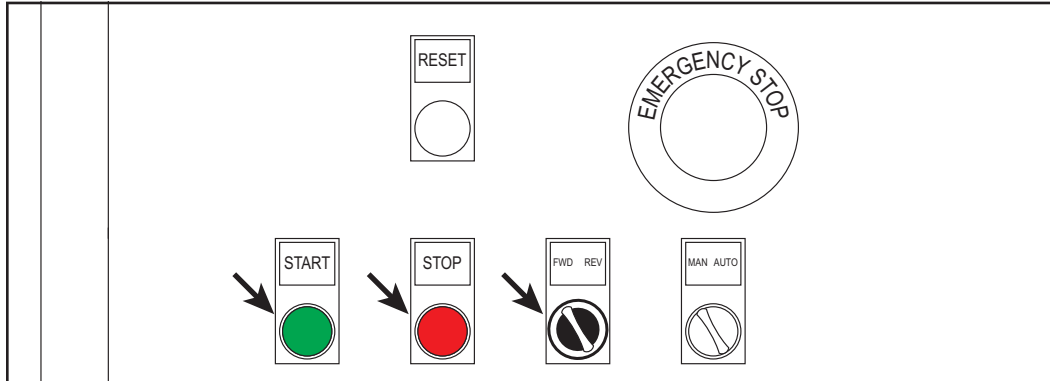

Table 4-3: Operating the Press in Manual Mode

Operation	Actions
Run the press normally	Press and hold Start until the Start button illuminates and the press runs.
Stop the press normally while running in forward	Press Stop .
Run the press in reverse	Turn and hold the directional selector switch to REV. Press and hold Start until the button illuminates and the press runs.
Stop the press normally while running in reverse	Press Stop or release the directional selector switch to stop the rollers from turning. Always use this method for normal (non-emergency) stopping.
Stop the press in an emergency	Press an E-stop pushbutton or pull one of the pull-cords. See page 73 for more details. Use this method only in emergency situations to avoid premature wear and tear on the components.

See page 76 for an explanation of the lights on the beacon.

Operating the Press in Automatic Mode

Use the controls on the electrical enclosure to run the press in automatic mode. In automatic mode, the press runs only when its photoelectric sensor detects a truss, sounds the horn, and signals the VFD to start the rollers. See Figure 4-10 for controls referenced in Table 4-4.

Figure 4-10: Controls Used in Automatic Mode

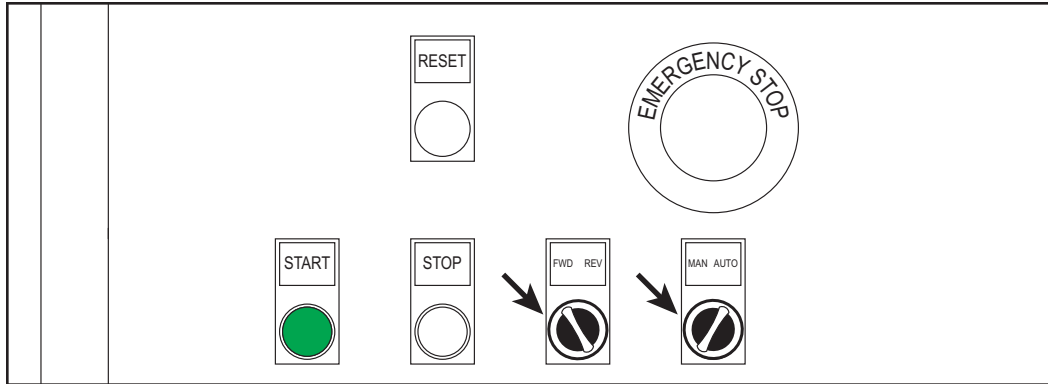

Table 4-4: Operating the Press in Automatic Mode

Operation	Actions
Run the press in automatic mode	Turn the automatic selector switch to AUTO. Press Start until the button illuminates.
Stop operating in automatic mode	Press Stop . Always use this method for normal (non-emergency) stopping.
Stop operating in automatic mode	Turn the automatic selector switch to MAN.
Stop the press in an emergency	Press an E-stop pushbutton or pull one of the pull-cords. See page 73 for more details. Use this method only in emergency situations to avoid premature wear and tear on the components.

See page 76 for an explanation of the lights on the beacon.

Maintenance

**Purpose
of Chapter**

This chapter provides step-by-step instructions and other information to help you make repairs and perform preventative maintenance.

Content Overview

Introduction to Maintaining Your Press	82
Preventive Maintenance & Parts	82
Performing Maintenance Safely	83
Before Operating This Machine	83
Lockout/Tagout	84
Important Safety Information	84
Making Adjustments and Replacing Parts	86
Wearing Personal Protective Equipment	87
Testing the Safety of the Machine	87
Cleaning the Press	87
Maintaining the Mechanical System	88
Gearmotor	88
Chains and Sprockets	93
Bearings and Rollers	100
Electrical System	106
Electrical Enclosure	106
Photoelectric Sensor	106
Pull-Cord	108
Light Curtain	110
VFD (Variable Frequency Drive)	114
Safety Controller	114

Introduction to Maintaining Your Press

This manual contains sufficient information for proper maintenance under most conditions. Certain environments may require preventative maintenance more frequently.

Review the table of contents and utilize the index to locate the information that you need. The following appendices also assist in maintaining and repairing your machine.

- Troubleshooting
- Parts List
- Maintenance Checklists
- Drawing Set

Read the *Performing Maintenance Safely* section before beginning maintenance on this machine.

	NOTICE
	<p>This icon is an important safety note.</p> <p>It indicates that you must lockout/tagout at the appropriate disconnect switch using approved methods described in OSHA CFR 1910.147 before continuing with the procedure.</p>

Preventive Maintenance & Parts

Refer to the *Maintenance Checklist* appendix for a schedule of all preventive maintenance.



Because consistent preventative maintenance is so important for keeping your machine in good operating condition, MiTek recommends that you stock certain replacement parts to minimize downtime. See the *Parts List* appendix, starting on page 124.



Performing Maintenance Safely



Read the safety section starting on page 1, and adhere to all rules and guidelines. This section provides additional safety information specific to maintenance topics.

Before Operating This Machine

Review these warnings before operating this machine.

	 WARNING
	<p>ELECTROCUTION AND CRUSH HAZARDS</p> <p>Read this section AND the safety section in the preliminary pages before operating or maintaining this equipment.</p> <p>Do not operate this machine until you have a thorough understanding of all controls, safety devices, E-stops, and operating procedures outlined in this manual.</p> <p>Read and observe all hazard instructions. Failure to do so may result in economic loss, property damage, and/or personal injury.</p> <p>This manual must always be available to personnel operating and maintaining this equipment.</p>



	 WARNING
	<p>CRUSH HAZARD</p> <p>Guards must always be in place during operation to avoid serious injury and possibly death.</p> <p>Always replace guards after completing maintenance and before removing the lockout/tagout device.</p>

	 WARNING
	<p>CRUSH HAZARD.</p> <p>Before turning on the equipment, make sure that all personnel and equipment are clear.</p>

Lockout/Tagout

The lock and tag symbol shown here indicates that proper lockout/tagout procedures must be used prior to starting the procedure where the symbol occurs.



	 WARNING
	<p>ELECTROCUTION AND HIGH PRESSURE HAZARDS</p> <p>Always turn the power off by activating an E-stop when the equipment is not in operation.</p> <p>Always verify that all power to the machine has been turned off and follow approved lockout/tagout safety procedures (OSHA 29 CFR 1910.147) before performing any maintenance on this equipment.</p> <p>If it is absolutely necessary to troubleshoot an energized machine, follow NFPA 70E or the governing regulations at your location for proper procedures and personal protective equipment.</p> <p>The components on this machine can cause severe injury if adjusted improperly. Follow all procedures in this manual and do not make adjustments to the machine without guidance from MiTek or MiTek documentation.</p> <p>Only trained personnel should make adjustments to this machine.</p>

Important Safety Information



Your Responsibilities

Detailed descriptions of standard workshop procedures, safety principles, and service operations are not included in this manual. Although this manual contains some warnings and cautions against specific service methods which could cause personal injury or damage to the machine, it does not cover all conceivable ways of service which might be done or the possibility of hazardous consequences of each conceivable way. If you intend to handle, operate, or service the unit by a procedure or method not specifically recommended by the manufacturer, first make sure that such a procedure or method will not render this equipment unsafe or pose a threat to you and others.

It is the responsibility of the mechanic performing the maintenance or service on a particular machine to:

1. Inspect the machine for abnormal wear and damage;
2. Choose a procedure which will not endanger his or her safety, the safety of others, the equipment, or the safe operation of the machine;
3. Fully inspect and test the machine and the mechanical and electrical systems to ensure that the service to the machine has been properly performed and that the machine, mechanical, and electrical systems will function properly; and

4. Ensure only qualified electricians perform electrical service work.

 WARNING	
	This machine uses high-voltage electricity, which may cause serious personal injury or death.

General Service Rules

1. The design may change or upgrades may occur for any particular component. Always contact the factory before replacing components.
2. If inspection or testing reveals evidence of abnormal wear or damage to the machine or if you encounter circumstances not covered in the equipment manual—STOP—and consult MiTek. The machine must be repaired and serviced according to the current specifications and procedures of MiTek, using replacement parts with properties equal to or greater than those specified by MiTek.
3. Use the correct tools and procedures on this machine, to avoid damage and incorrect assembly.

NOTICE	
	Never use compressed air inside an electrical enclosure. It may force contaminants into electrical connections. Use a vacuum to remove dust from electrical enclosures. Canned air is acceptable after vacuuming.



4. Always install new gaskets, O-rings, cotter pins, etc., and place Loctite on bolts, if required.
5. Torque bolts and fasteners to the correct specifications.
6. Clean parts in a nonflammable or high-flash-point solvent only.
7. Lubricate any sliding surfaces before assembly.
8. Many components are manufactured from high carbon, heat-treated steel. Do not attempt to straighten, bend, or weld these components, as they may fail under load causing serious personal injury or death.
9. After re-assembly, check all parts for proper installation and operation before putting the machine back into service.
10. It is beneficial to record all major maintenance and testing. This allows recurring problems to be predicted and addressed before any production time is lost. Typical reports and records should include:
 - Date
 - Serial number of machine

- Description of problems or symptoms
- Corrective action taken
- Parts required

11. MiTek will, from time to time, mail out service bulletins and updates for this machine. Follow the service bulletins and updates accordingly and file them in this equipment manual.

Making Adjustments and Replacing Parts



Be careful when making mechanical adjustments. Untrained personnel may damage the machine or cause harm to themselves and others.

	 WARNING
	<p>CRUSH HAZARDS</p> <p>Always replace guards after servicing.</p> <p>Only qualified maintenance personnel shall repair, remove, or replace guards and safety devices.</p>

	NOTICE
	<p>Failure to follow the step-by-step procedures in this chapter may result in incorrect adjustment of this machine.</p> <p>Only trained maintenance personnel should make adjustments to this machine.</p> <p>Use only the exact replacement parts specified in this manual.</p>

Special materials have been used for some of the components of this equipment. It is critical to the future performance of this machine that only specified replacement parts are used. Order all replacement parts through MiTek. Do not substitute parts without first consulting MiTek to determine if it is safe and effective. No electrical system component, cable, connector, or device should be modified, removed, disconnected, changed without specific approval and guidance from MiTek.

Wearing Personal Protective Equipment

	 CAUTION
	<p>Follow OSHA guidelines to utilize the proper personal protective equipment (PPE) while performing maintenance.</p> <p>The most common include eye protection, hearing protection, dust masks while blowing off sawdust, gloves while working with solvents, and fire retardant clothing when troubleshooting an energized machine.</p>



Testing the Safety of the Machine

The test procedure in the *Safety* section starting on page 10 MUST be performed by qualified personnel after ANY maintenance, adjustment, or modification.

Testing makes sure that the safety system and machine control system work together to stop the gantry head properly. The test should be performed before each shift starts to make sure that the safety features remain in working order.

Cleaning the Press

If it should become necessary to clean this machine, disconnect it from its power source first. Do not use liquid cleaners, aerosols, abrasive pads, scouring powders or solvents, such as benzene or alcohol. Use a soft cloth lightly moistened with a mild detergent solution. Make sure the surface cleaned is fully dry before reconnecting power.

	 CAUTION
	<p>CRUSH HAZARD</p> <p>Always replace guards after completing maintenance and before removing the lockout/tagout device.</p> <p>Operating a machine with guards removed may result in serious injury or death.</p>

Maintaining the Mechanical System

Gearmotor

Changing the Rotation of a Motor

All motors are 3-phase motors. If the motor is rotating in the wrong direction, lockout/tagout the Finish Roller II and swap any 2 of the 3-phase wires.

Manually Releasing an Electric Brake

Push the manual brake lever away from the gearbox on the motor to release the brake manually. See Figure 5-1. The manual brake lever springs back to its engaged position when it is no longer pushed.

Figure 5-1: Manual Brake Lever

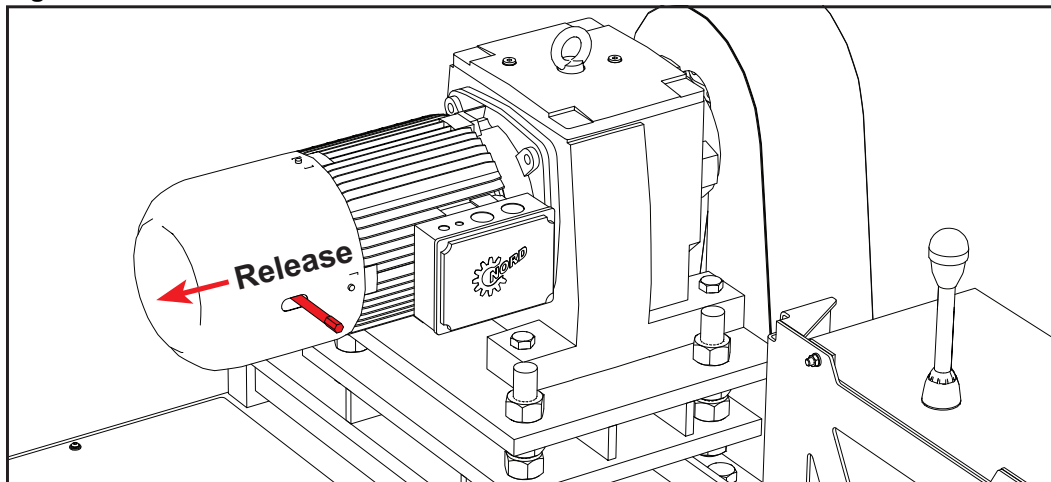

Verifying Tightness of Motor Mount Nuts

Verify that the nuts that hold the gearbox to the mount and the nuts that hold the mount together are tight every month (one shift) or two weeks (two shifts).

Figure 5-2: Motor Mount Nut Locations

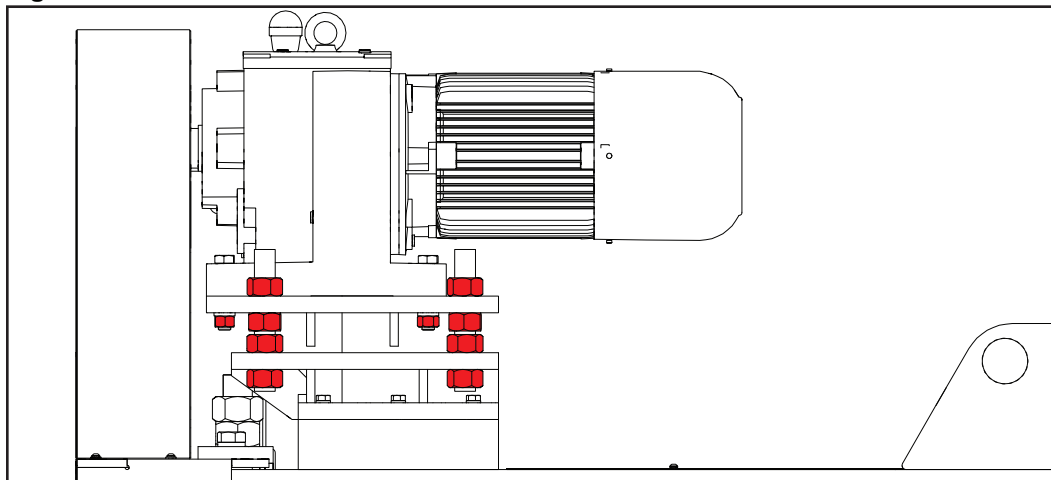

Standard wrench set



Lubricating the Gearbox

Preventative maintenance is required to keep the gearmotor working and to prevent costly replacement of the gearmotor.

Check the oil in the gearbox once every month (one shift) or two weeks (two shifts). When additional oil is needed, use the oil recommended in Table 5-1 or a comparable type.

Table 5-1: Oil Used by the Manufacturer

Attribute	Standard
ISO viscosity	VG220
Oil type	Mineral oil with extreme pressure additive
Ambient temperature range*	30° to 104° Fahrenheit (0° to 40° Celsius)
Manufacturer / type**	Mobil / Mobilgear 600XP220

* If a different temperature range is required, a different oil may be selected, as long as it has the same properties as the oils listed here.

** The manufacturer recommends Shell Omala S2 G 220 and Castrol Alpha SP220 as well.

Drain and refill the oil every twenty-four months (one shift) or twelve months (two shifts). The oil drain bolt is a socket-head cap screw located underneath the drive shaft.

The approximate amount of oil used to fill the gearbox is listed in Table 5-2. This amount of oil should be enough to reach the oil level bolt. The oil level bolt is a socket-head cap screw to the right of the drive shaft. See Figure 5-3.

Table 5-2: Approximate Oil Fill Level

Quarts	Liters
9.0	8.5

Figure 5-3: Oil Level Bolt and Oil Drain Bolt

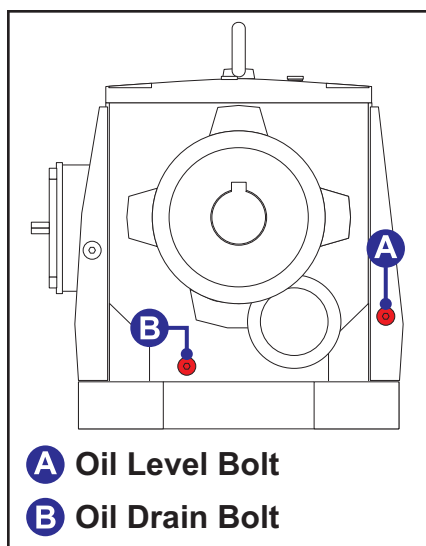

Shaft side of gearmotor

Replacing a Brake Pad

1. Lockout/tagout the Finish Roller II.
2. Unscrew the manual brake handle extending from the side of the brake motor, if there is one.
3. Remove the fan cover. The fan cover is attached to the motor end shield.
4. Remove the fan snap ring.
5. Remove the fan, key, and second snap ring.
6. Remove the three socket head cap screws that hold the brake onto the motor end shield.
7. Slide the brake off of the brake hub. The hub is attached to the shaft.
8. Slide the new brake pad onto the brake hub.
9. Place the brake on the motor end shield in the same manner as it was removed.
10. After the three socket head cap screws are tightened, measure the air gap for proper distance. The procedure for measuring and adjusting the air gap is described on page 91.
11. Replace the fan, snap rings, and key. Then replace the fan cover.
12. Remove the lock and tag. Then resume operation.

Figure 5-4: Brake and Brake Pad

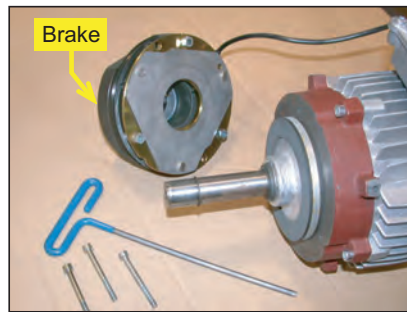

Figure 5-5: Removing the Brake Pad

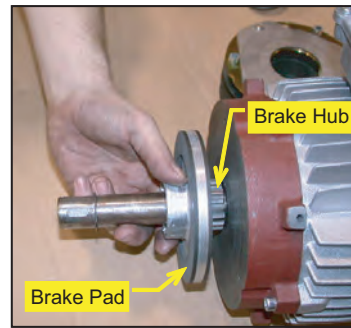



Figure 5-6: Fan and Fan Cover



- Slotted and Phillips screwdrivers
- External snap ring pliers
- Metric wrench set
- Metric socket wrench set

Adjusting the Air Gap

 WARNING	
	Do NOT attempt adjustment unless the air gap is outside of the recommended specification.
	Adjusting the air gap improperly may affect the stopping of the Finish Roller II.
	If the Finish Roller II fails to stop as anticipated, serious injury or death may occur.

Air Gap Specifications

If the brake monitor continually trips and other causes have been eliminated, you may need to adjust the air gap. Specifications for the air gap are as follows:

- The nominal air gap setting is 0.016" (with a tolerance of + 0.004"). The air gap should be set within this range from the factory.
- The maximum air gap setting is 0.043".

Adjusting the Air Gap

1. Lockout/tagout on the Finish Roller II.
2. Unscrew the manual brake handle from the side of the brake motor, if there is one
3. Remove the fan cover.
4. Using a feeler gauge, measure the gap between the armature disk and brake housing, shown in Figure 5-7. Measure completely around the brake and record any variations in measurement.

Figure 5-7: Measuring the Air Gap

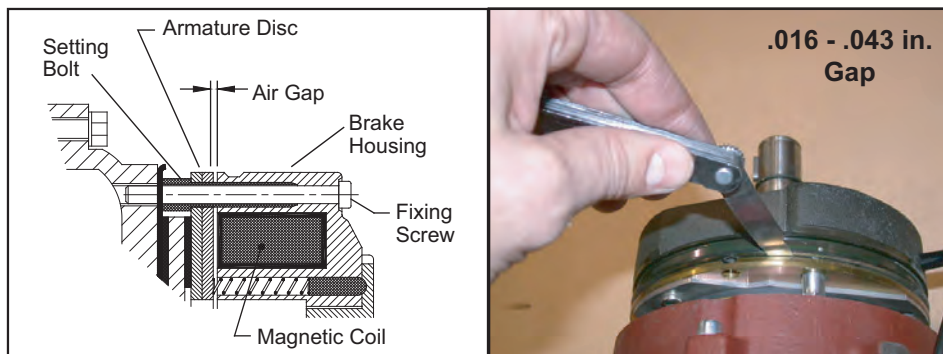

5. If the measurements are outside of specifications, adjust the air gap using the following steps:
 - a) Remove the fan snap ring.
 - b) Remove the fan, key, and second snap ring.
 - c) Loosen the fixing screws that attach the brake to the motor's end shield by about half a turn.



Feeler gauges

External snap ring pliers

Slotted and Phillips screwdrivers

Metric combination wrench set

Metric socket wrench set

Torque wrench capable of 18 ft-lbs (24.4 Nm)

- d) Adjust the setting bolts as needed to reach the recommended gap. A 1/4 or 1/2 turn is usually sufficient. See Figure 5-8.

Figure 5-8: Adjusting the Setting Bolts

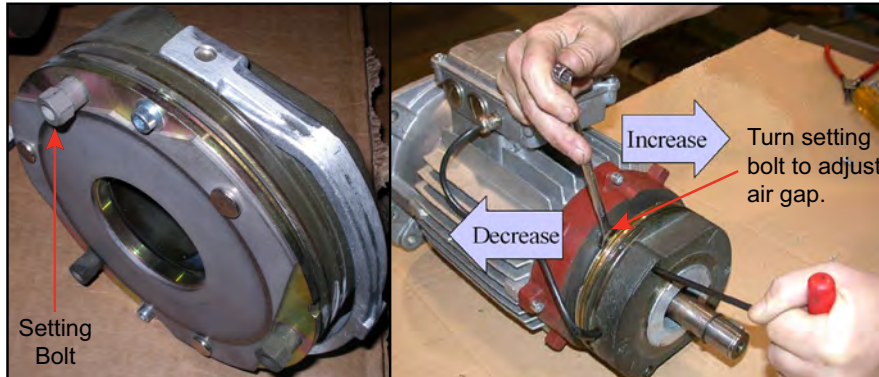

- 6. Check the air gap again to make sure it is within specification. It may be necessary to adjust a setting bolt more than once because other bolts may affect one another's position.



The air gap must be uniform on each side.

- 7. Torque all of the fixing screws to 18 ft-lbs (24.4 Nm).
- 8. Re-attach the fan, snap rings, key, fan cover, and handle.
- 9. Remove the lock and tag. Restore power and resume operation.

Chains and Sprockets

Lubricating Chains

The drive and idler chains need lubrication every month (one shift) or two weeks (two shifts). Chain locations are highlighted in Figure 5-9.

The lubricant should be a high-grade, non-detergent, petroleum-base oil. Anti-foam, anti-rust, and film-strength improving additives are often beneficial. SAE 30 grade is recommended.

Figure 5-9: Chain Locations

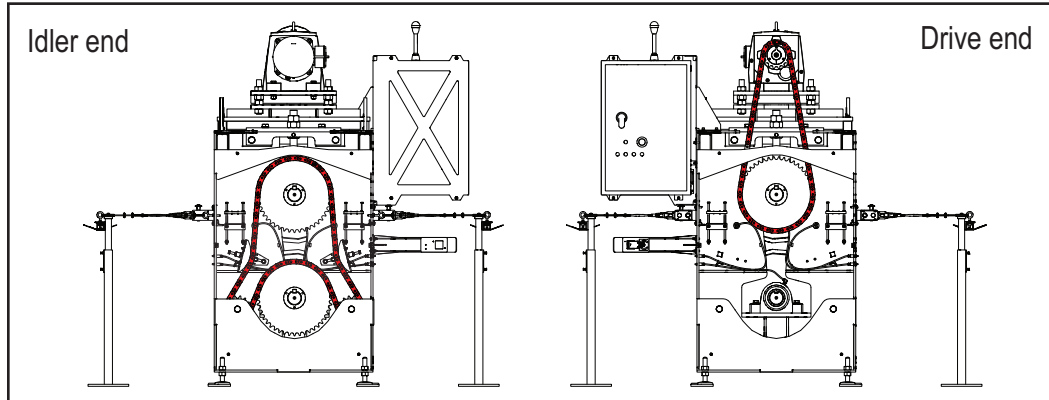

Guards removed for clarity

Replacing a Chain

To replace a chain, reduce chain tension according to the instructions starting on page 94. Remove the cotter pins from the master link, shown in the detail of Figure 5-10. Pull the master link apart to remove it. Remove the chain from its sprockets. Route the new chain around the sprockets as shown in Figure 5-10 and replace the master link. Tension the chains according to the instructions starting on page 94.

Figure 5-10: Chain Routing

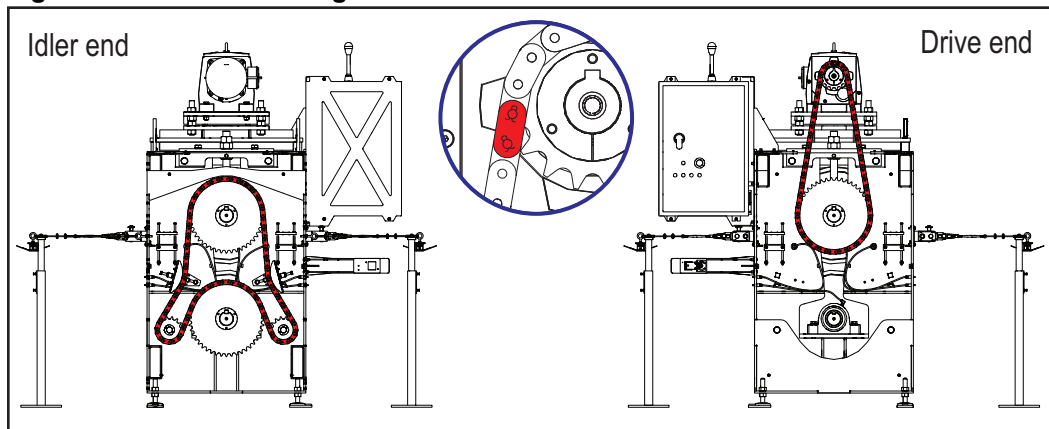

Guards and parts of frame removed for clarity



- Oil
- Brush
- Clean rag
- Standard hex key set



- Standard hex key set
- Pliers

Tensioning the Drive Chain

The motor mount plate, shown in red in Figure 5-11, moves the gearmotor and small drive sprocket up and down to adjust drive chain tension. Halfway between the small drive sprocket and large drive sprocket, the drive chain should have a 1/2" of play.

The drive chain may lose tension over time. Check the drive chain tension every week. If the chain is not tensioned properly, adjust the motor mount plate using the nuts on the threaded rods. Make sure that the motor mount plate is level after adjustment.

Figure 5-11: Drive Chain Tension Adjustment

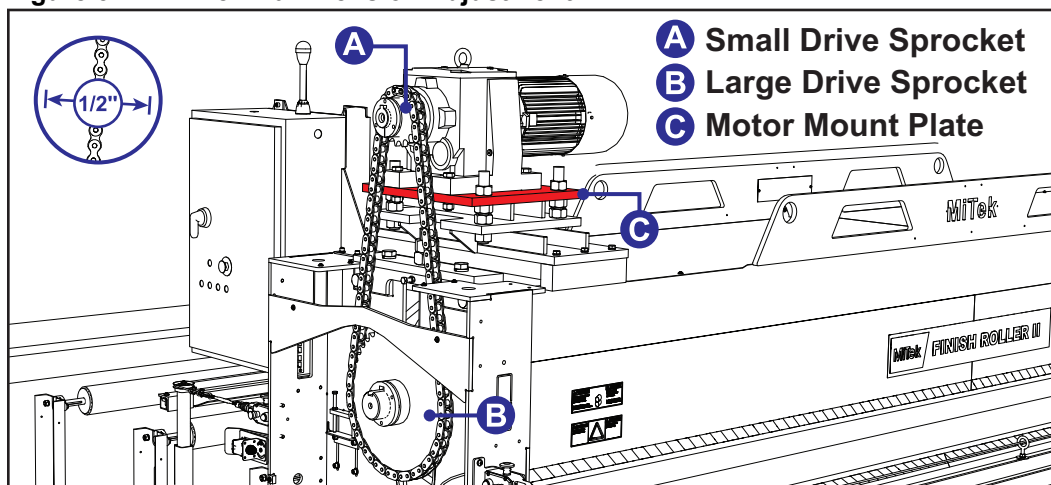

- A** Small Drive Sprocket
- B** Large Drive Sprocket
- C** Motor Mount Plate



1-7/8" wrench

Level

Standard hex key set

Tensioning the Idler Chain

The idler chain tensioners and brackets, shown in red in Figure 5-12, move in and out to adjust idler chain tension. Halfway between the chain tensioner and the top large sprocket, the idler chain should have 1/4" of play.

The idler chain may lose tension over time. Check the idler chain tension every week. If the chain is not tensioned properly, loosen the screws on the chain tensioner bracket and loosen the jam nuts. Use the adjustment screws to adjust the chain tensioners. Adjust both tensioners equally.

Figure 5-12: Idler Chain Tension Adjustment

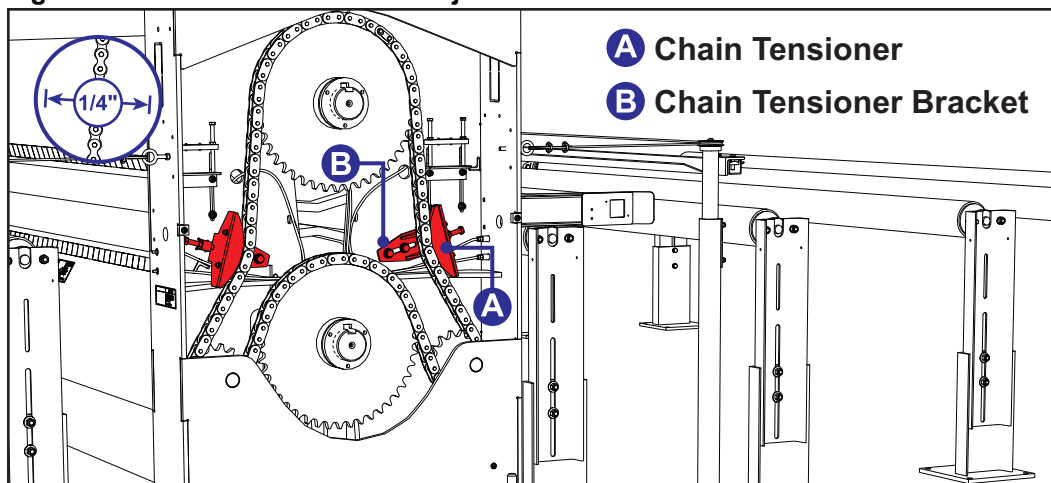

- A** Chain Tensioner
- B** Chain Tensioner Bracket



Standard hex key set

Standard combination wrench set

Standard socket wrench set with extension

Replacing a Chain Tensioner

The chain tensioners wear over time. To replace a chain tensioner, loosen the screws fastening the chain tensioner bracket to the frame and move the bracket to slack the chain. Then remove the two screws fastening the chain tensioner to the bracket and replace the chain tensioner. Make sure the tensioner is centered on the chain rollers. After replacement, tension the chain according to the applicable instructions on page 94.



Figure 5-13: Chain Tension Removal and Replacement

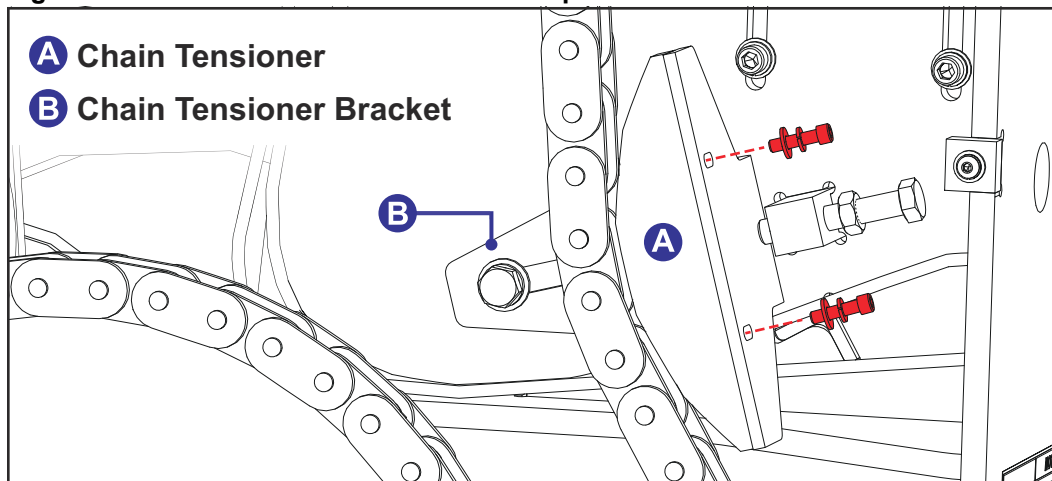

Standard hex key set

Standard socket wrench set with extension

Checking Split Collars and Small Idler Sprocket Set Screws

The small idler sprockets have set screws to keep them in place on their shafts. The small idler sprocket shafts have split collars to keep the shafts from moving. Tighten the screws on both the idler sprockets and the split collars every two months (one shift) or one month (two shifts).



Figure 5-14: Split Collar Location

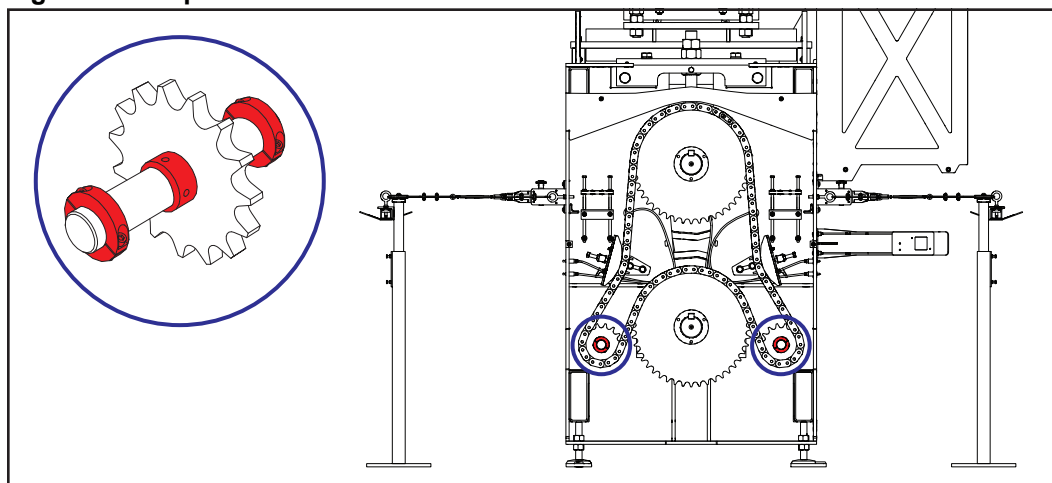

Standard hex key set

Replacing a Large Sprocket

The large sprockets use QD (quick disconnect) bushings to connect them to the shafts of the press rollers. To replace a large sprocket, use the following steps:

1. Lockout/tagout on the electrical enclosure.
2. Prepare the press for removal of the sprocket by using the following steps:
 - a) Remove the guards that cover the sprocket and chain. All drive chain and end guards are shown removed in Figure 5-15.

Figure 5-15: Removing Drive Chain Guard and End Guards

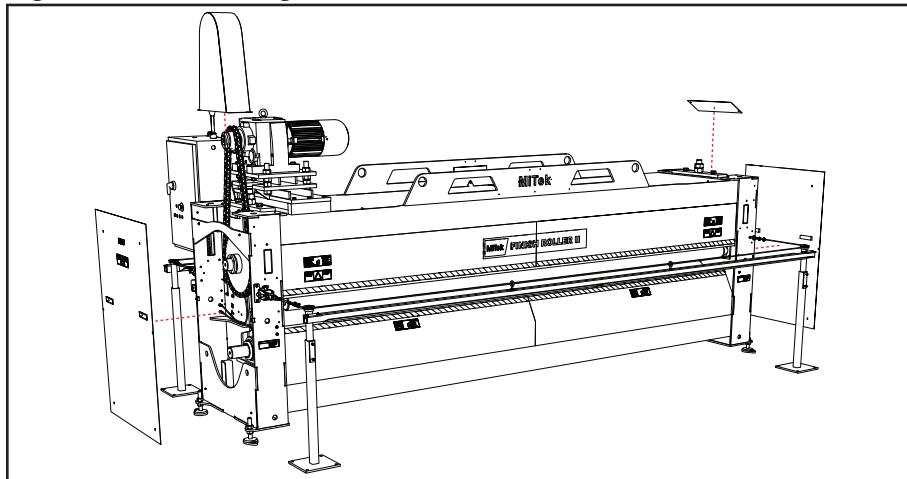

- b) Remove the master link and remove the chain. If necessary, see page 93 for additional information about removing the chain.
3. Remove the sprocket by using the following steps:
 - a) Remove the set screw that holds the key in place from the QD bushing.

Figure 5-16: QD Bushing Set Screw Location

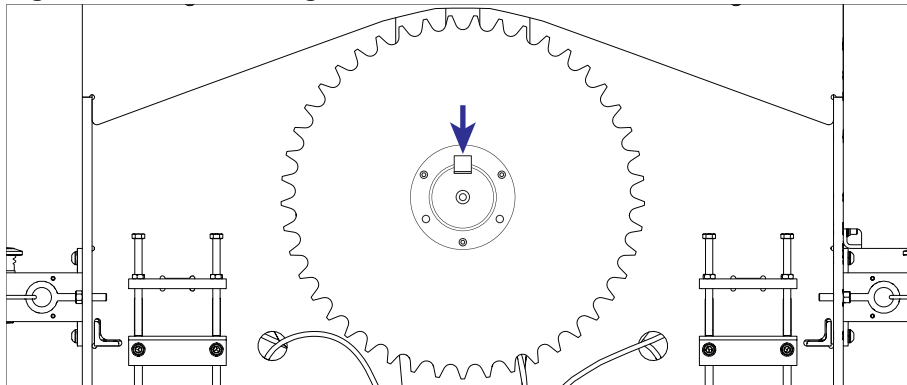

Standard hex key set

Torque wrench capable of 29 ft-lbs (39.3 Nm) of torque

Pliers

Rubber mallet

- b) Remove the three screws from their locking holes on the QD bushing by turning each screw a full turn at a time and then moving to the next screw in a counterclockwise pattern.

Figure 6: Removing Screws from the QD Bushing

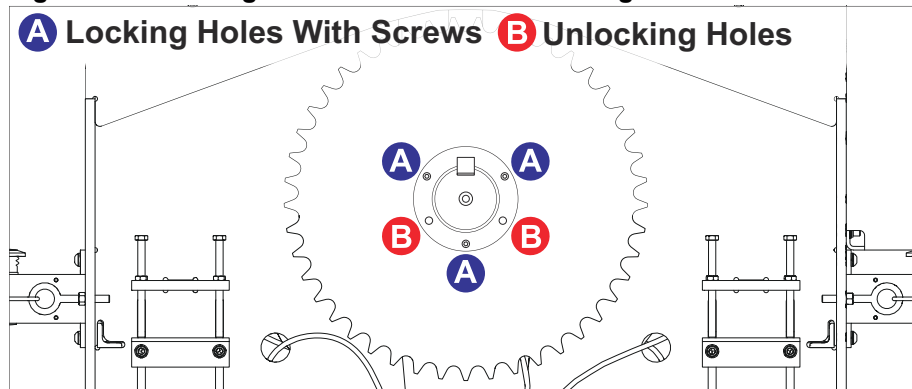

- c) Place two screws into the unlocking holes.

Figure 5-1: Placing Screws into Unlocking Holes

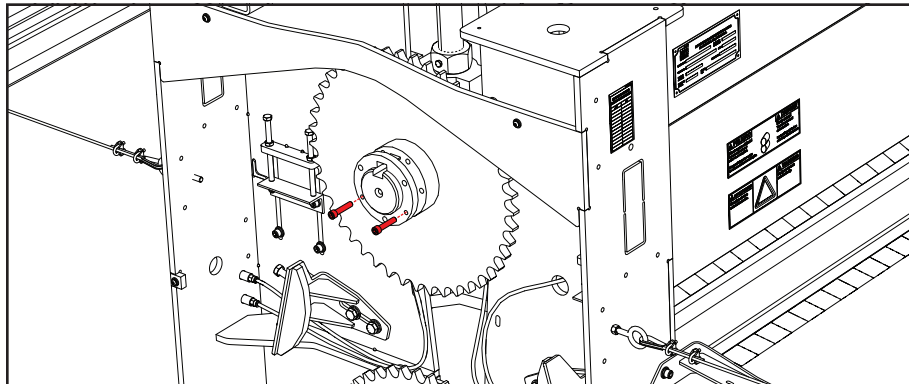

- d) Separate the bushing from the sprocket by turning each screw a full turn, tapping the sprocket above the keyway with a rubber mallet, and then repeating until the bushing and sprocket are separated. Save the bushing and key for reuse.

Keep the axis of the sprocket bore parallel with the axis of the shaft.

- e) Remove the bushing, key, and sprocket from the drive shaft.

Figure 5-2: Bushing, Key, and Sprocket Removed

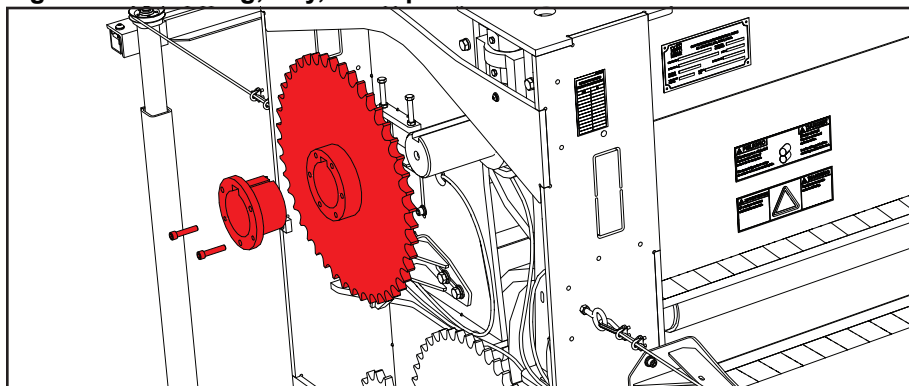

4. Place the new sprocket and bushing by using the following steps:
 - a) Place the new sprocket onto the drive shaft with the keyway at the top.

Figure 5-3: Sprocket Placement

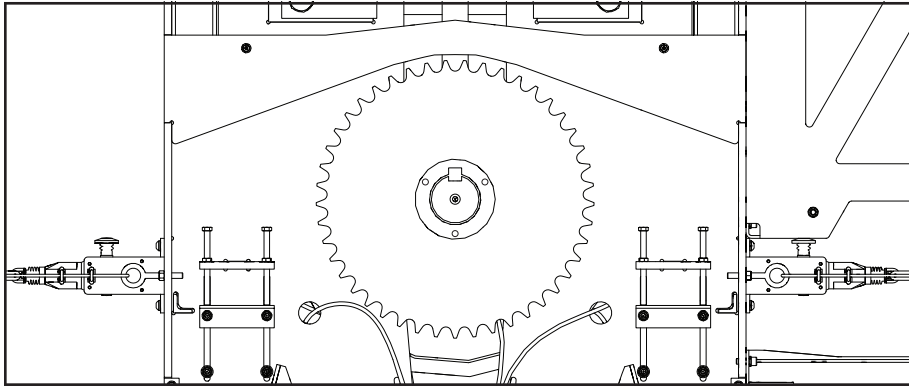

- b) Place the bushing onto the drive shaft and into the sprocket bore.
 - c) Place the key in the keyway.
5. Tighten the sprocket and bushing by using the following steps.
 - a) Insert the original screws through the locking holes of the bushing so that they enter the threads in the sprocket. Hand tighten the screws in the locking holes.

Figure 5-4: Screws Inserted in Locking Holes

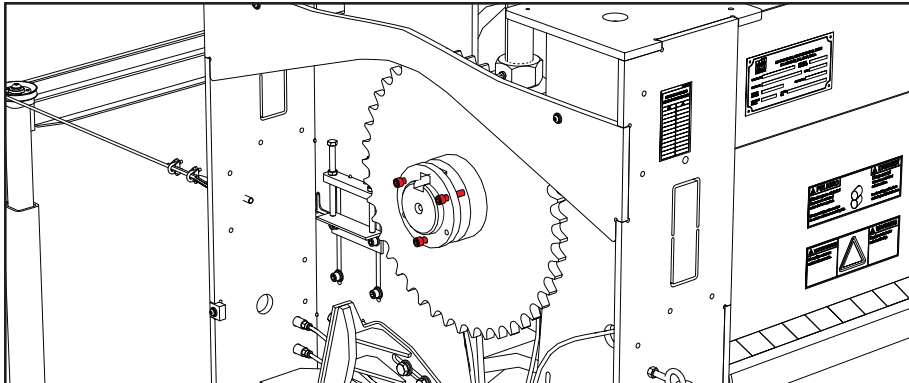

- b) Move the sprocket and bushing so that the sprocket is 1/8" to 1/16" deeper than the other sprocket(s) on that side of the press.

- c) Tighten the screw in the first position, shown in Figure 5-5, a full turn. Then move to the next screw and repeat. Move clockwise around the screws until each screw reaches 29 ft-lbs (39.3 Nm) of torque.

As you tighten the bushing, the sprocket should move forward so that its face is the same depth as the other sprocket face(s).

Figure 5-5: Screw Tightening Pattern

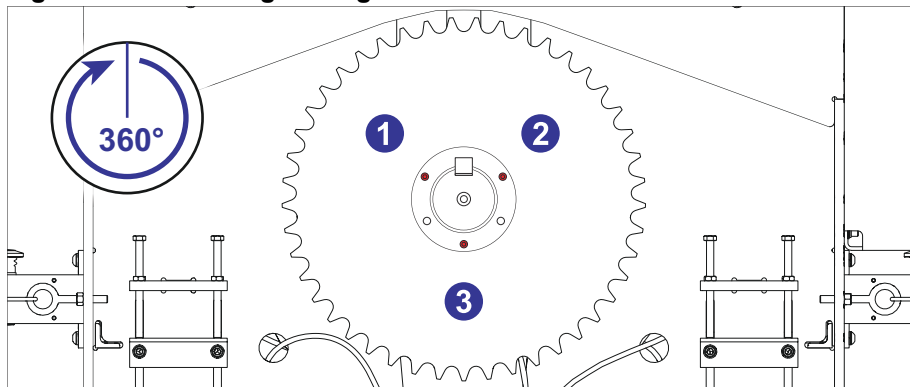

- d) Check torque on the three screws a final time to make sure they do not move.
- e) Insert the set screw above the key and tighten it.
- f) Make sure that the sprockets are aligned as shown in Figure 5-6.
If the sprockets are not aligned, remove the bushing and sprocket and reinstall it.

Figure 5-6: Sprocket Alignment

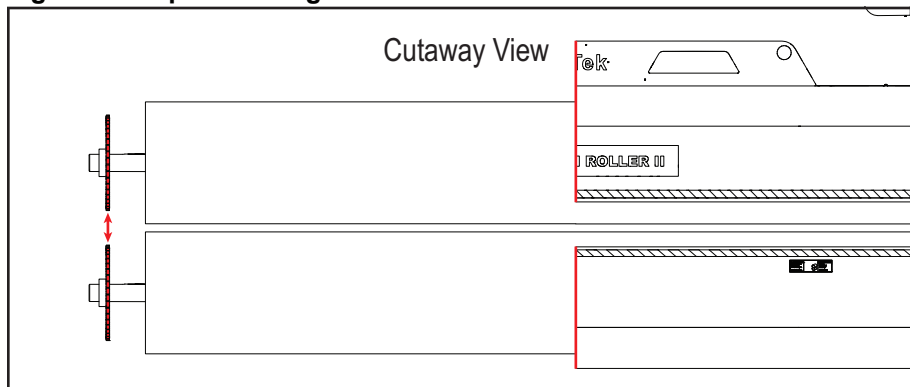

- 6. Prepare the press for operation by using the following steps:
 - a) Place the chain back onto the sprockets. If necessary, see page 93 for additional detail about routing the chain.
 - b) Tension the chain according to the applicable instructions on page 94.
 - c) Place the guards back onto the press.
 - d) Remove the lock and tag.
- 7. Resume operation.

Bearings and Rollers

Lubricating Bearings

The bearings that hold the press rollers and guide rollers need grease every twelve months (one shift) or six months (two shifts). Use a grease that matches the specifications in Table 5-3.

Table 5-3: Grease for Bearings

Specification	Technical Data
Type	Lithium
NLGI grade	2

1. Lockout/tagout on the disconnect switch on the electrical enclosure.
2. Locate two grease zerk fittings on an end of the press. See Figure 5-7.

Figure 5-7: Grease Zerk Fittings for Bearings

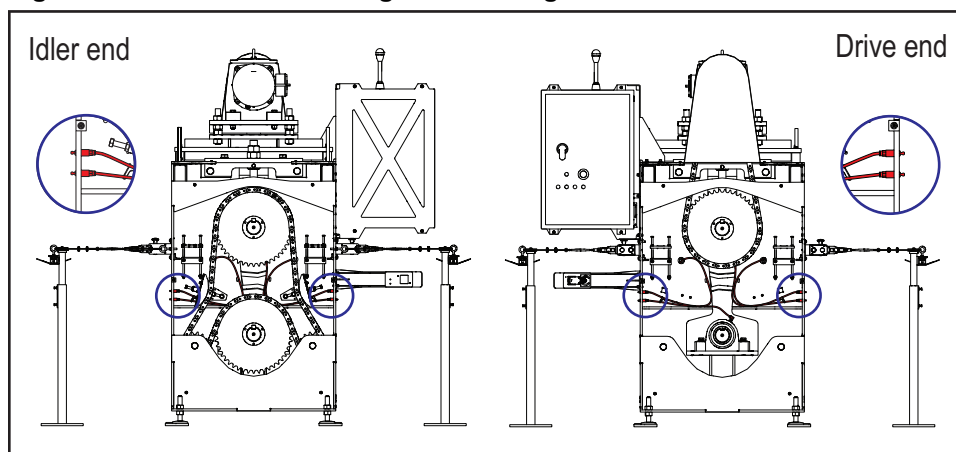

Guards removed for clarity

3. Use the grease gun to add grease to the bearings. Pump until you feel resistance. Do not over grease.
4. Wipe the excess grease from the zerk fittings.
5. Repeat for the remaining zerk fittings.
There are a total of eight zerk fittings on the press.
6. Remove the lock and tag. Restore power. Resume operation.



Grease gun

Clean rag

Grease specified in Table 5-3

Adjusting Guide Rollers

The guide rollers are idler rollers that adjust vertically. The guide rollers are adjusted at the factory and should not require adjustment under normal operation. If you need to adjust the guide rollers, use the following steps:

1. Use the manual controls to feed two 16' 2x4 boards into each end of the press and stop the press when the 2x4s are halfway through the press. See Figure 5-8.

Figure 5-8: Positioning 2x4s

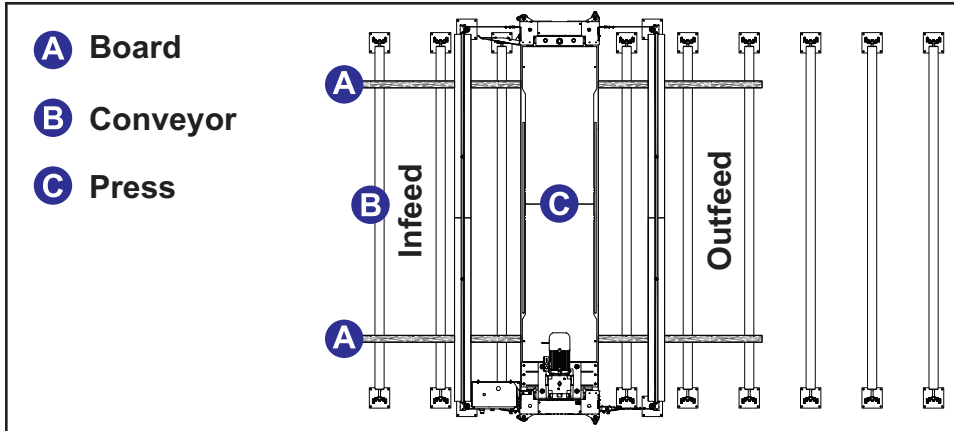

2. Lockout/tagout on the electrical enclosure.
3. Remove the end guards to access the adjustment screws.

Figure 5-9: Removing End Guards

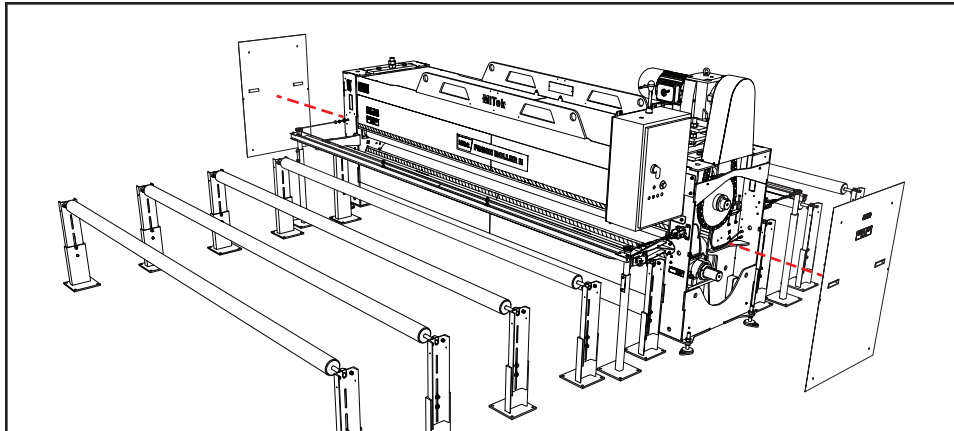

Two 16' 2x4 boards

Level

Standard hex key set

Standard wrench set

Rubber mallet



See page 79 for more on manual controls.



4. Loosen the jam nuts on the adjustment screws at both ends of the guide roller. See Figure 5-10.

Figure 5-10: Guide Roller Adjustment Bracket Jam Nut Locations

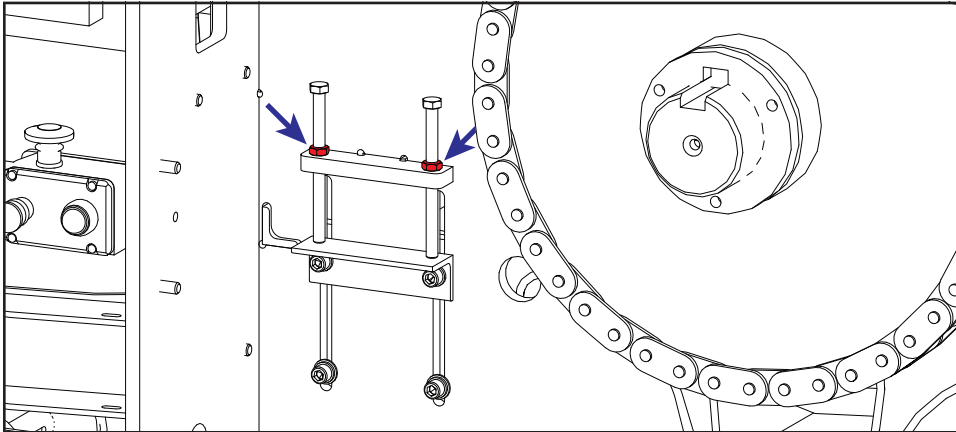

5. At both ends of the guide roller, loosen the screws that hold the guide roller mount to the frame a quarter turn. See Figure 5-11.

Figure 5-11: Guide Roller Mount Screw Locations

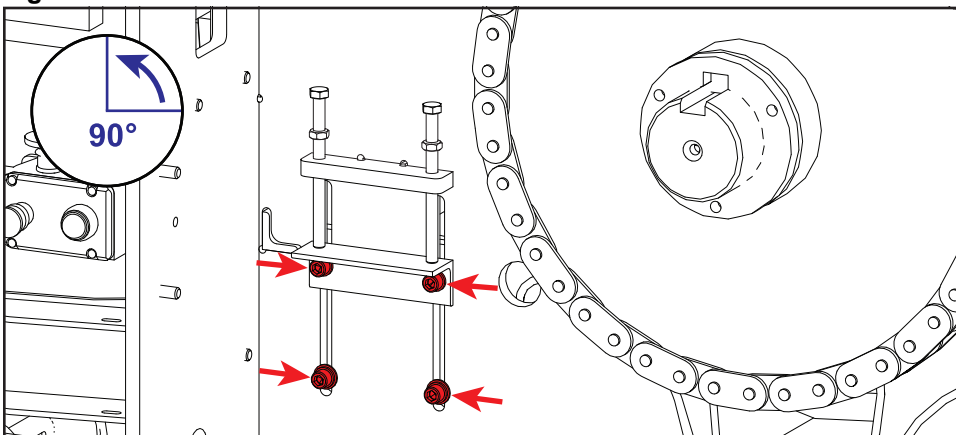

6. Use the adjustment screws to lower the adjustment bracket. Follow the guidelines below.
 - Adjust each adjustment screw equally to keep the bearing level.
 - Adjust each side of the press only 1/4" at a time before switching sides. Adjusting more than 1/4" on one side at a time may cause the bearings to bind.
 - Adjust the guide roller until it just barely touches the 2x4s.

Figure 5-12: Guide Roller Adjustment

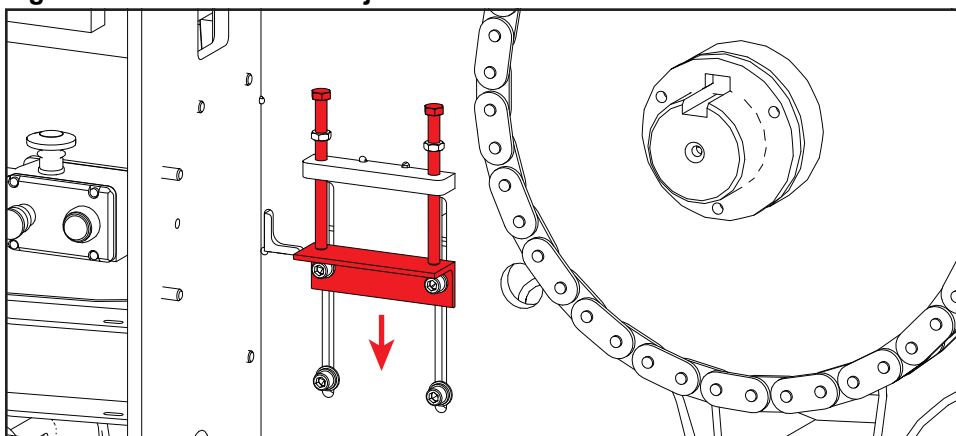

7. Check the guide roller to make sure it is level.
8. Tighten the jam nuts at both ends of the press.
9. Once the guide roller is adjusted properly, replace the end guards.
10. Remove the lock and tag. Use the manual controls to remove the 2x4s from the press.
11. Resume operation.

Adjusting Press Rollers

The top press roller is a powered roller that adjusts vertically. The press rollers are adjusted at the factory and should not require adjustment under normal operation. If you need to adjust the press rollers, use the following steps:

1. Lockout/tagout on the electrical enclosure.
2. Remove the end guards and drive chain guard.

Figure 5-13: Removing Guards

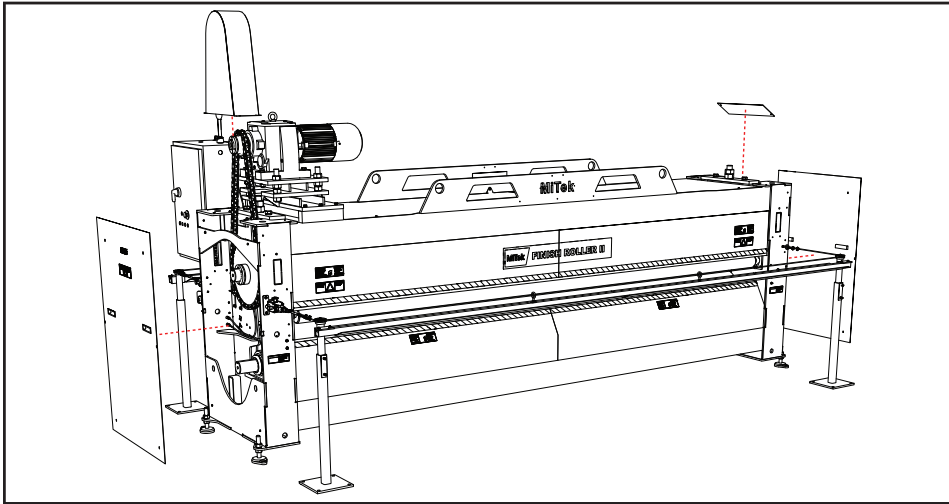

3. Remove the chains as necessary. If necessary, see page 93 for more detail about removing chains.
 - If you are lowering the press roller, remove the drive chain.
 - If you are raising the press roller, remove the idler chain.

Figure 5-14: Chain Locations

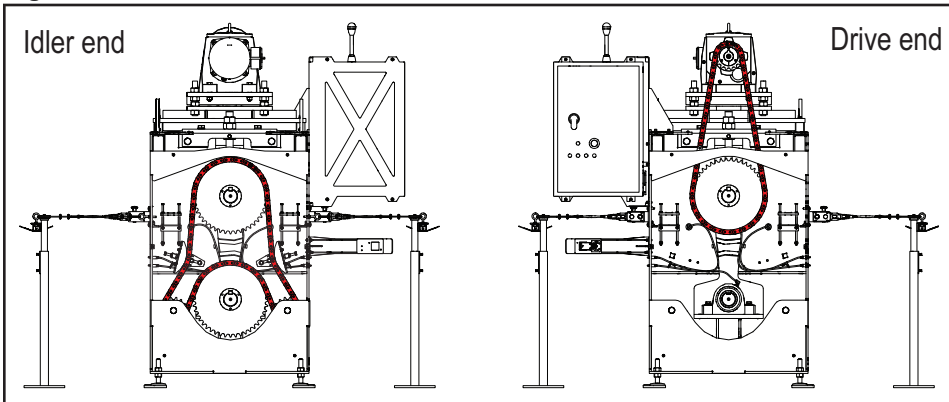

Standard hex key set

Standard socket wrench set

Standard combination wrench set

Pliers

Level

4. Loosen the screws that lock the bearing nuts in place on both ends of the frame. The screw at the idler end is shown in Figure 5-15.

Figure 5-15: Set Screw Location

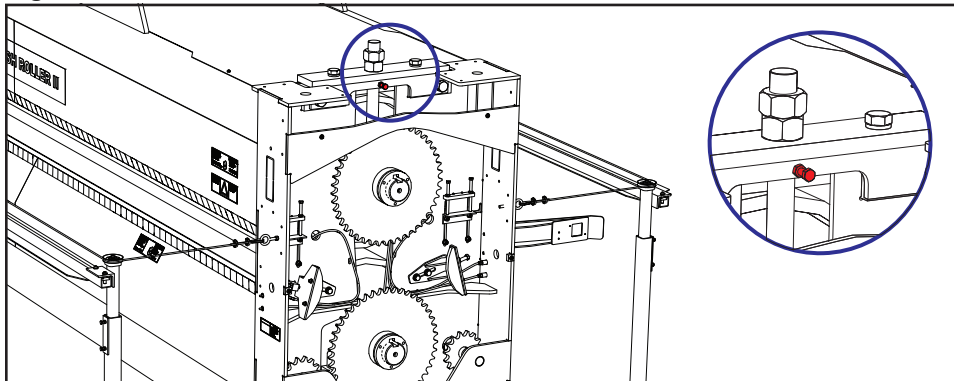

5. Adjust the take-up bearings holding the top press roller by using the following steps:
 - a) Loosen nuts A and C on the shaft that holds the take-up bearing, shown in Figure 5-16.

Figure 5-16: Adjusting the Roller Height

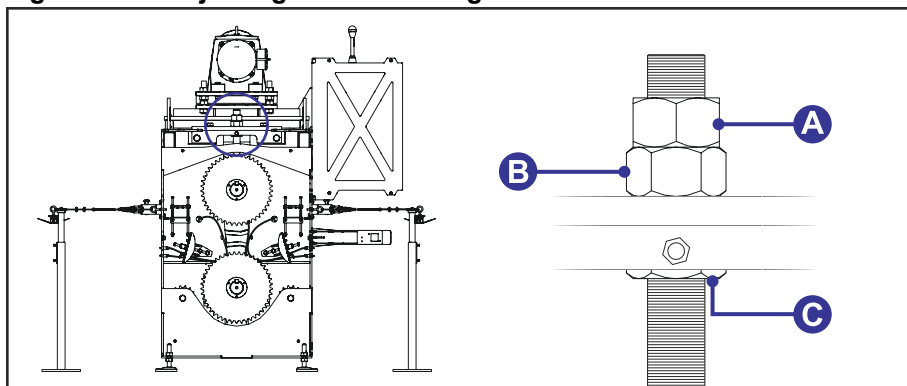

- b) Use nut B to adjust the top press roller height. Switch to the other take-up bearing on the opposite side of the press after moving nut B no more than 1/2" up or down.
 - Turn nut B clockwise to raise the top press roller.
 - Turn nut B counterclockwise to lower the top press roller.
 - c) Once both take-up bearings are adjusted equally, verify that the top press roller is parallel to the bottom press roller.
 - d) Tighten nut A and nut C on both threaded rods.
6. Tighten the screw on nut C at both ends of the press.
7. Replace the chains. Refer to page 93 if necessary. Re-tension each chain according to the instructions on page 94.
8. Replace the guards.
9. Remove the lock and tag. Resume operation.

Electrical System

Electrical Enclosure

NOTICE	
	<p>Never use compressed air inside of electrical enclosures. It may force contaminants into electrical connections.</p> <p>Use a vacuum to remove dust from electrical enclosures. Canned air is acceptable after vacuuming.</p>

Vacuum the electrical enclosure every week.

Photoelectric Sensor

The photoelectric sensor mounts to the outside of the lumber guide. The photoelectric sensor senses a truss, sounds the horn, and signals the VFD to start the motor.

Photoelectric Sensor

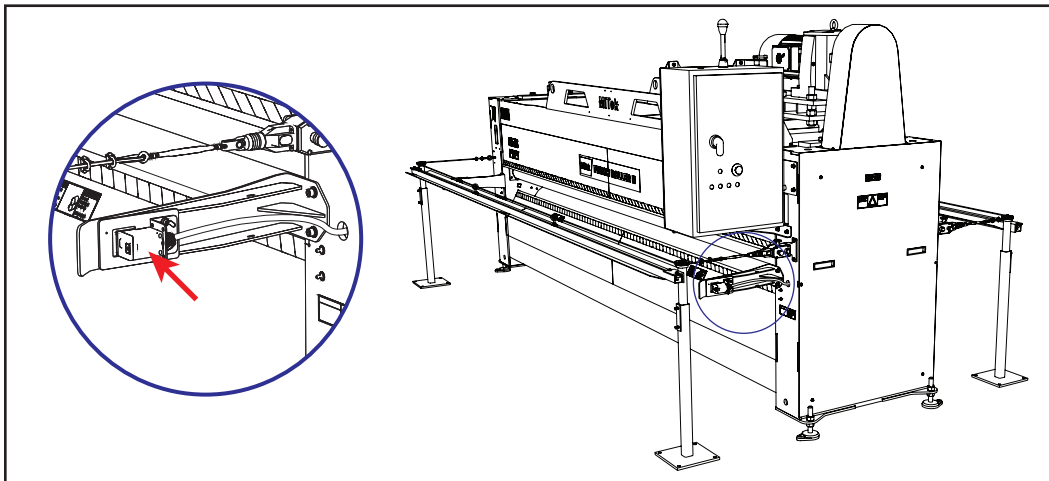

Aligning the Photoelectric Sensor

The red LED on the top of the photoelectric sensor blinks rapidly when properly aligned. After making sure that the lumber guides are adjusted to the same height, you may adjust the sensor in one of two ways.

- Loosen the nut on the rear of the sensor to tilt the sensor up or down. Re-tighten the nut after the sensor is properly aligned.
- Loosen the screw on the sensor bracket to rotate the sensor clockwise or counterclockwise. Re-tighten the screw after the sensor is properly aligned.

After initial alignment, the photoelectric sensor does not need realignment under normal operation.



Figure 5-17: Photoelectric Sensor

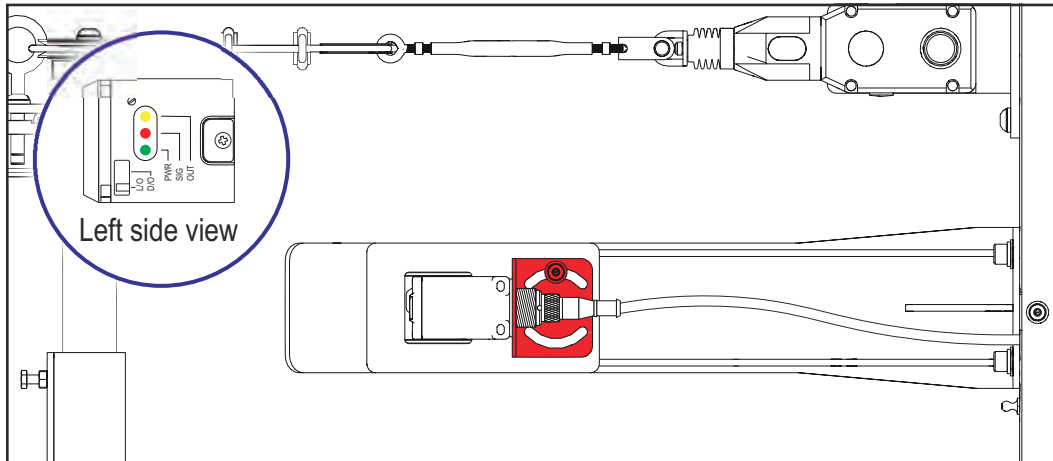

Standard hex key set
Adjustable wrench

Table 5-4: Photoelectric Sensor Indicator Lights

LED Color	State	Meaning When Illuminated
Green	Solid	Sensor has power
Red	Rapid blinking	Sensor is aligned correctly
Yellow	Solid	Sensor is detecting an object (e.g. a truss)

Pull-Cord

The pull-cord is part of the safety circuit. The pull-cord is anchored to the frame or an exterior wall with a switch on one side and an eye bolt on the other with two stands in between. See Figure .

When the cable is pushed or pulled 4" inches from its resting position, the cable triggers an E-stop.

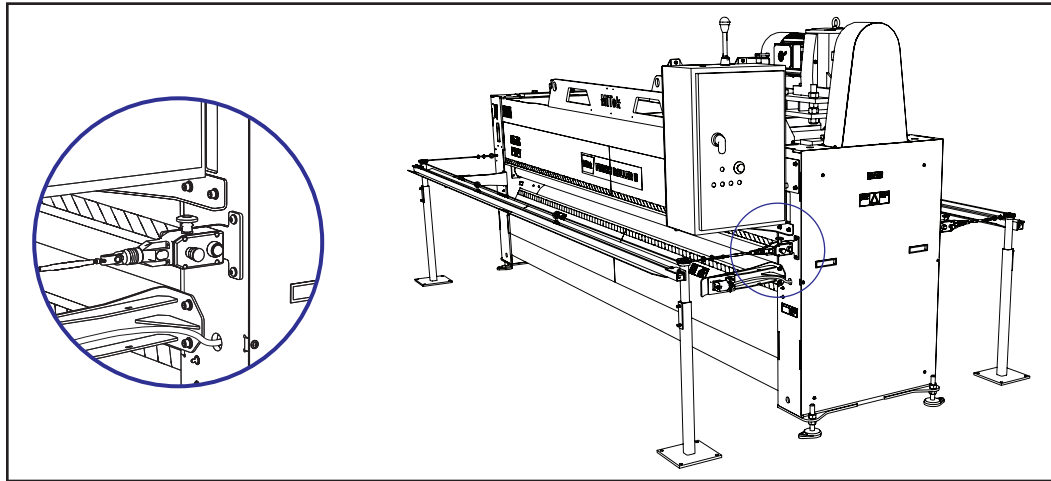

Pull-Cord Switch Attached to Press



See page 73 for more information about E-stops.

Checking the Tension of the Pull-Cord

If the pull-cord isn't adjusted properly, the press may not stop properly or may experience a fault. Even after proper tensioning, the pull-cord may become more taut or more slack over time due to changes in temperature. Check the tension of the pull-cord before the start of each shift and after performing any maintenance to the press.

 WARNING	
	<p>Make sure the pull-cord is tensioned properly before starting each shift and after performing maintenance. Adjust the tension of the pull-cord if necessary.</p>
	<p>A pull-cord that is tensioned incorrectly may fail to stop the press in an emergency, resulting in serious physical injury or death.</p>

To check tension, locate the clear plastic window on the pull-cord switch, shown in Figure 5-18. The green triangles should be in the center of the window.

Figure 5-18: Pull-Cord Switch Window

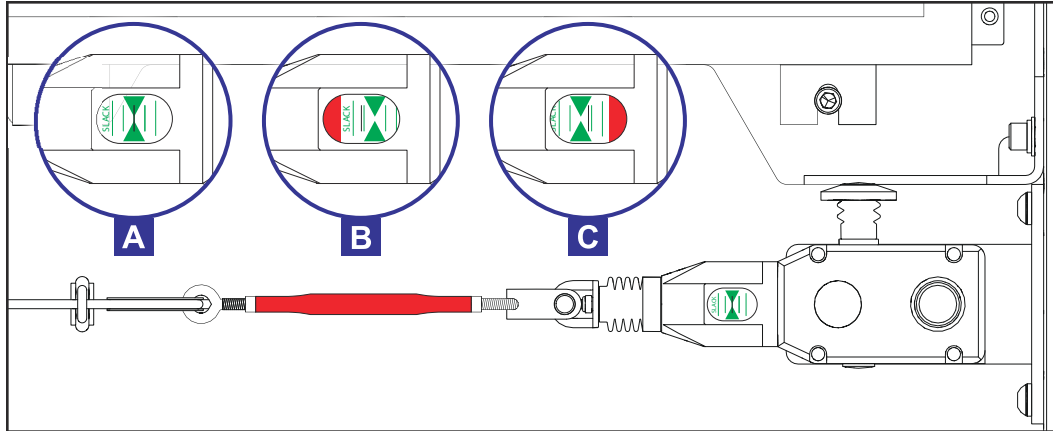

Table 5-5: Pull-Cord Tension

Position	Tensioning
A	Pull-cord is tensioned correctly
B	Pull-cord has too much slack
C	Pull-cord is too tight

Tensioning the Pull-Cord

If the green triangles are not centered, adjust pull-cord tension by using the following steps:

1. Loosen the jam nuts at each end of the turnbuckle. The turnbuckle is shown in red in Figure 5-18.
2. Twist the turnbuckle to tighten or loosen the pull-cord.
3. Tighten the jam nuts once the cable is tensioned properly.



Standard combination wrench set

Adjustable wrench

Light Curtain

Light curtains are included with presses that are used with end-eject systems. The light curtain consists of a transmitter and a receiver. In Figure 5-19, the transmitter is labeled A, and the receiver is labeled B.

If a person passes through the light curtain, the light curtain triggers an E-stop. The light curtain is not affected by a gantry head passing through it.

Figure 5-19: Light Curtain Transmitter (A) and Receiver (B)

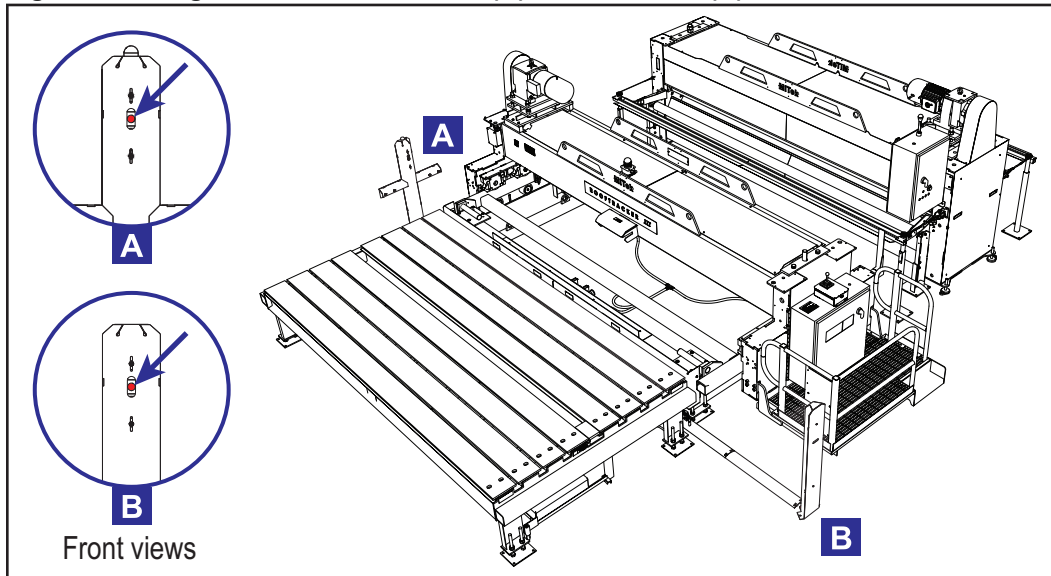

Presses configured for end-eject systems are equipped with a light curtain to prevent people from entering the restricted zone. There are sensors to mute the light curtain to allow the gantry head to pass through onto the lifter.

Cleaning the Light Curtain

Lockout/tagout before cleaning the light curtain. Clean the light curtain transmitter and receiver with a common glass cleaner and a clean, soft, lint-free cloth. Clean the transmitter and receiver every day.

When the light curtain receiver and transmitter become dirty, the dirt may prevent the press from operating properly.



Common glass cleaner

Soft, lint-free cloth

Aligning the Light Curtain

The light curtain transmitter and receiver are set 12" above the tabletop so that trusses have enough room to pass under the light curtain. The light curtain transmitter and receiver are aligned during installation. They do not need re-alignment under normal operating conditions. If necessary, align the light curtain using the following steps:

1. Lockout/tagout.
2. Remove the rear cover of the transmitter stand, labeled A in Figure 5-19.
3. Make sure that nothing is blocking the light beam between the transmitter and receiver.
4. Adjust the transmitter until the yellow LED light on the front of the receiver illuminates.

The transmitter adjusts both horizontally and vertically.

Figure 5-20: Light Curtain Adjustment Slots

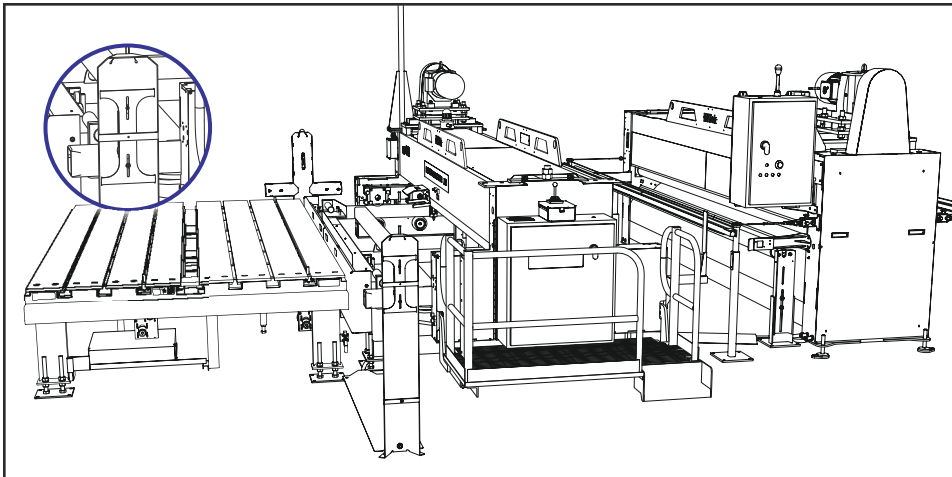

5. Tighten the screws on the transmitter bracket. Replace the cover.
6. Remove the lockout/tagout device from the E-stop. Pull the E-stop pushbutton. Press **Reset** on the main electrical enclosure and hold it for one second.
7. Resume operation.



Lockout/tagout device

Standard hex key set

Adjusting the Muting Sensors

The muting sensors are adjusted during installation. They do not need readjustment under normal operating conditions. If necessary, adjust the muting sensors using the following steps:

1. Move the gantry head so that the head is directly in front of the transmitter stand. See Figure 5-21. Actuate the E-stop pushbutton on the gantry head.

Figure 5-21: Moving the Gantry Head into Position

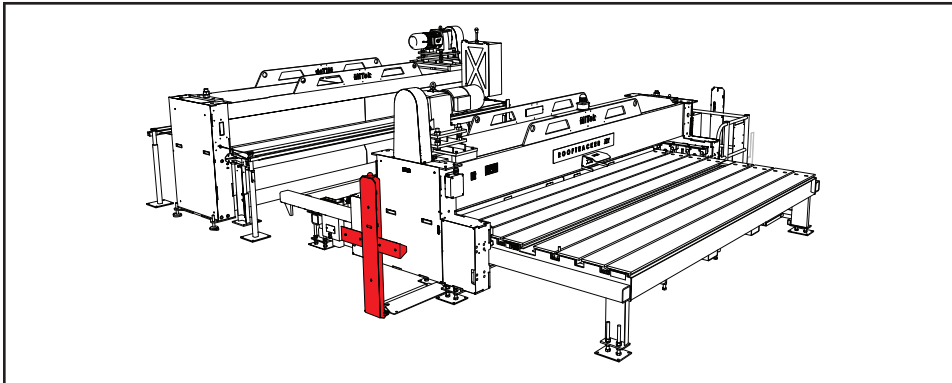

Standard hex key set
Slotted screwdriver

2. Remove the covers from back of the transmitter stand arms to locate the muting sensors. See Figure 5-22.

Figure 5-22: Transmitter Stand Covers

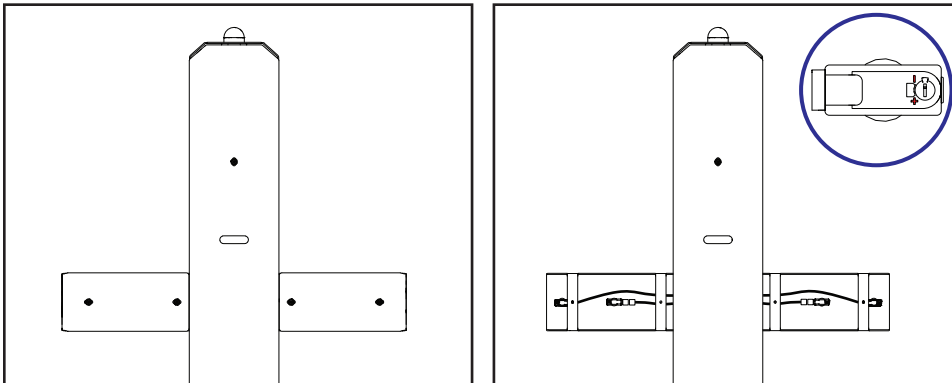

3. Verify that the first muting sensor on the right has its green LED illuminated. The green LED illuminates when the muting sensor has power.
4. Turn the muting sensor's sensitivity adjustment toward the minus (-) sign as far as possible. See the left side of Figure 5-23. The muting sensor now detects only very close objects.

Figure 5-23: Muting Sensor Adjustment

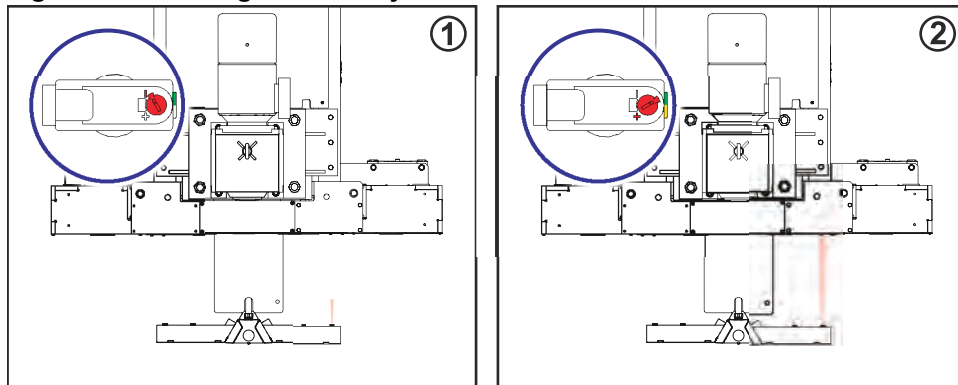
*Top views of transmitter stand and gantry head*

5. Turn the sensitivity adjustment toward the plus (+) sign until the yellow LED starts blinking. Continue turning slowly until the yellow LED turns solid. See the right side of Figure 5-23. The muting sensor is now detecting the gantry head.
6. Repeat steps 3 through 5 with the other muting sensors.
7. Make sure that the muting sensors are not detecting the tables by using the following steps:
 - a) Pull the E-stop pushbutton on the gantry head.
 - b) Move the gantry head onto the tables at least 5' from the muting sensors.
 - c) Make sure that the yellow LED is off.
If the yellow LED is still illuminated, the sensors are too sensitive and must be readjusted with the gantry head parked in front of them.
8. Replace the covers on the transmitter stand.
9. Verify that the muting sensors are functioning by using the following steps:
 - a) Go to the main electrical enclosure on the press. Press and hold **Reset** to reset the safety circuit.
 - b) Go to the gantry head. Move the gantry head onto the lifter. Verify that the light on the top of the transmitter stand
 - flashes as the gantry head passes through and
 - turns green when the gantry head is parked on the lifter.
10. Once you have verified that the muting sensors are functioning properly, perform the safety tests starting on page 10.
11. Resume operation.

VFD (Variable Frequency Drive)

The VFD is located inside the main electrical enclosure. A VFD is an important part of several electrical circuits in the Finish Roller II.

If the VFD experiences a fault, the press stops operating.

Verifying the voltage in and out of the VFD is always a good first step in the electrical troubleshooting process.

For help troubleshooting VFD faults, call MiTek Machinery Division Customer Service.

Figure 5-24: VFD

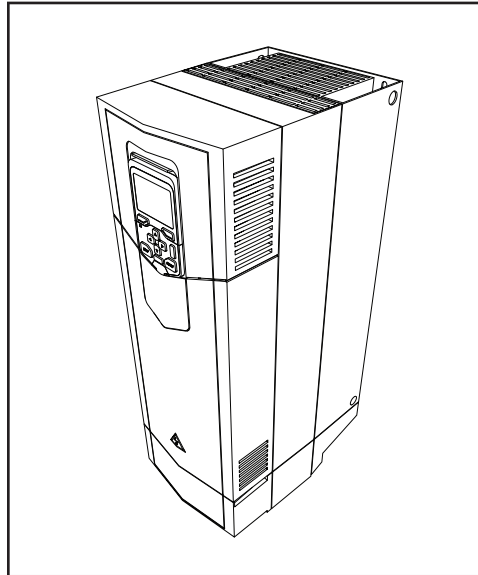

Safety Controller

The safety controller is located inside of the main electrical enclosure. It monitors the safety circuit and responds when an E-stop is triggered.

See Table A-1 on page 122 for its operating states.

The safety controller makes sure that the safety features on the press are working properly. If the press does not operate, the safety controller provides a good place to start troubleshooting the electrical system.

The safety controller has a operating temperature range shown on page 53. In extremely cold weather, it may be necessary to leave 3-phase power on overnight to keep the heater running in the main electrical enclosure.

Figure 5-25: Safety Controller

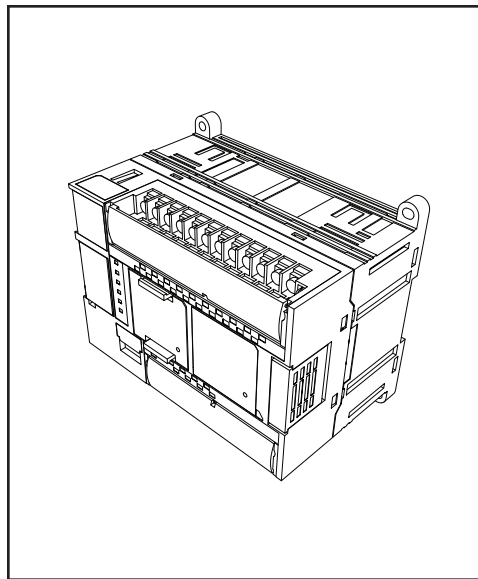

Troubleshooting

**Purpose
of Appendix**



This appendix describes possible problems and solutions that you may encounter while operating the Finish Roller II.

Using the Troubleshooting Appendix

If you have reviewed the information in the *Maintenance* chapter and this chapter but have not solved your problem, please call MiTek Machinery Division Customer Service for assistance.

Safety Notes for Troubleshooting

General Troubleshooting Safety Tips

	 WARNING
	<p>ELECTROCUTION AND CRUSH HAZARDS.</p> <p>Read all notes in this section AND the safety section in the preliminary pages before operating or maintaining this equipment.</p> <p>Most solutions are described in more detail in the <i>Maintenance</i> chapter, where there may be additional safety notes.</p>

- Read all warnings located in the safety section in the preliminary pages and adhere to them at all times.
- When the blue lock shown in the margin appears, lockout/tagout at the disconnect switch located on the equipment using approved methods described in OSHA 29 CFR 1910.147 before continuing with the procedure or troubleshooting.
- If the lockout/tagout graphic does not appear, it is recommended that you still de-energize the machine unless energy is required for the troubleshooting process. If it is absolutely necessary to troubleshoot an energized machine, follow NFPA 70E for proper procedures and personal protective equipment.
- All electrical work must be performed by a licensed electrician.
- Read this manual for information and procedures related to the specific maintenance or troubleshooting issue before attempting any maintenance.
- Safety goggles and a dust mask must be worn for all cleaning steps outlined in this manual. When using cleaning and lubrication solutions, a respirator rated for use with those solutions must be worn, as well as gloves resistant to the solution.



Electrical Troubleshooting Safety Tips

- Make sure that you have the proper tools for the job. See page 117.
- Make sure that the person performing the troubleshooting is qualified from an electrical knowledge standpoint. If you feel uncertain about troubleshooting electrical power, remember that the cost of an injury far outweighs the cost of hiring an electrician.
- Remove rings or watches. They are extremely conductive material and may catch on small components.
- Get a helper. You are most likely going to need an extra hand at some point, and you shouldn't perform electrical work without someone close by to help if you get injured.
- Be patient. Take your time and stay alert. Never take shortcuts or become too confident in what you are doing.
- Take notes recording what you have checked and what the readings were. This is a good way to check your work when you are finished. Sometimes, the machine won't work because a wire was removed for testing and overlooked when cleaning up. Having notes makes the process go much more smoothly.
- ALWAYS turn the power off if you are checking for ohms or swapping PLC cards.
- ALWAYS push an E-stop button before approaching a machine for any reason. If you are working on encoders, pushing an E-stop is especially important. An interruption to a powered encoder may cause components to move without warning.
- Wear appropriate PPE (personal protective equipment) for working with live power.

Getting Started with Troubleshooting

Tools Required

When the toolbox shown in the margin appears, you should gather the tools listed below it before beginning the procedure next to which it appears.

Before beginning the troubleshooting process or calling MiTek Machinery Division Customer Service, gather the following tools:

- Insulated slotted screwdriver
- Insulated Phillips screwdriver
- Equipment manual and drawings, including any electrical schematics
- Pen and notepad
- Multimeter

A multimeter is an electronic measuring instrument. The analog versions were referred to as a volt-ohm-meter (VOM). Digital models are referred to as digital multimeters (DMM). Your multimeter should have the following features:

- Voltage (volts) measurement
- Resistance (ohms) measurement
- Current (amps) measurement
- Ability to measure both AC and DC power
- Autoranging feature
- PPE as required by NFPA 70e



First Steps

Mechanical Troubleshooting

Always clean and lubricate the equipment as a first step in most troubleshooting processes. Most mechanical malfunctions are caused by inadequate preventative maintenance.



Electrical Troubleshooting

1. Lockout/tagout at the disconnect switch located on the equipment.

	NOTICE
	<p>Never use compressed air inside an electrical enclosure. It may force contaminants into electrical connections.</p> <p>Use a vacuum to remove dust from electrical enclosures. Canned air is acceptable after vacuuming.</p>



2. Vacuum and dust the electrical enclosure.
3. Remove the lockout/tagout equipment and attempt to run the Finish Roller II again. If that did not solve the problem, proceed with the next step.
4. Adhere to all regulations and guidelines given in NFPA 70e and in your company's energy control program. Some important safety tips are addressed on pages 115 and 116.

	 WARNING
	<p>ELECTRICUTION HAZARD.</p> <p>All electrical work must be performed by a licensed electrician.</p> <p>If it is absolutely necessary to troubleshoot an energized machine, follow appropriate guidelines.</p>

5. Determine where the electrical problem begins. To do this, you need a multimeter.
 - Determine if you are working with AC (alternating current) or DC (direct current) before checking voltage.
 - Measure incoming and outgoing voltage to and from components. Proceed in a logical order determined by your machine's specific problem, and write down the order that you check each component and the amount of voltage that the multimeter registers.



Should you lockout/tagout to perform this action safely?

Identifying Problems and Solutions

Problem	Possible cause	Possible solution	Page
Press does not operate.	No power.	Check disconnect switch and fuses.	
	No control power.	Check 24VDC power supply and fuses.	
	E-stop activated.	Reset all E-stop pushbuttons and pull-cord switches. Then reset the press.	73 74
	Pull-cord damaged or cut.	Inspect pull-cord and sheaves and replace if necessary.	
	Pull-cord not tensioned properly.	Tension pull-cord. Reset pull-cord switch. Reset the press.	109
	Light curtain (if equipped) tripped.	Check for obstructions between receiver and transmitter. Clean the receiver and transmitter. Check receiver for fault code.	110 123
	VFD experiencing a fault.	Press Reset button on main electrical enclosure.	78
	Safety controller experiencing a fault.	Cycle power to the press. If the press still does not operate, check safety controller status for fault.	122
Press operates continuously in automatic mode without a truss present	Interlocked machine (if equipped) experiencing a fault or E-stop.	Inspect interlocked machine.	
	Photoelectric sensor misaligned.	Check photoelectric sensor to see if yellow LED is continuously on. If yellow LED is continuously on, align the photoelectric sensor properly.	106



Should you lockout/tagout to perform this action safely?

Problem	Possible cause	Possible solution	Page
Press does not operate properly in automatic mode.	Interlocked stacking equipment (if equipped) is operating.	Wait until interlocked stacking equipment finishes operating.	
	Misalignment or failure of photoelectric sensor.	Check alignment of photoelectric sensor. Check voltage at photoelectric sensor. If sensor is aligned and voltage is present, may need to replace photoelectric sensor.	106
Both rollers are not turning.	Obstruction in rollers.	Inspect rollers and remove obstruction if present.	
	Failure of small drive sprocket, bushing, or key.	Check for damage. Check bushing to make sure it is tightened on shaft. May need to replace small drive sprocket, bushing, or key.	
	Failure of large drive sprocket, bushing, or key.	Check for damage. Check bushing to make sure it is tightened on shaft. May need to replace large drive sprocket, bushing, or key.	96
	Failure of motor, brake, or gearbox.	Check voltage at motor. Check voltage to make sure brake is releasing. If three-phase voltage is present and brake is releasing, inspect gearmotor and brake.	
Bottom roller is not turning.	Broken idler chain or sprocket.	Inspect idler chain and sprocket and replace if necessary.	
Horn not functioning.	Failure of horn.	Check voltage at horn.	
	Misaligned photoelectric sensor.	Align photoelectric sensor.	106
	Bad photoelectric sensor.	May need to replace photoelectric sensor.	



Should you lockout/tagout to perform this action safely?

Problem	Possible cause	Possible solution	Page
Connector plates not embedding properly.	Board not correct thickness for roller height.	Measure board and verify that it is normal thickness. If board is thicker, may need to adjust press roller.	104
	Plate not correct thickness for roller height.	Verify that plate is the normal thickness. If plate is thicker or larger, may need to adjust press roller.	104
	Press rollers are not adjusted properly.	Adjust press rollers.	104
	Take-up bearing nuts loose.	Inspect take-up bearing nuts and tighten if necessary.	
	Failure of take-up bearing.	Inspect take-up bearing and replace if necessary.	
Grinding, squealing, or other unusual sound.	Chain not properly tensioned.	Check chain tension. May need to adjust chain tension.	94
	Bearings not properly lubricated.	Lubricate bearings. If noise persists, may need to replace bearing.	100
Trusses bowing as they are pressed.	Guide rollers not adjusted far enough down.	Adjust guide rollers.	101



Should you lockout/tagout to perform this action safely?

Diagnostics

Safety Controller Diagnostics

Table A-1 provides information about the operating state of the safety controller. The MS indicator light and the MC indicator light are located on the front of the safety controller.

Table A-1: Safety Controller Operating States

MS Light	MC Light	Operating Mode	Description
Lit green	Off	Run mode	All functions are supported, including the program.
Lit green	Off	Idle mode	Initialization has been completed. The safety controller is waiting to move to Run Mode.
Flashing green/red	Off	Configuring mode	Safety controller is waiting for the configuration to be downloaded.
Flashing red	Off	Abort mode	Minor error occurred: <ul style="list-style-type: none"> • An unsupported expansion I/O unit is connected. • More than two expansion I/O units are connected. • An unsupported option board is connected. Cycle the power supply, or reset from the safety controller configurator to return to Run Mode.
Off	Flashing or lit yellow	Memory cassette mode	Data is being backed up or restored to/from a memory cassette.
Lit red	Off	Critical error (system fail)	A critical error has occurred. All operation stops, and safety controller enters the safe state.
Flashing green/red	Off	Initialization	Self-diagnosis is being performed.

More detailed troubleshooting information for the G9SP safety controller is available on the Omron website.



Should you lockout/tagout to perform this action safely?

Light Curtain Diagnostics

Table A-2 provides information about the operating state of the light curtain. The diagnostic display is located on the light curtain receiver.

Table A-2: Light Curtain Diagnostic Codes

Diagnostic Code Type	Code	Meaning of Diagnostic Code
Normal operation	88/V#	Startup / version number
Normal operation	--	Run state
Normal operation	-0	Stop state
Configuration switch fault	-1	Interlock state, waiting for start input
Configuration switch fault	21	Invalid mode selection setting
Configuration switch fault	22	Switch settings changed during operation
Safety output (OSSD) fault	26	Invalid code setting
Safety output (OSSD) fault	31	Safety output A and B are shorted together
Safety output (OSSD) fault	32	Safety output A shorted to power
Safety output (OSSD) fault	33	Safety output B shorted to power
Safety output (OSSD) fault	34	Safety output A shorted to ground
Safety output (OSSD) fault	35	Safety output B shorted to ground
Receiver fault	50	Internal fault
Setup error	60	Receiver in view of multiple transmitters sent to same scan code

More detailed troubleshooting information for the PA4600 perimeter access guarding device is available on the Omron website.

Parts List

**Purpose
of Appendix**

This appendix lists MiTek replacement part numbers for your Finish Roller II.

Using the Parts List Appendix



The parts list provided here shows spare parts that you may need to repair or maintain your Finish Roller II. Use one of the methods below to order them.



Table B-1: Ordering Parts with a Part Number

By E-Mail	By Phone
Send an e-mail to mitekparts@mii.com with all relevant information, including the part number.	Call 1-800-523-3380. Select “parts orders.”

Safety Notes for Replacement Parts

NOTICE	
	<p>Use only parts purchased from MiTek to replace parts on your Finish Roller II.</p> <p>Parts from other sources may damage your Finish Roller II.</p>

 WARNING	
	<p>ELECTRICAL HAZARD.</p> <p>All electrical work must be performed by a licensed electrician.</p> <p>Follow approved lockout/tagout procedures (OSHA 29 CFR 1910.147).</p>

 WARNING	
	<p>ELECTROCUTION AND HIGH PRESSURE HAZARDS.</p> <p>Always turn the power off by activating an E-stop when the machine is not operating.</p> <p>Always verify that all power to the machine is off and followed approved lockout/tagout procedures (OSHA 29 CFR 1910.147) before performing any maintenance.</p>

Part Numbers

Table B-2: Mechanical Parts

MiTek Part Number	Description	Drawing Number	Keep in Stock
480401	Gearmotor	68500-501	
535095	Small drive sprocket	68500-501	
547096	Small drive sprocket bushing	68500-501	
554009-106.25	Drive chain	68500-501	
544009-138.75	Idler chain	68500-501	
554386	Master link for drive or idler chain	68500-501	
554171	Offset link for drive or idler chain	68500-501	2
552052	Large sprocket	68500-501	
547097	Large sprocket bushing	68500-501	
558145	Small idler sprocket	68500-501	
541282	Split collar for small idler sprocket	68500-501	
68567	Chain tension guide	68535-501	
68450-501	Press roller assembly (3' 5")	68630-501	
71500-501	Press roller assembly (7')	68631-501	
68365-501	Press roller assembly (7' 6")	68632-501	
68366-501	Press roller assembly (8')	68633-501	
68367-501	Press roller assembly (12' 6")	68634-501	
68120-501	Press roller assembly (14')	68500-501	
68401-501	Press roller assembly (16')	68635-501	
68573-501-3	Guide roller assembly (3')	68630-501	
68573-501-7	Guide roller assembly (7')	68631-501	
68573-501-7.5	Guide roller assembly (7' 6")	68632-501	
68573-501-8	Guide roller assembly (8')	68633-501	
68573-501-12.5	Guide roller assembly (12' 6")	68634-501	
68573-501-14	Guide roller assembly (14')	68500-501	
68573-501-16	Guide roller assembly (16')	68635-501	
532011	Take-up bearing for upper press rollers	68507-501	
419612	Pillow-block bearing for lower press rollers	68500-501	
419134	Flange bearing for guide rollers	68500-501	
63062-501	Pull-cord stand (lower)	63060-XXX	
63064-501	Pull-cord stand (upper)	63060-XXX	
410010	Sheave for pull-cord stand	63060-XXX	
270016-456.00	Pull-cord	63060-XXX	
271002	Pull-cord clip	63060-XXX	
271026	Pull-cord thimble	63060-XXX	
271055	Pull-cord turnbuckle	63060-XXX	

MiTek Part Number	Description	Drawing Number	Keep in Stock
358019	Pull-cord eye bolt	63060-XXX	

Table B-3: Electrical Parts

MiTek Part Number	Description	Drawing Number	Keep in Stock
92286-503	VFD (programmed)	90646-502	
509296	VFD I/O module	90646-502	
509266	24VDC power supply	90646-502	
477090	Fuse (5A)	90646-502	1
516382	Fuse (1A)	90646-502	1
516383	Fuse (2A)	90646-502	1
516495	Fuse (45A)	90646-502	3
509429	Disconnect switch	90646-502	
509437	Disconnect switch shaft	90646-502	
509438	Disconnect switch pistol handle	90646-502	
92289-507	Safety controller (programmed with memory cassette)	90646-502	
509339	Contactora (24VDC)	90646-502	1
514239	Contactora (24VDC)	90646-502	1
514205	Relay (24VDC)	90646-502	
514127	Relay (24VDC)	90646-502	
513601	Blue pushbutton	90646-502	
513642	Red pushbutton	90646-502	
513641	Green pushbutton	90646-502	
513654	E-stop pushbutton	90646-502	
513644	Selector switch (two position)	90646-502	
513670	Selector switch (three position)	90646-502	
515000	Photoelectric sensor	90646-501	
515024	Photoelectric sensor cable	90646-501	
515753	Muting sensor	90649-501	
515764	Pull-cord switch (right hand, from enclosure end)	90646-501	
515757	Pull-cord switch (left hand, from enclosure end)	90646-501	
515766	Pull-cord switch cable	90646-501	
515835	Light curtain (end-eject systems only)	90649-501	

See Table B-2 on page 125 for the pull-cord itself.

Table B-4: Documentation Parts

Documentation	MiTek Part Number
Operations / maintenance manual	001127MANUAL-OP
Labels	See page 128

Guard Part Numbers

The guards on the Finish Roller II are shown in Figure B-1.

Figure B-1: Guards

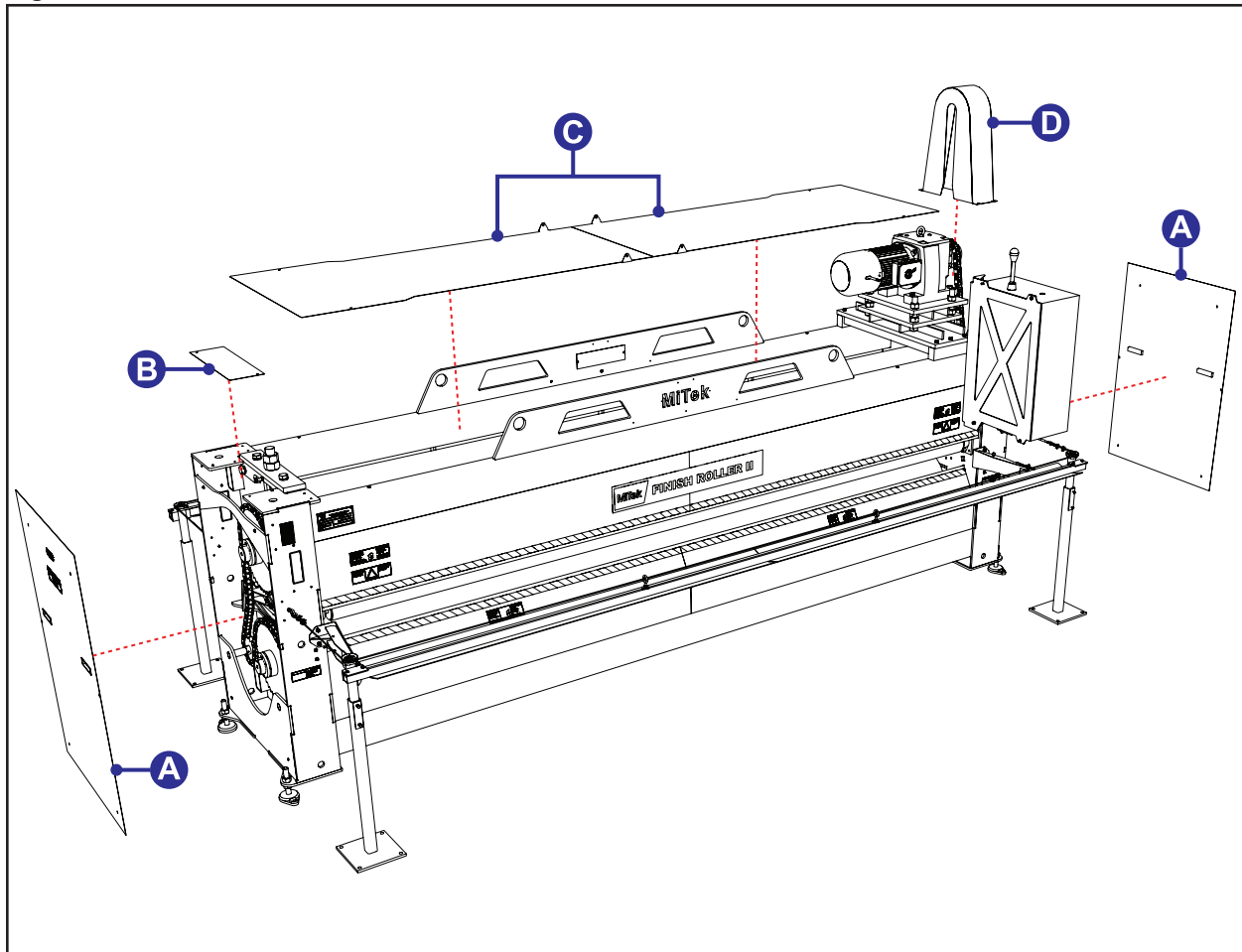

Table B-5: Guard Part Numbers





Letter	Part Number	Description
A	68519-501	End guard assembly (both ends)
B	68516	Idle side gap guard
C	See Table B-6	See Table B-6
D	68523-501	Chain guard assembly

Table B-6: Top Guard Part Numbers by Model

Letter	Part Number	Description
C	68517-101*	Top guard for 16', 14', and 12' 6" rollers
C	68517-102*	Top guard for 7', 7' 6" and 8' rollers
C	68517-103*	Top guard for 3' roller

* Must specify roller length when ordering

Label Part Numbers

Part Number	Label
691420	
691512	
691523	
691327	
691901	

Maintenance Checklist

Purpose of Appendix



This appendix consists of checklists to plan and record preventive maintenance procedures.



Using the Maintenance Checklists

Copy these checklists and place the copies with the Finish Roller II. Leave the original checklists in this manual for future use.

Checklist	Page
Daily checklist	130
Weekly checklist	131
Monthly checklist	132

Safety Notes for the Maintenance Checklists



	 WARNING
	<p>CRUSH HAZARD.</p> <p>Perform the safety tests described on page 10 before operating the machine after performing maintenance or repairs.</p>

	 WARNING
	<p>ELECTROCUTION HAZARDS.</p> <p>Always turn the power off by activating an E-stop when the machine is not operating.</p> <p>Always verify that all power to the machine is off and followed approved lockout/tagout procedures (OSHA 29 CFR 1910.147) before performing any maintenance.</p>

Daily Checklist

Month and year _____

Week of _____



	 WARNING
	<p>Lockout/tagout before performing maintenance.</p> <p>If power is required, make sure all personnel are clear of the restricted zone.</p>

Action	Shift	Page	Initials / Date					
Perform safety test	1	10						
	2							
	3							
Check pull cord tension	1	109						
	2							
	3							
Clean light curtain transmitter and receiver	1	110						
	2							
	3							

Date	Notes
_____	_____
_____	_____
_____	_____
_____	_____
_____	_____
_____	_____

Weekly Checklist

Year _____



	 WARNING
	<p>Lockout/tagout before performing maintenance.</p> <p>If power is required, make sure all personnel are clear of the restricted zone.</p>

Action	Page	Initials / Date					
Vacuum any accumulation of dust or dirt from the electrical enclosure (do NOT use compressed air)	106						
Check chain tension of drive chain and adjust if necessary	94						
Check chain tension of idler chain and adjust if necessary	94						
Check screws in terminals to make sure they are tight	-						

Date	Notes
_____	_____
_____	_____
_____	_____
_____	_____
_____	_____
_____	_____

Monthly Checklist

Year _____

	 WARNING
	<p>Lockout/tagout before performing maintenance.</p> <p>If power is required, make sure all personnel are clear of the restricted zone.</p>

Action	Months (one shift)	Months (two shifts)	Page	Initials / Date			
Lubricate drive chain	1	0.5	93				
Lubricate idler chain	1	0.5	93				
Verify tightness of motor mount nuts	1	0.5	88				
Check gearbox oil level	1	0.5	89				
Verify tightness of screws on idler shaft	2	1	95				
Lubricate take-up bearings on the press rollers	12	6	100				
Lubricate flange bearings on the guide rollers	12	6	100				
Drain and refill gearbox oil	24	12	89				

Date	Notes
_____	_____
_____	_____
_____	_____
_____	_____
_____	_____
_____	_____

Drawing Set

**Purpose
of Appendix**

This appendix consists of a list of schematics and other drawings to help you understand and troubleshoot your machine.

Drawings are inserted in the back of the manual or included in a separate binder, depending on the machine.

Description	Drawing Number
Mechanical	
3' press assembly with pull-cords	68630-501
7' press assembly with pull-cords	68631-501
7' 6" press assembly with pull-cords	68632-501
8' press assembly with pull-cords	68633-501
12' 6" press assembly with pull-cords	68634-501
14' press assembly with pull-cords	68500-501
16' press assembly with pull-cords	68635-501
End guard assembly	68519-501
Pull-cord assembly (right-hand) (12' 6" and over)	63060-501
Pull-cord assembly (right-hand) (8' and under)	63060-601
Pull-cord assembly (left-hand) (12' 6" and over)	63060-502
Pull-cord assembly (left-hand) (8' and under)	63060-602
Chain tensioner assembly	68535-501
Take-up bearing assembly	68507-501
Light curtain assembly (applies to end-eject systems only)	68627-501
Electrical	
Electrical schematic	90646
Electrical assembly	90646-501
Electrical enclosure assembly	90646-502
Electrical assembly (applies to end-eject systems only)	90649-501

Document Evaluation

**Purpose
of Appendix**

This appendix provides a form so that you may evaluate this manual.

MiTek Machinery Division makes a continuous effort to provide customers with helpful, accurate documentation.

Please complete this form to provide us with comments or suggestions that improve the quality of our documentation.

Document Evaluation Form

Finish Roller II	Operation and Maintenance Manual	001127MANUAL-OP REV. A
------------------	----------------------------------	------------------------

General Evaluation

	Poor	Fair	Good	Excellent
Content				
Organization				
Accuracy				
Clarity				
Completeness				
Illustrations				
Readability				

Specific Evaluation

Identify any inaccuracies in this manual. Please include page numbers.	
What are the best features of this manual?	
What are the worst features of this manual?	
Name:	Date:
Company:	Address:
Phone:	E-mail:
Return the form by mail: MiTek Machinery Division 301 Fountain Lakes Industrial Drive Saint Charles, MO 63301 Attn: Engineering Manager	Return this form by fax: 636-328-9218 Attn: Engineering Manager
If you do not receive a reply within 45 days, please call Machinery Division Customer Service and ask for the documentation specialist or engineering manager.	

Glossary

**Purpose
of Appendix**

This appendix provides definitions of terminology that apply to your machine.

actuate	to activate, put into action
affected employee	an employee whose job requires him or her to operate or use a machine or equipment on which servicing or maintenance is being performed under lockout or tagout, or whose job requires him or her to work in an area in which such servicing or maintenance is being performed
amperage	the strength of an electric current, expressed in amperes
authorized employee	a person who locks out or tags out a machine or equipment in order to perform servicing or maintenance on that machine or equipment; an affected employee becomes an authorized employee when that employee's duties include performing servicing or maintenance covered under this section
beacon	a light that displays one of several colors to represent the state of the machine
bus bar	an electrical device that allows multiple gantry heads to be used simultaneously
chain tensioner	a crescent-shaped pad fitted to the chain tension bracket that keeps tension on the idler chain
connector plate	the nail-plate that is embedded into production material to hold it together
end-eject	a pneumatic system that raises the truss off the tables and allows the truss to be manually pushed or pulled off the end of the tables; this system requires that the gantry head rolls back over the truss or a device must be installed to raise the gantry head when it is parked
energized	connected to an energy source or containing residual or stored energy
energy isolating device	a mechanical device that physically prevents the transmission or release of energy, including but not limited to the following: manually operated electrical circuit breaker; a disconnect switch; a manually operated switch by which the conductors of a circuit can be disconnected from all ungrounded supply conductors, and in addition, no circuit can be operated independently; a line valve; a block; and any similar device used to block or isolate energy—push buttons, selector switches, and other control circuit type devices are not energy isolating devices

energy source	any source of electrical, mechanical, hydraulic, pneumatic, chemical, thermal, or other energy
gantry head	the entire traveling weldment that houses a roller to embed connector plates
guide rollers	the pair of small rollers that are used to keep trusses from bowing as they go through the press rollers
inner side	refers to the end of the gantry head housing; the side closest to the tables; both ends have an inner side—one can see the inner side of both ends when standing on or between the tables
jigging	any of several devices used to hold the truss in place on the tables
layout	a scaled diagram of the location of components and the space that they occupy
light curtain	the perimeter access guarding device that uses multiple light beams to detect when something or someone has entered the restricted area (used with end-eject systems only); see also <i>receiver bar</i> and <i>transmitter bar</i>
lockout device	a device that utilizes a positive means such as a lock, either key or combination type, to hold an energy isolating device in the safe position and prevent the energizing of a machine or equipment, including blank flanges and bolted slip blinds; should be standardized within the facility in at least one of the following criteria: color; shape; or size; and additionally, in the case of tagout devices, print and format shall be standardized
lockout/tagout	a means of isolating a piece of equipment from its energy source so maintenance can safely occur; guidelines provided in OSHA 29 CFR 1910.147
lumber guides	a pair of arms that extend from the press frame to keep the truss centered as it enters the press; one of the lumber guides has the photoelectric sensor mounted to it
master link	a specific type of link in a chain which uses removable clips or pins that allow the link to be disassembled and the chain to be removed
motor end	used to indicate which end of the gantry head is being discussed; the end of the gantry head that houses the motor
muting sensor	a photoelectric sensor used as part of a light curtain on an end-eject system to detect the presence of a gantry head; muting sensors prevent nuisance trips when a gantry head moves through a light curtain
operator control interface	the method in which the operator controls the machine; it may be a touch screen, a control panel, etc.
perimeter safety cable	see <i>pull-cord</i>

photoelectric sensor	a sensor mounted to the lumber guides on the infeed of the press that uses reflected light to detect trusses
plate	see <i>connector plate</i>
PLC	(programmable logic controller) a solid-state control device that can be programmed to control process or machine operations. It consists of five basic components: processor, memory, input/output module, the power supply, and the programming device.
port	a connection point for a peripheral device
press rollers	the large pair of rollers used to finish embedding connector plates into trusses
proximity switch	a switch that uses an electromagnetic field to detect when an object is near, there is no physical contact between the object and the switch; inductive proximity switches detect only metal objects, capacitive proximity switches can sense both metallic and non-metallic objects
pull-cord	a steel cable with a red plastic covering that triggers an emergency stop when someone pulls it
qualified person	a person or persons who, by possession of a recognized degree or certificate of professional training, or who, by extensive knowledge, training, or experience, has successfully demonstrated the ability to solve problems relating to the subject matter and work—ANSI B30.2-1983; one who has skills and knowledge related to the construction and operation of the electrical equipment and installations and has received safety training on the hazards involved—NEC2002 Handbook
receiver bar	the light bar that receives the signal from the transmitter bar; every light curtain consists of a receiver bar and a transmitter bar
side-eject	a pneumatic system that raises the truss off the tables and allows the truss to be manually pushed or pulled off the side of the table and onto the stand-alone conveyors
stand-alone conveyor	the conveyor system that carries the truss from the tables to the Finish Roller and out to the stacker
tagout device	a prominent warning device, such as a tag and a means of attachment, which can be securely fastened to an energy isolating device in accordance with an established procedure, to indicate that the energy isolating device and the equipment being controlled may not be operated until the tagout device is removed; should be standardized within the facility in at least one of the following criteria: color; shape; or size; and additionally, in the case of tagout devices, print and format shall be standardized
take-up bearing	adjusts the height of the roller

tensioner	<i>see</i> chain tensioner
torque	a turning or twisting force
transfer roller	a motorized roller sitting perpendicular to the tables on an auto-eject system; it automatically transfers the truss from the Ejectors to the stand-alone conveyors
transmitter bar	the light bar that transmits the signal to the receiver bar; every light curtain consists of a receiver bar and a transmitter bar
turnbuckle	a device with two threaded rods, such as screws, that moves the ends of the rods closer together or farther apart to tension a cable
VFD	(variable frequency drive) controls the speed of the machine
voltage	Equal to the difference of electric potential between two point on a conducting wire carrying a constant current of one ampere when the power between the points is one watt

Index

**Purpose
of Appendix**

This appendix consists of an index to assist in navigating the manual.

A

automatic mode 80
avisos de seguridad *vea los simbolos de seguridad*

B

beacon
 colors 76
 location 76
bearings
 lubrication 100

C

chains
 lubrication 93
 replacing tensioner 95
 tensioning 94
checklists
 daily checklist 130
 maintenance 129
 monthly checklist 132
 weekly checklist 131
cleaning electrical enclosure *see* electrical enclosure
compressed air 85
conformidad
 de seguridad 46
contact information 49
corrections iii
customer service 49

D

disconnect switch
 location 75
document evaluation 135
drawing set 48

E

electrical enclosure
 vacuuming 106
electrical requirements *see* installation requirements
e-mail support *see* customer service
emergency stop *see* E-stop
errors iii
E-stop 73
 checking function 10
 disconnect switch 75
 light curtain 74
 pull-cord 74

pushbuttons 76
evaluation of document 135

G

garmotor
 adjusting air gap 91
 changing direction 88
 lubrication 89
 manually releasing brake 88
 replacing brake pad 90
guards 127

H

horn 77

I

indicators on machine 76, 77
installation of pull-cord *see* pull-cord
installation requirements 54
installing photoelectric sensor *see* photoelectric sensor

L

legal iii
legal notice iii
lifting press 57
light curtain
 aligning 111
 checking function 14
 cleaning 110
 operation 74
 overview 110
lockout/tagout
 electrical procedure 6, 8
 procedure 29
 symbol 84
lubrication
 bearings 100
 chains 93
 garmotor 89

M

Machinery Division Customer Service 49
maintenance
 checklists 129
 safety 83
major components 51, 52

- manual
 - introduction 47
 - navigation 48
 - purpose 47
 - understanding 48
- manual evaluation *see* document evaluation
- manual mode 79
- marking restricted zone 71
- O**
- operating temperature *see* installation requirements
- operation
 - starting 78
 - stopping 73
- P**
- parts list 124
 - electrical 126
 - guards 127
 - labels 128
 - mechanical 125
- patents iii
- perimeter safety cable
 - adjusting 108
- perimeter safety cable *see* pull-cord
- phone support *see* customer service
- photoelectric sensor
 - aligning 106
 - installation 62
 - overview 106
- press weight *see* weight
- pull-cord
 - checking function 12
 - installation 64, 67
 - operation 74
 - overview 108
 - resetting 74
 - tensioning 108
- purpose of manual 47
- R**
- replacement parts *see* parts list
- restricted zone 15, 16, 71
- return goods iii
- reversing direction of motor 88
- rollers
 - adjusting guide rollers 101
- S**
- safety
 - during troubleshooting 115
 - general rules 2
 - indicators 1
 - lockout/tagout 5
 - marking restricted zone 16
 - restricted zone 15
 - safety test 33
 - signal words 1
 - symbols 17
 - tests 10
 - troubleshooting with energy 9
- safety controller
 - diagnostic codes 122
 - overview 114
- safety regulations 22
- safety signs *see* safety symbols
- safety conformity 22
- simbolos
 - de seguridad 41
- spare parts *see* parts list
- specifications 53
- sprocket
 - replacing 96
- stickers *see* parts list
- stop motion *see* E-stop
- support *see* customer service
- switches
 - disconnect 75
- T**
- tensioner *see* chains
- troubleshooting 119, 122, 123
- V**
- variable frequency drive *see* VFD
- VFD
 - overview 114
- W**
- weight 57
- weights 53