

ICC-ES Evaluation Report

ESR-4517

Reissued January 2024

Revised May 2024

Subject to renewal January 2025

This report also contains:

- LABC Supplement

- FBC Supplement

ICC-ES Evaluation Reports are not to be construed as representing aesthetics or any other attributes not specifically addressed, nor are they to be construed as an endorsement of the subject of the report or a recommendation for its use. There is no warranty by ICC Evaluation Service, LLC, express or implied, as to any finding or other matter in this report, or as to any product covered by the report.

Copyright © 2024 ICC Evaluation Service, LLC. All rights reserved.

<p>DIVISION: 06 00 00 — WOOD, PLASTICS AND COMPOSITES</p> <p>Section: 06 05 23 — Wood, Plastic and Composite Fastenings</p>	<p>REPORT HOLDER: MITEK® INC.</p> 	<p>EVALUATION SUBJECT: MITEK STRUCTURAL CONNECTORS FOR WOOD FRAME CONSTRUCTION</p>	
---	---	---	---

1.0 EVALUATION SCOPE

Compliance with the following codes:

- 2024, 2021, 2018, 2015 and 2012 [International Building Code® \(IBC\)](#)
- 2024, 2021, 2018, 2015 and 2012 [International Residential Code® \(IRC\)](#)

For evaluation for compliance with codes adopted by [Los Angeles Department of Building and Safety \(LADBS\)](#), see [ESR-4517 LABC and LARC Supplement](#).

Property evaluated:

Structural

2.0 USES

The MiTek structural connectors described in this report (see [Table 8](#) for complete listing) are used for connecting wood framing members in accordance with Section 2304.10.4 of the 2024 and 2021 IBC, Section 2304.10.4 of the 2024 and 2021 IBC (Section 2304.10.3 of the 2018 and 2015 IBC and 2304.9.3 of the 2012 IBC) or in structures regulated under the IRC when an engineered design is submitted to, and approved by, the code official, in accordance with Section R301.1.3 of the IRC.

3.0 DESCRIPTION

3.1 CSH-TZ Concealed Stringer Hanger:

The CSH-TZ Concealed Stringer Hanger provides concealed connection for attaching a stair stringer to a rim joist or other header. The seat of the hanger is adjustable to match the slope of the stair stringer. The reversible design allows the connector to be used on the left or right side of the stair stringer, with the tabs positioned towards the inside of the stringer. The CSH-TZ is cold-formed from No. 18 gage steel and is prepunched for installation with 10d-by-1¹/₂-inch-long nails into the header and joist, along with diamond shaped holes in each flange allowing for temporary attachment with woodscrews to aid in installation of the connector. Embossed instructions on each flange guides the installer in proper placement and fastener installation.

3.2 HDQIF Inverted Flange Face Mount Hangers:

The HDQIF Face Mount Inverted Flange Hanger is designed to support headers, joists and trusses. The HDQIF Face Mount Hanger is cold-formed from No. 14 gage steel; and is pre-punched for 1/4-inch-by-3-inch WS3 wood screws into supporting member, and either 1/4-inch-by-1¹/₂-inch WS15 wood screws or 1/4-inch-by-3-inch MiTek WS3 wood screws into the supported member. WS wood screws are proprietary screws described in [ESR-2761](#) and are shipped with the hangers.

3.3 HTC Heavy Truss Deflection Clip:

The HTC4 Heavy Truss Clip provides lateral support for non-load bearing walls while allowing floor and roof trusses to deflect. The HTC4 is cold-formed from No. 16 gage steel; and is pre-punched for 10d-by-1 $\frac{1}{2}$ -inch nails into plate and 10d-by-1 $\frac{1}{2}$ -inch nails into the truss/rafter.

3.4 JDS Purlin Hangers:

The JDS Purlin Hanger is designed for purlin applications to provide double shear nailing. The JDS Purlin Hanger is cold-formed from No. 18 gage steel; and is pre-punched for 10d-by-1 $\frac{1}{2}$ -inch nails into header and 10d common nails into the joist. It can be installed in either a single- or double-sided configuration.

3.5 JLIF-TZ Inverted Flange Face Mount Hangers:

The JLIF-TZ Inverted Flange Joist Hanger is designed as a face-mount hanger to support joists of nominal lumber dimensions. The JLIF-TZ is cold-formed from No. 18 gage steel; and is pre-punched for 10d or 16d common nails into the header and 10d-by-1 $\frac{1}{2}$ -inch nails into the joist.

3.6 MUS Slant Nail Face Mount Joist Hangers:

The MUS Slant Nail Joist Hanger is designed for face-mount applications to provide double shear nailing for joist/truss-to-beam connections. The MUS Slant Nail Joist Hanger is cold-formed from No. 18 gage steel and is pre-punched for 10d common nails into both the header and the joist.

3.7 RBC Roof Boundary Clips:

The RBC Roof Boundary Clip is designed to connect roof blocking to a wall top plate for a lumber connection having an angle ranging from 0 to 45 degrees. The RBC is shipped flat and bent to the correct angle in the field. The RBC Roof Boundary Clip is cold-formed from No. 20 gage steel and is pre-punched for 10d-by-1 $\frac{1}{2}$ -inch nails into the top plate and 10d-by-1 $\frac{1}{2}$ -inch nails into the blocking.

3.8 Materials:

3.8.1 Steel: The specific types of steel and corrosion protection for each product are described in [Table 8](#) of this report. Minimum steel base-steel thicknesses for the different gages are shown in the following table:

GAGE NO.	MINIMUM BASE-STEEL THICKNESS (inch)
20	0.033
18	0.044
16	0.055
14	0.070

For SI: 1 inch = 25.4 mm.

3.8.2 Wood: Wood members used with the connectors in this evaluation report must be either sawn lumber with a minimum specific gravity of 0.50 or approved structural engineered lumber (including structural composite lumber and prefabricated wood I-joists) with a minimum equivalent specific gravity of 0.50, unless otherwise noted in the applicable table within this report. The connectors must be used in dry, protected conditions, where the moisture content of the wood members does not exceed 19 percent for sawn lumber, 16 percent for glulam, and as required for engineered lumber. Use in other conditions must be addressed by design in accordance with Section 4.1 of this report. For use with pressure-preservative and fire-retardant treated wood, see Section 3.8.4.

3.8.3 Fasteners:

3.8.3.1 Nails: Nails used for connectors described in this report must be bright or hot-dipped galvanized carbon steel nails complying with material requirements, physical properties, tolerances, workmanship, protective coating and finishes, and packaging requirements specified in ASTM F1667; and must have lengths, diameters and bending yield strengths, F_{yb} , as shown in the table below.

FASTENER DESIGNATION	FASTENER LENGTH (inches)	BASE METAL SHANK DIAMETER (inch)	MINIMUM REQUIRED F_{yb} (psi)
10d x 1 $\frac{1}{2}$	1.5	0.148	90,000
10d common	3.0	0.148	90,000
16d common	3.5	0.162	90,000

For SI: 1 inch = 25.4 mm, 1 psi = 6.895 kPa.

¹Galvanized nails must be used with the connectors in this report with TZ designation.

3.8.3.2 Wood Screws: The wood screws required for connectors described in [Table 2](#) of this report must be MiTek WS series wood screws, as described in [ESR-2761](#).

3.8.4 Use in Treated Wood: Connectors and fasteners used in contact with preservative-treated or fire-retardant-treated wood must comply with Section 2304.10.6 of the 2024 and 2021 IBC (Section 2304.10.5 of the 2018 and 2015 IBC; Section 2304.9.5 of the 2012 IBC) or Section R304.3 of the 2024 IRC (Section R317.3 of the 2021, 2018, 2015 and 2012 IRC), as applicable. The lumber treater or the holder of this report (MiTek), or both, should be contacted for recommendations on the appropriate level of corrosion resistance to specify for the connectors, as well as the connection capacities of the fasteners used with the specific proprietary preservative-treated or fire-retardant-treated lumber. Fasteners used in contact with preservative-treated or fire-retardant-treated wood must be hot-dipped galvanized or of other materials and finishes where evaluated in an ICC-ES evaluation report for use in the applicable treated wood. The holder of this report (MiTek) should be contacted for recommendations for use of WS screws in treated wood.

4.0 DESIGN AND INSTALLATION

4.1 Design:

The allowable load capacities in [Tables 1, 2, 3, 4, 5, 6 and 7](#) are based on allowable stress design. The use of the allowable load values for the products in [Tables 1, 2, 3, 4, 5, 6 and 7](#) in this report must comply with all applicable requirements and conditions specified in this report. Tabulated allowable loads are for load duration factors, C_D , in accordance with Section 11.3.2 of the 2024, 2018 and 2015 *National Design Specification[®] for Wood Construction* (NDS) (Section 10.3.2 of the 2012 NDS for the 2012 IBC and IRC). No further increases are permitted for load durations other than those specified. Tabulated allowable loads are for connections in continuously dry conditions, typical of sawn lumber moisture content not greater than 19 percent (16 percent for glulam, or as required for engineered lumber products), and where sustained temperatures are limited to 100°F (37.8°C) or less. When connectors are installed in conditions where moisture content is expected to exceed the above value, the applicable wet service factor, C_M , must be applied. Unless otherwise noted in the tables of this report, the applicable wet service factor, C_M , is to be as specified in the NDS for dowel-type fasteners. When connectors are installed in wood that will experience sustained exposure to temperatures exceeding 100°F (37.8°C), the allowable loads in this evaluation report must be adjusted by the temperature factor for connections, C_t , specified in the NDS. Connected wood members must be checked for load-carrying capacity at the connection in accordance with Section 11.1.2 of the 2024, 2018, and 2015 NDS (Section 10.1.2 of the 2012 NDS for the 2012 IBC and IRC).

4.2 Installation:

Installation of the connectors must be in accordance with this evaluation report and the manufacturer's published installation instructions.

5.0 CONDITIONS OF USE

The MiTek structural connectors described in this report comply with, or are suitable alternatives to what is specified in, those codes listed in Section 1.0 of this report, subject to the following conditions:

- 5.1 The connectors must be manufactured, identified and installed in accordance with this report and the manufacturer's published installation instructions. A copy of the manufacturer's published installation instructions must be available at the jobsite at all times during installation. In the event of a conflict between this report and the manufacturer's published installation instructions, this report governs.
- 5.2 Calculations showing compliance with this report must be submitted to the code official. The calculations must be prepared by a registered design professional where required by the statutes of the jurisdiction in which the project is to be constructed.
- 5.3 Connected wood members and fasteners must comply with Sections 3.8.2, 3.8.3, and 3.8.4, as applicable.
- 5.4 Adjustment factors, noted in Section 4.1 of this report and the applicable codes, must be considered in the design of the connections where applicable.
- 5.5 Use of connectors and fasteners with preservative-treated or fire-retardant-treated lumber must be in accordance with Section 3.8.4.

6.0 EVIDENCE SUBMITTED

Data in accordance with the [ICC-ES Acceptance Criteria for Joist Hangers and Similar Devices \(AC13\)](#), approved October 2018 (editorially revised February 2024).

7.0 IDENTIFICATION

- 7.1 Each connector described in this report is identified by the product model (stock) number, the number of the ICC-ES index evaluation report for MiTek ([ESR-2685](#)), and by one or more of the following designations: MiTek, USP or USP Structural Connectors.

7.2 The report holder’s contact information is the following:

MITEK INC.
16023 SWINGLEY RIDGE ROAD
CHESTERFIELD, MISSOURI 63017
(800) 328-5934
www.mitek-us.com
uspcustomerservice@mii.com

TABLE 1—CSH-TZ CONCEALED STRINGER HANGER

STOCK NO.	STEEL GAGE	DIMENSIONS (in.)				FASTENER SCHEDULE					ALLOWABLE LOADS (lbs) ^{1,2,3}		
		JOIST WIDTH	HANGER			Rim/Band Joist		Stringer			Download		
			W	H	D	Qty	Type	Wide Face Qty	Narrow Face Qty	Type	C _D = 1.0	C _D = 1.15	C _D = 1.25
CSH-TZ	18	1½	1 ⁷ / ₁₆	5	5	8	10d x 1½	4	1	10d x 1½	875	875	875

For **SI**: 1 inch = 25.4 mm, 1 lbf = 4.45 N, 1 psi = 6.895 kPa.

¹Allowable loads have been adjusted for load duration factors, C_D, as shown, in accordance with the NDS. The allowable loads do not apply to loads of other durations and are not permitted to be adjusted for other load durations. See Sections 4.1 and 4.2 for additional design and installations requirements.

²Allowable loads shown are for installations in wood members complying with Section 3.8.2 and are based on the use of wood members with a reference compression perpendicular to grain design value, F_{c-perp}, of 625 psi or greater.

³The CSH-TZ is designed to support stair stringers and has not been torsionally tested for support of floor and roof framing members.

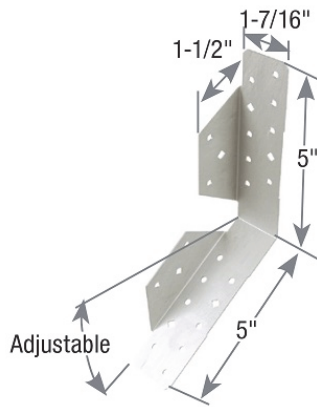

CSH-TZ Concealed Stringer Hanger



Typical CSH-TZ Installation

FIGURE 1—CSH-TZ CONCEALED STRINGER HANGER

TABLE 2—HDQIF INVERTED FLANGE FACE MOUNT HANGER ⁴

STOCK NO.	STEEL GAGE	DIMENSIONS (in.)			FASTENER SCHEDULE ²				ALLOWABLE LOADS (lbs) ^{1,3,4}			
					HEADER		JOIST		Download			Uplift
		W	H	D	Qty	Type	Qty	Type	C _D = 1.0	C _D = 1.15	C _D = 1.25	C _D = 1.6
HDQ179IF	14	1 ¹³ / ₁₆	9	3	8	WS3	4	WS15	3340	3605	3605	1140
HDQ17112IF	14	1 ¹³ / ₁₆	11	3	10	WS3	6	WS15	3605	3605	3605	1520
HDQ1714IF	14	1 ¹³ / ₁₆	13 ³ / ₈	3	12	WS3	6	WS15	4660	4840	4840	1995
HDQ310IF	14	2 ⁹ / ₁₆	9	3	8	WS3	4	WS15	3340	3605	3605	1140
HDQ210-2IF	14	3 ¹ / ₄	9	3	12	WS3	6	WS3	5015	5145	5145	2975
HDQ410IF	14	3 ⁹ / ₁₆	9	3	12	WS3	6	WS3	5015	5145	5145	2975
HDQ412IF	14	3 ⁹ / ₁₆	11	3	14	WS3	6	WS3	5605	5605	5605	3280
HDQ210-3IF	14	4 ⁵ / ₈	9	3	12	WS3	6	WS3	5015	5145	5145	2975
HDQ5210IF	14	5 ¹ / ₄	9	3	12	WS3	6	WS3	5015	5145	5145	2975
HDQ5212IF	14	5 ¹ / ₄	11	3	14	WS3	6	WS3	5605	5605	5605	3280
HDQ610IF	14	5 ¹ / ₂	9	3	12	WS3	6	WS3	5015	5145	5145	2975
HDQ612IF	14	5 ¹ / ₂	11	3	14	WS3	6	WS3	5605	5605	5605	3280

For **SI**: 1 inch = 25.4 mm, 1 lbf = 4.45 N, 1 psi = 6.895 kPa.

¹Allowable loads have been adjusted for load duration factors, C_D, as shown, in accordance with the NDS. The allowable loads do not apply to loads of other durations and are not permitted to be adjusted for other load durations. See Sections 4.1 and 4.2 for additional design and installations requirements.

²Wood screws (WS) used for HDQIF hangers are described in [ESR-2761](#) and are included with the hangers.

³Allowable loads shown are for installations in wood members complying with Section 3.8.2 and are based on the use of wood members with a reference compression perpendicular to grain design value, F_{c-perp}, of 625 psi or greater.

⁴HDQIF hangers provide torsional resistance, where torsional resistance is defined as a moment not less than 75 pounds (334 N) times the depth of the hanger, at which the lateral movement of the top or bottom of the joist with respect to the vertical position of the joist is 0.125 inch (3.2 mm).

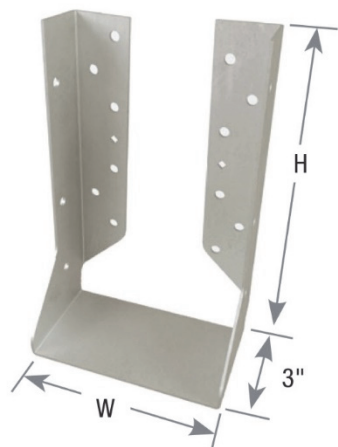

HDQIF Inverted Flange Face Mount Hanger



Typical HDQIF Installation

FIGURE 2—HDQIF INVERTED FLANGE FACE MOUNT HANGER

TABLE 3—HTC HEAVY TRUSS DEFLECTION CLIP

STOCK NO.	STEEL GAGE	DIMENSIONS (in.)				FASTENER SCHEDULE				ALLOWABLE LOADS (lbs) ^{1,2}					
						Plate		Truss/Rafter Qty	Type	Without Gap ³			With 1 1/4" Gap ³		
		W	H	L	D	Top Qty	Side Qty			F1	F2	F3	F1	F2	F3
HTC4	16	3 1/2	3 1/4	1 15/16	1	2	4	3	10dx1 1/2	C _D = 1.6					
										655	450	220	235	285	115

For SI: 1 inch = 25.4 mm, 1 lbf = 4.45 N, 1 psi = 6.895 kPa.

¹Allowable loads have been adjusted for load duration factors, C_D, as shown, in accordance with the NDS. The allowable loads do not apply to loads of other durations and are not permitted to be adjusted for other load durations. See Sections 4.1 and 4.2 for additional design and installations requirements.

²Allowable loads shown are for installations in wood members complying with Section 3.8.2 and are based on the use of wood members with a reference compression perpendicular to grain design value, F_{c-perp}, of 625 psi or greater.

³Truss/rafter must be bearing on the top plate to achieve the allowable loads under "Without Gap". When installed with maximum 1 1/4" space between truss/rafter and top plate, use loads under "With 1 1/4" Gap".

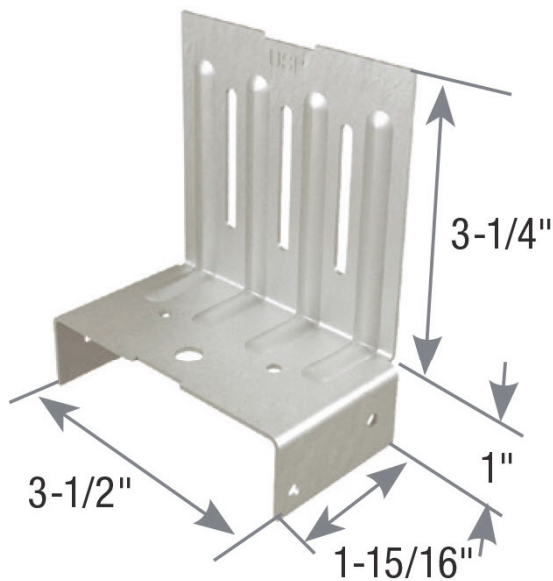

HTC4 Heavy Truss Deflection Clip

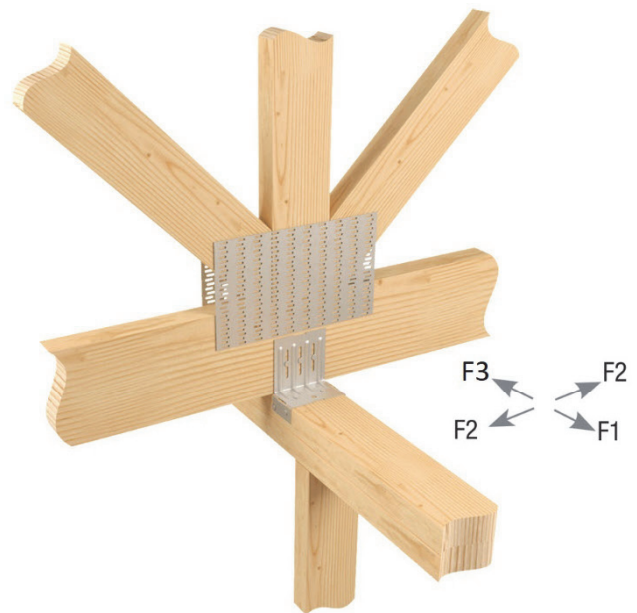

Typical HTC4 installation

FIGURE 3—HTC HEAVY TRUSS DEFLECTION CLIP

TABLE 4—JDS PURLIN HANGER

STOCK NO.	STEEL GAGE	DIMENSIONS (in.)				PURLIN(S)		MIN/MAX	FASTENER SCHEDULE ²					ALLOWABLE LOADS (lbs) ^{1,3,4}			
		W	H	D	TF	Qty	Nom. Size		Header			Joist		Download			Uplift
									Qty Top	Qty Face	Type	Qty	Type	C _D = 1.0	C _D = 1.15	C _D = 1.25	C _D = 1.6
JDS24 S	18	1 ⁹ / ₁₆	3 ¹ / ₂	1 ¹ / ₄	3 ³ / ₄	1	2 x 4	Min	2	2	10d x1 ¹ / ₂	2	10d x1 ¹ / ₂	500	500	500	325
								Max	2	0		2	10d Com.	575	605	625	450
JDS26 S	18	1 ⁹ / ₁₆	5 ¹ / ₂	1 ¹ / ₄	3 ³ / ₄	1	2 x 6	Min	2	2	10d x1 ¹ / ₂	4	10d x1 ¹ / ₂	615	615	615	420
								Max	2	0		4	10d Com.	775	830	870	745
JDS24	18	1 ⁹ / ₁₆	3 ¹ / ₂	1 ¹ / ₄	1 ⁹ / ₁₆	2	2 x 4	Min	2	2	10d x1 ¹ / ₂	2	10d x1 ¹ / ₂	1000	1000	1000	370
								Max	4	0		2	10d Com.	1185	1245	1285	900
JDS26	18	1 ⁹ / ₁₆	5 ¹ / ₂	1 ¹ / ₄	1 ⁹ / ₁₆	2	2 x 6	Min	2	2	10d x1 ¹ / ₂	4	10d x1 ¹ / ₂	1235	1235	1235	740
								Max	4	0		4	10d Com.	1575	1695	1775	1490
JDS26-175	18	1 ⁹ / ₁₆	5 ⁷ / ₁₆	1 ¹ / ₄	1 ³ / ₄	2	2 x 6	Min	2	2	10d x1 ¹ / ₂	4	10d x1 ¹ / ₂	1235	1235	1235	740
								Max	4	0		4	10d Com.	1675	1790	1870	1490

For SI: 1 inch = 25.4 mm, 1 lbf = 4.45 N, 1 psi = 6.895 kPa.

¹Allowable loads have been adjusted for load duration factors, C_D, as shown, in accordance with the NDS. The allowable loads do not apply to loads of other durations and are not permitted to be adjusted for other load durations. See Sections 4.1 and 4.2 for additional design and installations requirements.

²Fastener schedule includes options for minimum (Min) and maximum (Max) allowable loads. The joist hangers are not intended for use with intermediate numbers of fasteners.

³Allowable loads shown are for installations in wood members complying with Section 3.8.2 and are based on the use of wood members with a reference compression perpendicular to grain design value, F_{c-perp}, of 625 psi or greater.

⁴JDS hangers provide torsional resistance, where torsional resistance is defined as a moment not less than 75 pounds (334 N) times the depth of the hanger, at which the lateral movement of the top or bottom of the joist with respect to the vertical position of the joist is 0.125 inch (3.2 mm).

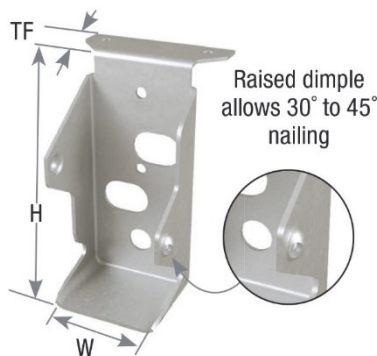

JDS24S Purlin Hanger



Typical JDS26S Single-Sided Installation



Typical JDS26 / JDS26-175 Installation

FIGURE 4—JDS PURLIN HANGER

TABLE 5—JLIF-TZ INVERTED FLANGE JOIST HANGER

STOCK NO.	STEEL GAGE	DIMENSIONS (in.)			FASTENER SCHEDULE				ALLOWABLE LOADS (lbs) ^{1,2,3}			
					HEADER		JOIST		Download			Uplift
		W	H	D	Qty	Type	Qty	Type	C _D = 1.0	C _D = 1.15	C _D = 1.25	C _D = 1.6
JL24-IF	18	1 ⁹ / ₁₆	3 ¹ / ₈	1 ¹ / ₂	4	10d Common	2	10dx1 ¹ / ₂	480	545	590	265
						16d Common			570	600	600	265
JL26-IF	18	1 ⁹ / ₁₆	4 ¹ / ₂	1 ¹ / ₂	6	10d Common	4	10dx1 ¹ / ₂	720	820	885	740
						16d Common			860	975	1060	740
JL28-IF	18	1 ⁹ / ₁₆	6 ¹ / ₈	1 ¹ / ₂	8	10d Common	4	10dx1 ¹ / ₂	960	1095	1180	740
						16d Common			1145	1195	1195	740
JL210-IF	18	1 ⁹ / ₁₆	8 ¹ / ₄	1 ¹ / ₂	11	10d Common	6	10dx1 ¹ / ₂	1320	1505	1625	1115
						16d Common			1575	1785	1940	1115

For SI: 1 inch = 25.4 mm, 1 lbf = 4.45 N, 1 psi = 6.895 kPa.

¹Allowable loads have been adjusted for load duration factors, C_D, as shown, in accordance with the NDS. The allowable loads do not apply to loads of other durations and are not permitted to be adjusted for other load durations. See Sections 4.1 and 4.2 for additional design and installations requirements.

²Allowable loads shown are for installations in wood members complying with Section 3.8.2 and are based on the use of wood members with a reference compression perpendicular to grain design value, F_{c-perp}, of 625 psi or greater.

³JLIF-TZ hangers provide torsional resistance, where torsional resistance is defined as a moment not less than 75 pounds (334 N) times the depth of the hanger, at which the lateral movement of the top or bottom of the joist with respect to the vertical position of the joist is 0.125 inch (3.2 mm).

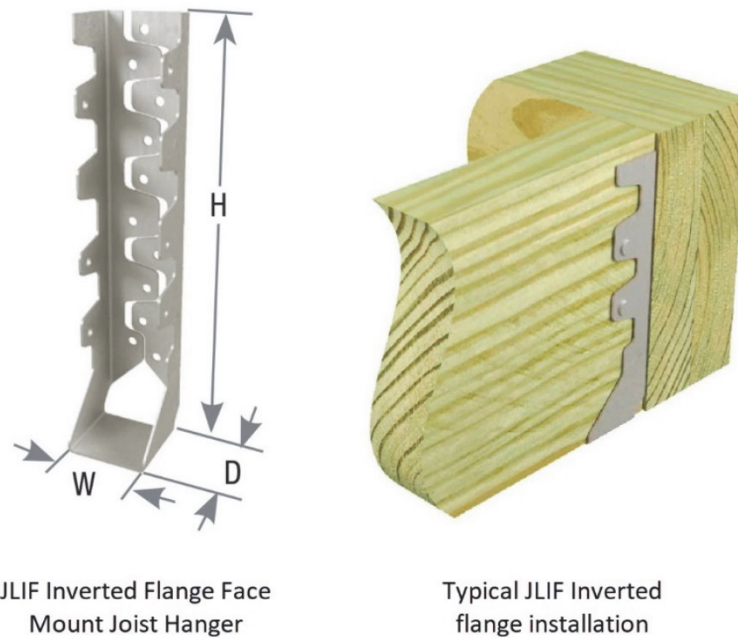

JLIF Inverted Flange Face Mount Joist Hanger

Typical JLIF Inverted flange installation

FIGURE 5—JLIF-TZ INVERTED FLANGE JOIST HANGER

TABLE 6—MUS SLANT NAIL JOIST HANGERS

STOCK NO.	STEEL GAGE	DIMENSIONS (in.)		FASTENER SCHEDULE				ALLOWABLE LOADS (lbs) ^{2,3,4}			
				HEADER		JOIST ¹		Download			Uplift
		W	H	Qty	Type	Qty	Type	C _D = 1.0	C _D = 1.15	C _D = 1.25	C _D = 1.6
MUS26	18	1 ⁹ / ₁₆	5 ¹ / ₁₆	6	10d Common	6	10d Common	1310	1495	1620	865
MUS28	18	1 ⁹ / ₁₆	7 ¹ / ₁₆	8	10d Common	8	10d Common	1745	1995	2160	1230

For SI: 1 inch = 25.4 mm, 1 lbf = 4.45 N, 1 psi = 6.895 kPa.

¹Joist nails must be driven horizontally into the joist at an angle of 30- to 45-degrees from normal, such that they penetrate through the joist and into the header.

²Allowable loads have been adjusted for load duration factors, C_D, as shown, in accordance with the NDS. The allowable loads do not apply to loads of other durations and are not permitted to be adjusted for other load durations. See Sections 4.1 and 4.2 for additional design and installations requirements.

³Allowable loads shown are for installations in wood members complying with Section 3.8.2 and are based on the use of wood members with a reference compression perpendicular to grain design value, F_{c-perp}, of 625 psi or greater.

⁴MUS hangers provide torsional resistance, where torsional resistance is defined as a moment not less than 75 pounds (334 N) times the depth of the hanger, at which the lateral movement of the top or bottom of the joist with respect to the vertical position of the joist is 0.125 inch (3.2 mm).

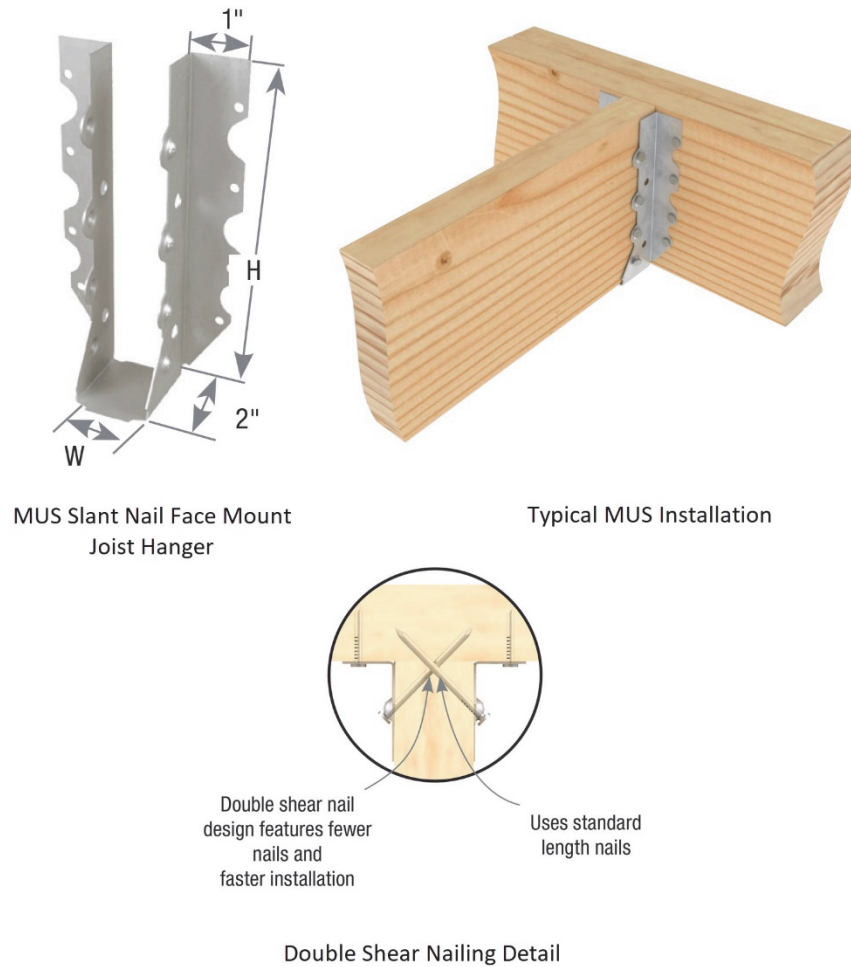

FIGURE 6—MUS SLANT NAIL JOIST HANGERS

TABLE 7—RBC ROOF BOUNDARY CLIP

STOCK NO.	STEEL GAGE	DIMENSIONS (in.)		FASTENER SCHEDULE				ALLOWABLE LOADS (lbs) ^{1,2,3,4}			
				Top Plate		Blocking		Load Direction: F1			
		W	H	Qty	Type	Qty	Type	C _D = 1.0	C _D = 1.15	C _D = 1.25	C _D = 1.6
RBC	20	4½	6	6	10dx1½	6	10dx1½	505	505	505	505

For SI: 1 inch = 25.4 mm, 1 lbf = 4.45 N, 1 psi = 6.895 kPa.

¹Allowable loads have been adjusted for load duration factors, C_D, as shown, in accordance with the NDS. The allowable loads do not apply to loads of other durations and are not permitted to be adjusted for other load durations. See Sections 4.1 and 4.2 for additional design and installations requirements.

²Allowable loads shown are for installations in wood members complying with Section 3.8.2 and are based on the use of wood members with a reference compression perpendicular to grain design value, F_{c-perp}, of 625 psi or greater.

³Refer to Figure 7 for installation configurations.

⁴RBC is field adjustable from 0° to 45°. Bend angle only once.

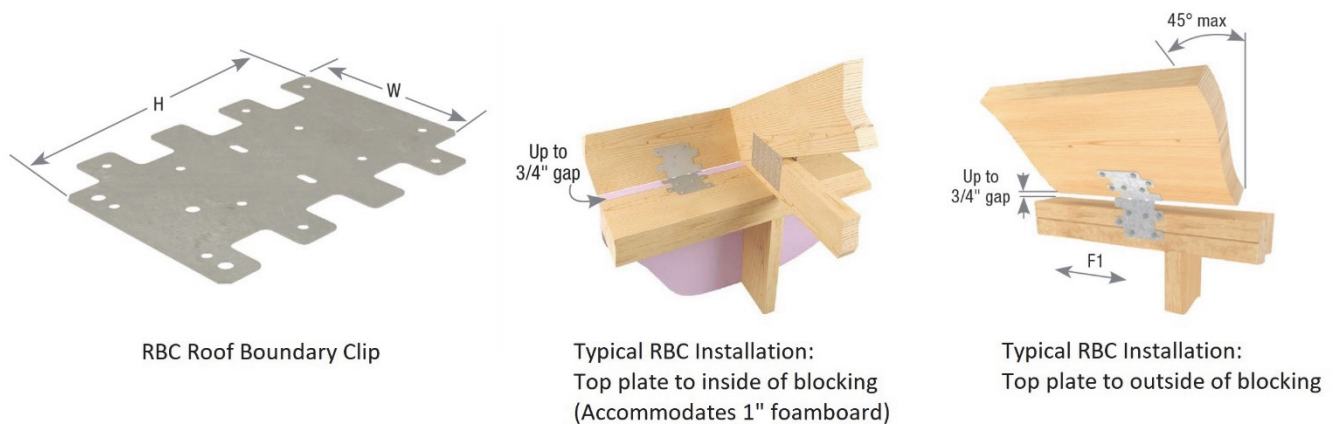

FIGURE 7—RBC ROOF BOUNDARY CLIP

TABLE 8—STEEL TYPE, STRENGTH AND CORROSION RESISTANCE

PRODUCT	GAGE	STEEL	COATING ¹
CSH-TZ Concealed Stringer Hanger	18	ASTM A653, SS designation, Grade 40	G185
HDQIF Inverted Flange Face Mount Hangers	14	ASTM A653, SS designation, Grade 40	G90
HTC Heavy Truss Deflection Clip	16	ASTM A653, SS designation, Grade 40	G90
JDS Purlin Hangers	18	ASTM A653, SS designation, Grade 40	G90
JLIF-TZ Inverted Flange Face Mount Hangers	18	ASTM A653, SS designation, Grade 40	G185
MUS Slant Nail Face Mount Joist hanger	18	ASTM A653, SS designation, Grade 40	G90
RBC Roof Boundary Clip	20	ASTM A653, SS designation, Grade 40	G90

¹Corrosion protection in accordance with ASTM A653.

DIVISION: 06 00 00—WOOD, PLASTICS AND COMPOSITES
Section: 06 05 23—Wood, Plastic, and Composite Fastenings

REPORT HOLDER:

MITEK® INC.

EVALUATION SUBJECT:

MITEK STRUCTURAL CONNECTORS FOR WOOD FRAME CONSTRUCTION

1.0 REPORT PURPOSE AND SCOPE**Purpose:**

The purpose of this evaluation report supplement is to indicate that MiTek Structural Connectors for Wood Frame Construction, described in ICC-ES evaluation report [ESR-4517](#), have also been evaluated for compliance with the codes noted below as adopted by the Los Angeles Department of Building and Safety (LADBS).

Applicable code editions:

- 2023 *City of Los Angeles Building Code* (LABC)
- 2023 *City of Los Angeles Residential Code* (LARC)

2.0 CONCLUSIONS

The MiTek Structural Connectors for Wood Frame Construction, described in Sections 2.0 through 7.0 of the evaluation report [ESR-4517](#), comply with the LABC Chapter 23, and the LARC, and are subject to the conditions of use described in this supplement.

3.0 CONDITIONS OF USE

The MiTek Structural Connectors for Wood Frame Construction described in this evaluation report supplement must comply with all of the following conditions:

- All applicable sections in the evaluation report [ESR-4517](#).
- The design, installation, conditions of use and identification of the MiTek structural connectors are in accordance with the 2021 *International Building Code*® (IBC) provisions noted in the evaluation report [ESR-4517](#).
- The design, installation and inspection are in accordance with additional requirements of LABC Chapters 16, 17 and 23, as applicable.
- Allowable loads in tables are for the wood fastening devices and its fasteners. The connected member shall be checked for capacity (which may govern).
- Solid blocking must be required for all joist hangers supporting roof joists having one end twisted more than one-half degree per foot of length relative to the other end, except as specifically noted in the evaluation report [ESR-4517](#).
- The supported end of joist or beam must be within ¼-inch from the supporting member.
- Under the LARC, an engineered design in accordance with LARC Section R301.1.3 must be submitted.

This supplement expires concurrently with the evaluation report, reissued January 2024 and revised May 2024.

DIVISION: 06 00 00—WOOD, PLASTICS AND COMPOSITES
Section: 06 05 23—Wood, Plastic, and Composite Fastenings

REPORT HOLDER:

MITEK® INC.

EVALUATION SUBJECT:

MITEK STRUCTURAL CONNECTORS FOR WOOD FRAME CONSTRUCTION

1.0 REPORT PURPOSE AND SCOPE**Purpose:**

The purpose of this evaluation report supplement is to indicate that the MiTek Structural Connectors for Wood Construction, described in ICC-ES evaluation report ESR-4517, have also been evaluated for compliance with the codes noted below.

Applicable code editions:

- 2023 and 2020 *Florida Building Code—Building*
- 2023 and 2020 *Florida Building Code—Residential*

1.0 CONCLUSIONS

The MiTek Structural Connectors for Wood Frame Construction, described in Sections 2.0 through 7.0 of the ICC-ES evaluation report ESR-4517, comply with the *Florida Building Code—Building* and the *Florida Building Code—Residential*, provided the design requirements are determined in accordance with the *Florida Building Code—Building* or the *Florida Building Code—Residential*, as applicable. The installation requirements noted in ICC-ES evaluation report ESR-4517 for the 2021 and 2018 *International Building Code*® meet the requirements of the *Florida Building Code—Building* or the *Florida Building Code—Residential*, as applicable.

Use of the MiTek Structural Connectors for Wood Frame Construction has also been found to be in compliance with the High-Velocity Hurricane Zone provisions of the *Florida Building Code—Building* and the *Florida Building Code—Residential*, and the following conditions apply:

- a. For connections subject to uplift, the connection must be designed for no less than 700 pounds (3114 N).
- b. Fasteners must be galvanized.

For products falling under Florida Rule 61G20-3, verification that the report holder's quality assurance program is audited by a quality assurance entity approved by the Florida Building Commission for the type of inspections being conducted is the responsibility of an approved validation entity (or the code official, when the report holder does not possess an approval by the Commission).

This supplement expires concurrently with the evaluation report, reissued January 2024, and revised May 2024.