

It is a common practice in post-frame buildings to have a knee brace specified to provide overall building stability to the post-frame system. When a knee brace is called for, it is typically noted in two ways. The first would consist of a brace at a given angle, and a total axial force in the brace. Often a brace will be specified and the axial brace force will be broken down into its horizontal and vertical components. When it is not given in individual components, some math is necessary to determine the appropriate loads to be placed on the truss. An example will follow:

Given: Knee-brace at 30 degrees from vertical. Total axial force is 2500# (see figure 1).

Solution: Use trigonometry to determine loads (see figure 2).

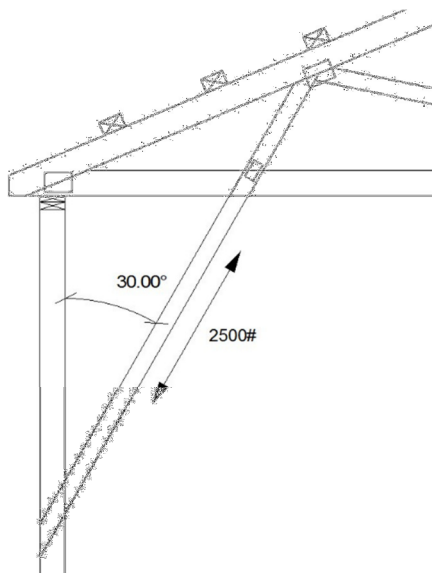

*Figure 1 - Knee-Brace Diagram*

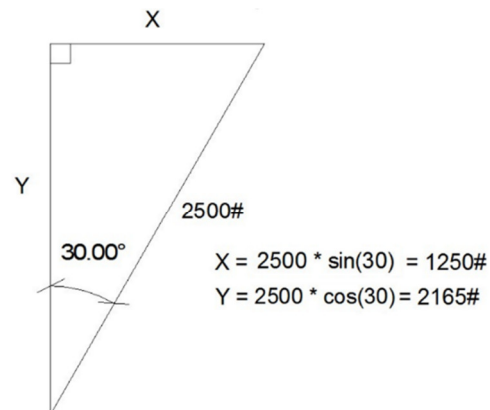

*Figure 2 - Trigonometric Functions*

Once the math has been figured, start the truss design by inserting a web at the appropriate angle and location, such that the truss web will align with the knee-brace. After doing so, enter special loading. In special loading, each respective wind left and right load cases will need to be modified.

The wind left load case is defined as wind moving from left to right. When exposed to this loading condition, the knee brace on the left end of the truss will pull on the truss, thus causing a 2165# downward load, and 1250# leftward load. Scroll to the “Wind Left” load case, click “Edit this load case only” in the lower left portion of the dialogue box. You can then click “new load”. You will enter the proper distance to the load, its magnitude, direction, and which chord is to be loaded.

See figures 3, 4, and 5.

# Knee-Brace Loading

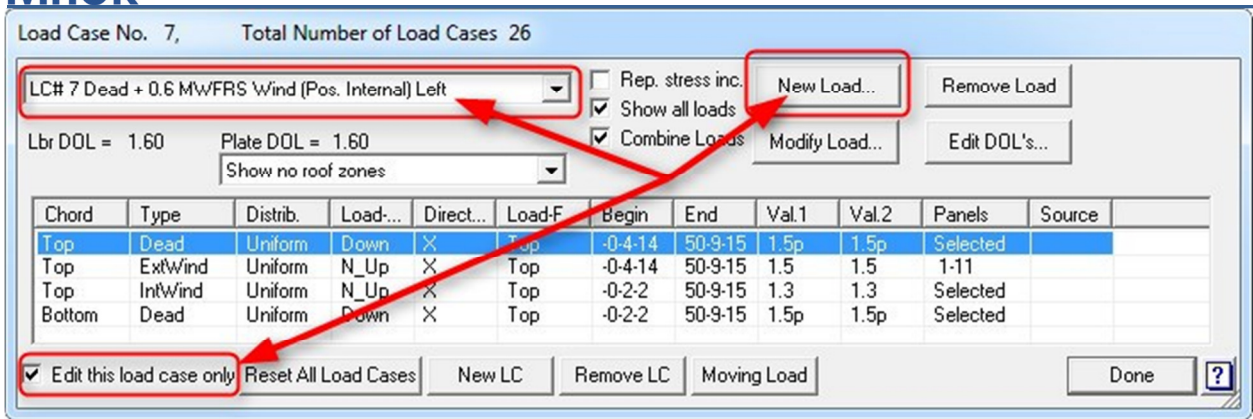

Figure 3 - Wind Left Selections

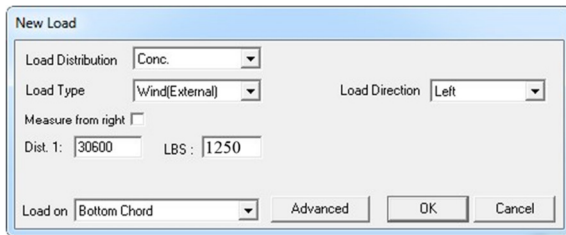

Figure 4 - Left Load



Figure 5 - Down Load

Once the wind left load case(s) have been loaded, it is necessary to repeat this process to load the opposite side of the truss (if a knee-brace is specified on both sides). To do this, use the same loading selections; however the vertical loading direction will be flipped (the horizontal loading direction remains static). The brace will be pushing on the right side of the truss for upward and leftward loads.

Continuing, this process will be repeated for the wind right load case(s), adjusting the load direction accordingly. Please see figure 6 below for a chart which specifies load directions for each wind loading condition.

	Left Brace		Right Brace	
Wind Left	Down	Left	Up	Left
Wind Right	Up	Right	Down	Right

Figure 6 - Load Direction Chart

For additional information, or if you have questions, please contact the MiTek Engineering department.