

MiTek Engineering software is a powerful tool used for the design of Metal Plate Connected Wood Trusses and Building Design that greatly increases the accuracy and the efficiency of the design process. However, it must always be remembered that MiTek Engineering software is just that, a tool. Neither it nor any other software program can take the place of an experienced designer. Designs should always be reviewed before putting into production. Trusses designed following the guidelines outlined below can normally be sealed as shown on the output. Trusses falling outside these limits may be sealable as well but should be reviewed by an experienced truss engineer before fabrication.

Floor Trusses

- Maximum span to depth ratio of 20 (for example, a 14" deep truss should not exceed a span of 23' 4").
- Maximum 30" (2' 6") top chord panel length on flat-wise trusses.
- Maximum 48" (4') top chord panel length on edgewise trusses.
- Minimum duct chase offset from the bearing is $\frac{1}{4}$ of the truss span.
- No duct chase opening in cantilever sections.
- Maximum cantilever is 4 times the depth of the truss or $\frac{1}{3}$ the length of the truss.
- Maximum cantilever without a concentrated load at the end is 4 times the depth of the truss.
- DOL (duration of load) for plate and lumber design cannot be set above 1.00.
- Deflection limits cannot be less than $L/360$ LL (live load) + $L/240$ TL (total load); the higher the number on the bottom of the fraction, the stiffer the truss.
- Deflection settings for cantilever are half that of the main span.
- No splices in chase openings.
- Trusses used for an office application must be designed with the 2000 lb Moving Office Load (safe load) and minimum 50 psf live load. Also, provisions for uniformly distributed live load of minimum 15 psf ("partition load") shall be made, unless specified live load exceeds 80 psf.
- Stacked top chords for the purposes of having a change in floor elevation in the course of the truss length should run at least one panel back for each level of chord decrease. If the change in elevation exceeds 3", a "K" webs should be used.

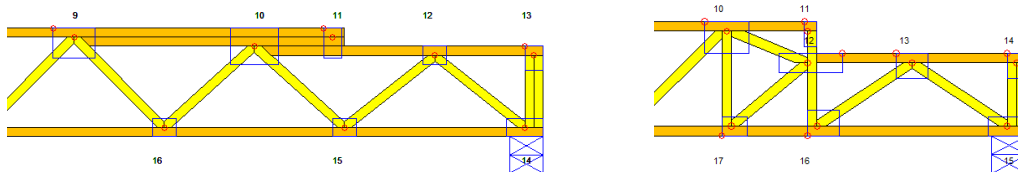

- Do not splice in end panel of top chord when truss is top chord bearing.
- Trimmable end trusses must be ran using software feature or test runs must be made manually.
- Apply appropriate reductions for treated lumber and stainless steel plates. Stainless steel plates have 25% lower yield strength than regular MiTek MT20 plates. The best

option to handle these reductions is to use MT20SS plates, the program automatically applies all the necessary reductions.

- Make sure that it is possible to transfer the concentrated loads through all plies of a girder.

Roof Trusses

- Do not break truss triangulation by removing webs. Maximum span truss with un-triangulated heels 20'0".
- Scissor truss slope differentials between top and bottom chords must be greater than or equal to 2/12
- Maximum span to depth ratio is 24 for parallel chord roof trusses (For example, a 24" deep parallel chord roof truss should not exceed a span of 48').
- Valleys and Piggyback Trusses must have verticals 4' o.c. or close to it in odd panel.
- Limit number of girder plies to 5; however, 6 plies are allowed if load is tying in from both sides of the truss.
- Increase dead loads to include the self-weight of the truss if needed. This is normally applicable to multi-ply girders.
- 100' maximum span without early PE involvement and building engineer.
- Maximum overhang lengths: 2x4=3.0', 2x6=5.0'
- Lumber Requirements:
 - Minimum No.2 for all chords on trusses over 8' long, excluding verticals.
 - Permissible to use lower grades on bottom chords of valleys, piggybacks and continuously supported gables.
 - 2x3 minimum web size.
- Bearings:
 - Minimum bearing size is 1-1/2".
 - No "Pinned-Pinned" trusses without special considerations.
 - No off-joint bearing unless bearing is considered a separate joint labeled with a joint number.

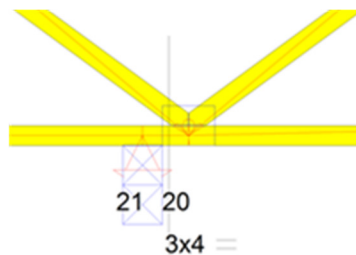

- No splice at an off-joint bearing
- Eliminate or limit uplift in gravity load cases to 1000lbs. If the outside bearing has high uplift, you can try to eliminate the uplift by removing the outside bearing and running the truss as a cantilever or using the **Release bearing** feature on the bearing with the high uplift.

- Do not neglect warning “**Required bearing size at joint(s)... greater than input bearing size**” in the general note section of the Truss Design Drawing. If insufficient bearing occurs, increase bearing size, check the capacity with a bearing enhancer, or investigate other possibilities such as running a vertical through or changing the bottom chord lumber. Pay attention to what the bearing is, as the crushing problem may be eliminated for the truss but not the bearing supporting the truss.
- Shear plate required on all notched bearing for ledger details with reactions over 500lbs x DOL as shown below (program applies shear plate automatically if end vertical analyzed as “top chord”):

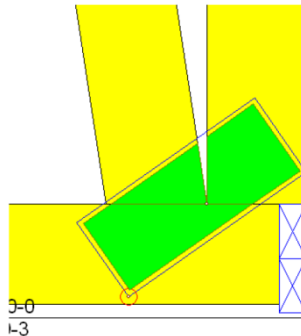

- Minimum heel height with leg-down = 12” (requires two joints).
- Member above a top chord bearing must be labeled as a block and the vertical next to it must be a top chord.

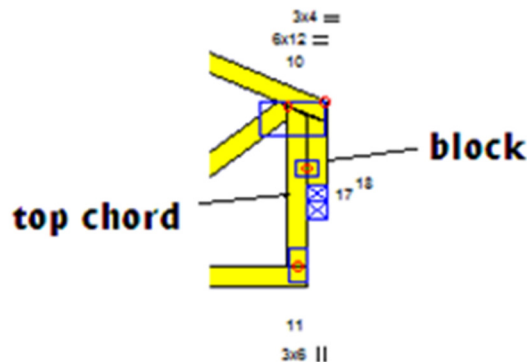

- No tie-in trusses at bearing block locations.
- Deflection Limits
 - Deflection limits cannot be less than $L/240$ LL (live load) + $L/180$ TL (total load).
 - Deflection settings for cantilever and overhang are half that of the main span.
 - Horizontal total load deflection = 1.25” without special consideration. Residential jobs should not exceed 1.25”
 - Horizontal live load deflection = 0.75” without special consideration. Residential jobs should not exceed 0.75”
 - Try to limit vertical total load deflection to 2.0”, unless it is agricultural truss.

- Attics

- Limit attic room bottom chord L/d to max 23 (for example, attic truss with 2x10 bottom chord lumber in the room, should not have room wider than 17'-9").
- No top chord splices in haunch of attic room as shown below:

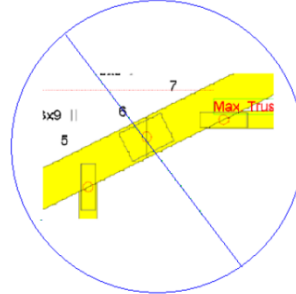

- No bottom chord splice directly over a bearing within a room.

- Plating

- Do not reduce minimum plating defaults. Truss design parameters, sent to MiTek engineers to be designed and sealed, are reanalyzed with MiTek minimums and a different plate may appear on the sealed drawing.
- Top chord blocks must be increased in length to add second plate as shown below:

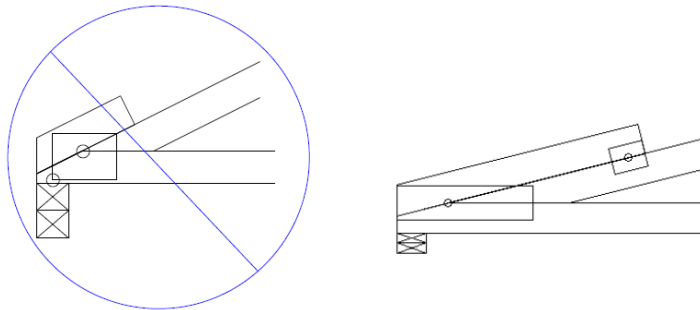

- Scabs and Stacked Chords

- If the ***“Special connection required between scab...”*** is printed in the Notes section of the engineering drawing, the scab connection is not adequate even though it is shown on the truss drawing. The scab length or type of fastener may need to be altered to try and eliminate the note. If note cannot be eliminated scab may not work and redesign of truss may be required.
- Scab must not extend past end of truss or scabbed member.

- See MiTek Technical Article [Truss Design with Treated Lumber or Corrosive Environments](#) for information on preservative treatments.

Please note that this list is not comprehensive. It is an attempt to address the most frequent problems that we encounter with Metal Plate Connected Wood Truss designs sent for seals. Each situation is unique and only an experienced truss designer/engineer can be the final authority on whether a design is acceptable; not a list. To preserve the conciseness of this list, explanations are intentionally left out. If you have questions, please contact the MiTek Engineering department.