



Scan the QR Code or select [this link](#) to access an instructional video that can assist with this procedure.



SERVICE BULLETIN

Document ID:

SB250

Title:

Installing New Saw Blade Motor and Hub

Affected machinery: BLADE wood processing system

Distribution: All customers with affected machinery

Applies to: All machines with the 6-bolt saw blade pattern

MiTek Automation
Phone: 800-523-3380
Fax: 636-328-9218
www.mitek-us.com

Copyright © 2024 MiTek®
All rights reserved.

Part # and Rev.	SB250 rev. C
Print Date	5 July 2024
Effectivity	All
Revision Date	05 July 2024
Revised By	A. McIntire
Orig. Release Date	26 September 2022
Created By	A. McIntire
Approved By	R. Tucker



CAUTION: The document should only be printed in color with adequate resolution. Graphics may be unclear and could create an unsafe condition if this recommendation is not followed.

NOTICE

Retain all packaging that was used to ship the contents of this service bulletin kit, and reuse for return shipment. The following parts **MUST be returned to MiTek:**

- **All obsolete components replaced as part of this procedure (old motor, hub, bushing, saw blade, and fasteners)**
- **All obsolete components ON HAND in your facility (old motors, hubs, bushings, saw blades, and fasteners)**

See Table 2 on page 14 for a detailed list of all components that must be returned.

All steps that reference parts that must be returned are colored red.

Purpose and Scope

This service bulletin instructs how to replace the motor and install the new hub, bushing, and saw blade in the BLADE wood processing system. These new and improved components will help your machine run more reliably and consistently moving into the future.

Overview

Parts Included

The parts included in this kit are shown in Table 1. Please make sure all parts and supplies are present before starting the procedure.

Table 1: Parts in SB250KIT

Quantity	Description	Part #
1	Motor	474176
1	Blade hub	76228
1	Bushing (includes hardware)	547258
1	Snap ring	379014
1	Saw blade, 17"	811071
1 box of 25	Saw blade bolts, 1" long	325188
1	Torque wrench, 3/8" drive, 30-250 in-lbs	814130
1	T40 Torx™ 3/8" bit	814131

Quantity	Description	Part #
1	Service bulletin document for motor and hub replacement	SB250

If you have any questions, call MiTek Automation Support at 1-800-523-3380.





Supplies Needed

- Torque wrench with capacity up to 220 in-lbs (torque wrench supplied)
- Socket Wrench
- T40 and T30 Torx™ bit compatible with wrenches (T40 bit supplied)
- 5-mm hex key socket for torque wrench
- 5/16 hex key
- Snap ring pliers
- Large screwdriver or small pry bar

Lockout/Tagout Procedure

Electrical Lockout/Tagout



 WARNING	
	<p>ELECTROCUTION HAZARD.</p> <p>All electrical work must be performed by a qualified electrician.</p> <p>Verify that all power to the machine has been turned off and follow approved lockout/tagout safety procedures before performing any maintenance.</p> <p>If it is absolutely necessary to troubleshoot an energized machine, follow NFPA 70E for proper procedures and person protective equipment.</p> <p>When the disconnect switch is off, there is still live power within the disconnect switch's enclosure. Always turn off the power at the building's power source to the equipment before opening this electrical enclosure.</p>

Before performing maintenance on any machine with electrical power, lockout/tagout the machine properly. When working on a machine outside of the machine's main electrical enclosure, not including work on the electrical transmission line to the machine, follow your company's approved lockout/tagout procedures which should include, but are not limited to the steps include in this service bulletin.

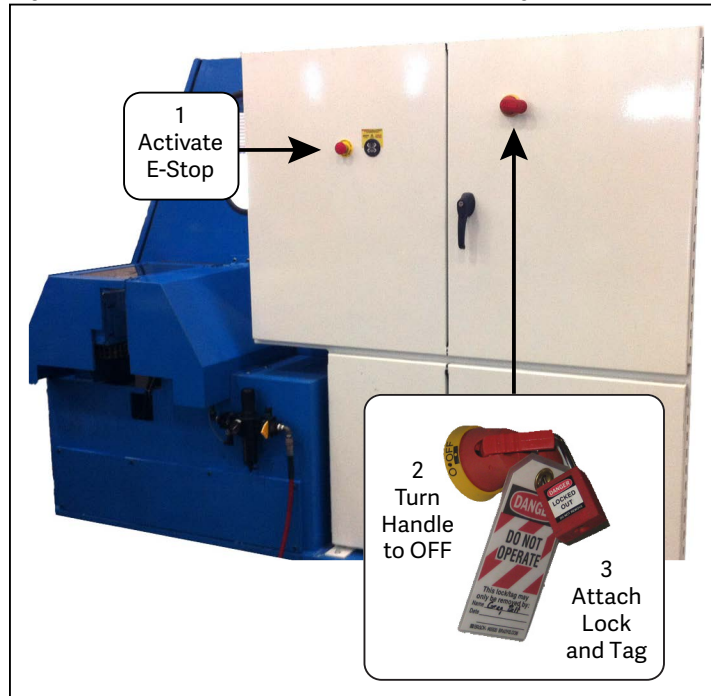
Figure 1: BLADE Disconnect Switch Lockout/Tagout Procedure





Pneumatic or Hydraulic System Lockout/Tagout

	 WARNING
	<p>HIGH PRESSURE HAZARD.</p> <p>Bleed pneumatic lines before performing any maintenance on the system.</p> <p>Working on pressurized lines may cause injury.</p>

After lockout/tagout of the electrical power, turn off or close the system's air shut-off valve and attach a lock and tag.

Procedure

Removing Saw Blade and Motor

	 WARNING
	<p>MOVING PARTS CAN CRUSH AND CUT.</p> <p>Always verify that power to the machine has been turned off and follow approved lockout/tagout procedures.</p>

1. Place the saw in Manual Mode using the switch on operator interface, and use the machine software to position the saw head to prepare for saw blade removal:
 - a) Rotate the angle of the saw blade so it is in a horizontal position (flat surface on top).
 - b) Adjust the elevation and stroke to a comfortable position for removing the blade and motor.

Figure 2: Saw Head Position for Saw Blade Removal

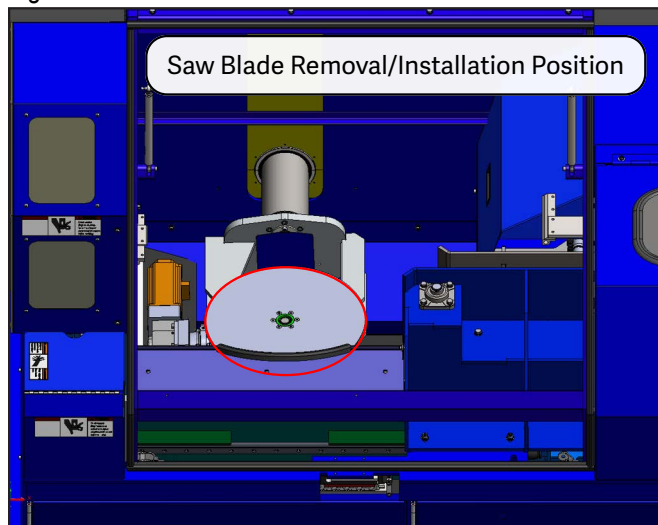

2. Press the **Request to Unlock** button next to the saw chamber door and open the door.
3. Shut down the touchscreen PC using **Power > Shutdown** in *Windows*.
4. Turn the disconnect switch handle on the main electrical enclosure to the OFF position. Lockout/tagout the machine. See Figure 1.



	 CAUTION
 	<p>CUT HAZARD.</p> <p>Saw blades are sharp. Wear gloves and eye protection when handling blade.</p>

5. Use socket wrench and T30 bit to loosen and remove the 6 bolts securing the saw blade (shown in red in Figure 3). **Set aside the 6 bolts for return shipment to MiTek.**

Figure 3: Bolts Securing Saw Blade

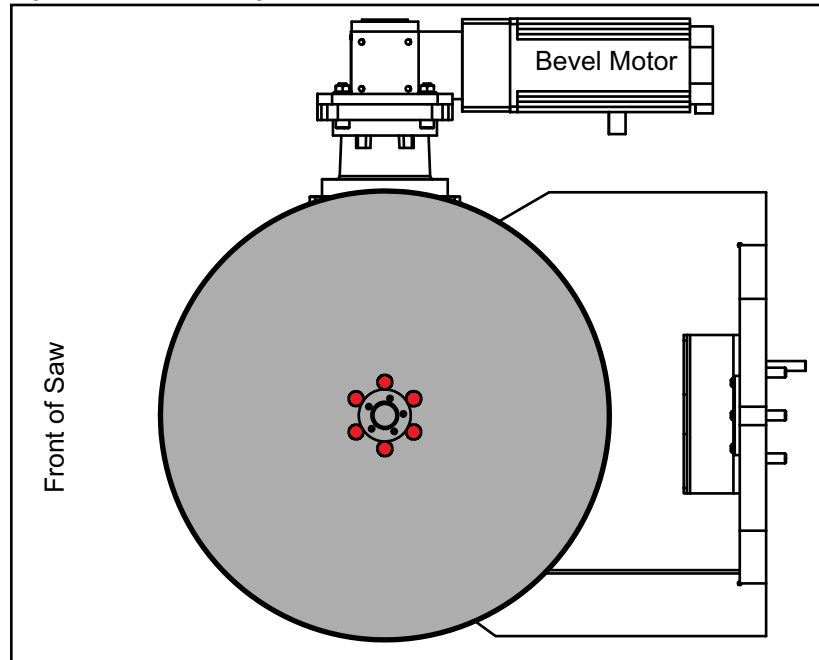

6. **Remove and set aside saw blade for return shipment to MiTek.** The old blade is NOT COMPATIBLE with the new saw head.
7. Close the saw chamber door.
8. Power on machine:
 - a) Remove lockout/tagout and switch the disconnect switch to the ON position. See Figure 1.
 - b) Release E-stop and press Reset switch on the operator interface.

Installing the New Motor

1. Use the machine software to position the saw head to prepare for motor removal.
 - a) Adjust the angle so that the motor is pointing upwards and the stroke so that the motor is close to the front of the saw chamber.

Figure 4: Saw Head Position for Motor Removal

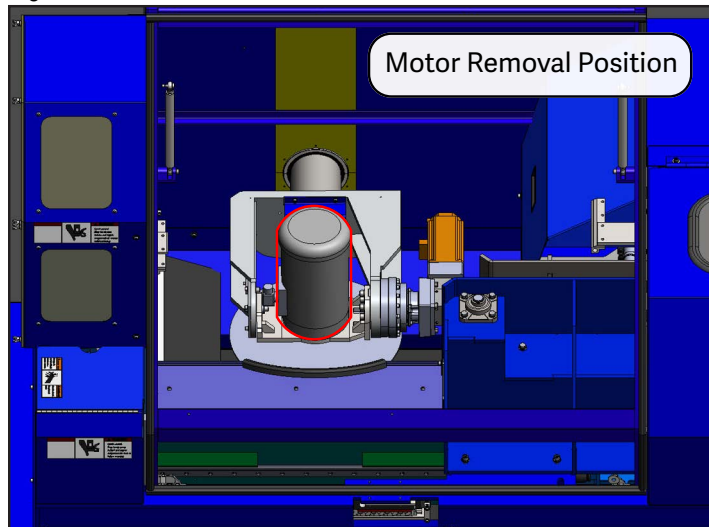

2. Activate an E-stop on the machine.
3. Press the **Request to Unlock** button next to the saw chamber door and open the door.
4. Shut down the touchscreen PC using **Power > Shutdown** in *Windows*.
5. Turn the disconnect switch handle on the main electrical enclosure to the OFF position and lockout/tagout the machine. See Figure 1.
6. Unscrew and disconnect the power cable from motor.

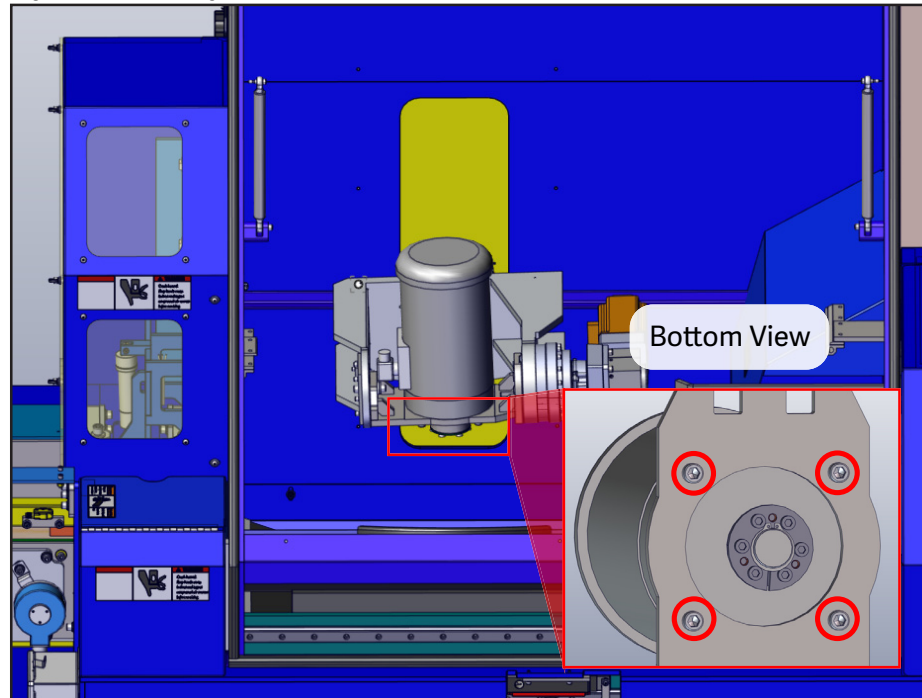

Figure 5: Motor Power Cable



7. Use the 5/16 hex key to remove the 4 bolts securing the motor shown in Figure 6 and remove the motor. Retain all bolts and washers for installing the new motor.

Figure 6: Removing Motor Bolts



8. **Set aside motor for return shipment to MiTek. Leave the hub, bushing, and snap ring attached to the motor as these must also be returned.**
9. Clean the motor mounting plate with a soft cloth and solvent to remove any sawdust or debris.
10. Place the new motor onto the motor mounting plate in the same orientation shown in Figure 6 (with the power connector on the left side). Use the 5/16 hex key to secure the motor with the 4 bolts and washers removed in step 7.
11. Reconnect the power cable to the motor. Screw the retaining ring down until it is tight. It should bottom out on the rubber seal on the matting. Pliers may be required to tighten correctly (see Figure 5).
12. Close the saw chamber door.
13. Power on machine:
 - a) Remove lockout/tagout and switch the disconnect switch to the ON position. See Figure 1.
 - b) Release E-stop and press Reset switch on the operator interface.
14. Use the machine software to position the saw head to for the installation of the hub and bushing (the motor shaft should be facing upwards).
15. Activate an E-stop on the machine.



16. Press the **Request to Unlock** button next to the saw chamber door and open the door.
17. Shut down the touchscreen PC using **Power > Shutdown** in *Windows*.
18. Turn the disconnect switch handle on the main electrical enclosure to the OFF position and lockout/tagout the machine. See Figure 1.
19. Follow the below instructions to prepare for assembly of the hub and bushing:
 - a) Clean motor shaft and hub bore with a solvent. It must be clean and dry before proceeding.
 - b) Locate a clean surface / environment for the assembly of hub and bushing.
 - c) Remove the bushing and hardware from its package. It is shipped pre-applied with a thin coating of machine oil. **DO NOT** remove or clean this oil as it is critical for proper functioning. If necessary, clean only with a clean, soft cloth. **Do NOT** use a solvent.
 - d) Verify that the radial slits in both sections of the bushing are in alignment (see Figure 7).
20. To prevent engagement during assembly of the hub and bushing, place 2 locking screws into the jacking holes and finger tighten (see Figure 7).
21. Place the hub and bushing onto the motor shaft in the order shown in Figure 7.



If the new bushing does not fit inside the hub or over the shaft, do not force it. Loosen the screws and pry the bushing pieces apart and then try again

22. Remove the two locking screws inserted in step 20 from the jacking holes.

Figure 7: Assembling and Aligning the Hub and Bushing

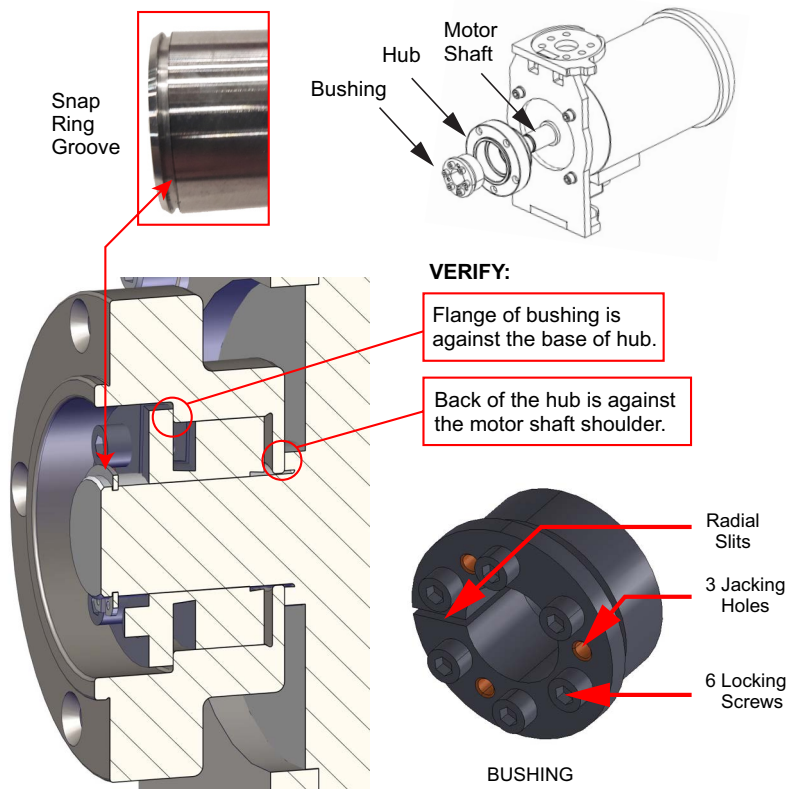

23. Tighten the 6 locking screws finger tight (see Figure 7).

24. Hold the hub still as shown in Figure 8.

- To hold hub in position, fasten two bolts to the saw hub. Use extra new saw blade bolts. Do NOT reuse these bolts on a saw blade!
- Position a large screwdriver or small pry bar between the two bolts, as shown in Figure 8.
- Hold the hub in place with a screwdriver or small pry bar.

Figure 8: Holding the Hub Still
(motor / hub shown outside saw chamber)





A torque wrench should be calibrated on a yearly basis to ensure accuracy.



How to check the torque after installation (between blade changes):

It is not necessary to re-torque the hub bushing bolts after initial installation unless the hub itself feels loose. If you feel it's necessary to check the torque on the hub bolts, only set the torque wrench to 156 in-lbs. If the bolts turn at 156 in-lbs, repeat all of step 25.

If the bolts do not turn at 156 in-lbs, no further action is needed.

25. Using a 5-mm hex socket, tighten the bushing bolts 1/4 turn at a time, using the phased method as described in Figure 9.

Figure 9: Tighten and Torque Bushing Bolts in This Order

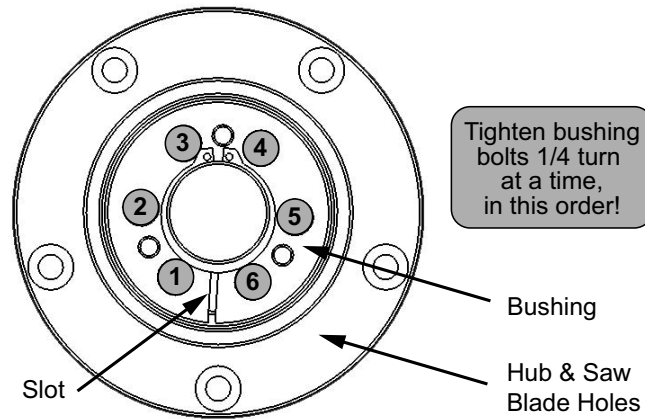

- Set the torque wrench to **164 in-lbs** (13.7 ft-lbs or 18.5Nm)
 - Beginning with bolt #1, tighten each bolt 1/4 turn in the order shown.
 - Repeat until quarter turns can no longer be achieved.
 - Complete the pattern two more times, torquing the bolts correctly.
 - Reset the torque wrench to **156 in-lbs** (13 ft-lbs or 17.6 Nm).
 - Repeat the pattern one more time and ensure that none of the bolts turn at this torque.
 - If they do turn at the lower torque, reset the wrench to **164 in-lbs** (13.7 ft-lbs or 18.5Nm) and repeat the previous steps.
26. Remove the two saw blade bolts used to hold the hub in place (inserted in step a). Do NOT reuse these bolts on a saw blade.
27. Use the snap ring pliers to install the snap ring onto the motor shaft snap ring groove (see Figure 7).

Figure 10: Exploded view of blade saw assembly

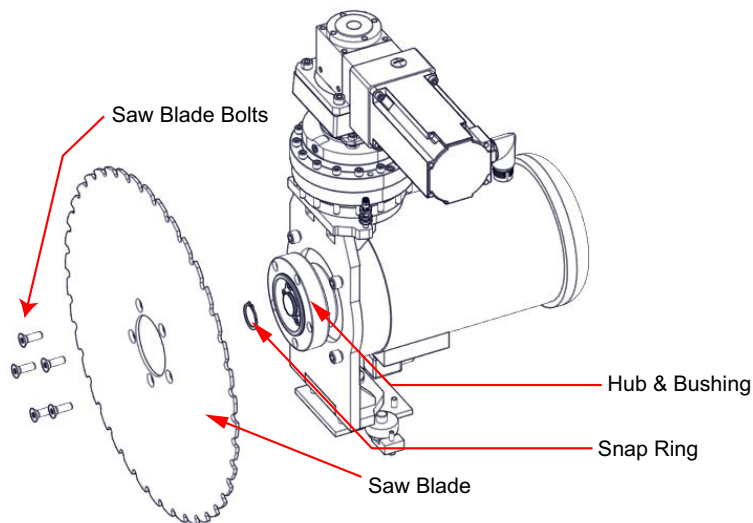

Installing the New Saw Blade

1. Clean the front and back of the saw blade so it mates flat against the hub.
2. Place the supplied new saw blade so the holes align with the holes in the hub and the teeth hook points downward when cutting a straight cut. See Figure 12 for correct orientation.
3. Using new bolts supplied in this kit, install all 5 bolts.
 - Use the T40 bit and bolts listed in *Parts Included*.
 - Do NOT use thread adhesive.
 - Hand tighten all 5 bolts in the order shown in Figure 11.
 - Using the supplied torque wrench, tighten the bolts in the order shown in Figure 11 until they all reach the recommended torque shown in Figure 12.
 - Once properly torqued, all bolts should sit flush with the surface of the blade. If the bolts are protruding or skewed, repeat step 3 with new bolts.
4. By hand, carefully rotate the blade to observe its motion. It should not have any significant wobble or vibration when rotating.

Figure 11: Tighten Saw Blade Bolts in This Pattern

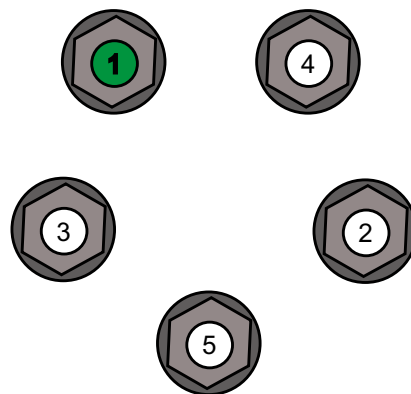
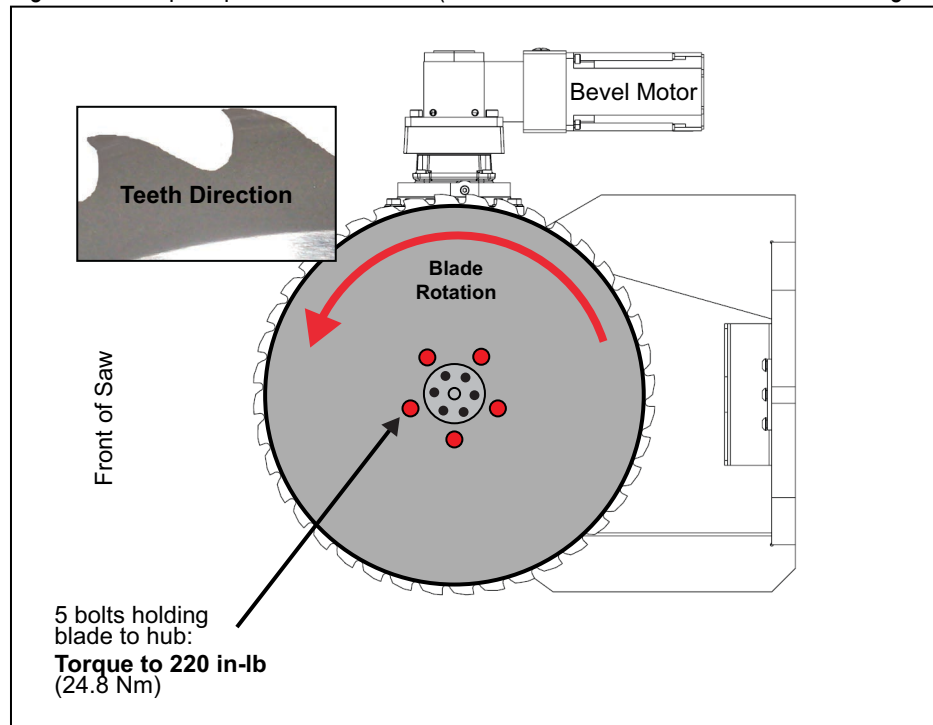

Figure 12: Torque Specs for Saw Blade (view from side of saw, with blade at 90 degrees)



5. Close the saw chamber door.
6. Power on machine:
 - a) Remove lockout/tagout and switch the disconnect switch to the ON position. See Figure 1.
 - b) Release E-stop and press Reset switch on the operator interface.
7. Use the machine software to start the saw blade rotation and observe its motion. It should not have any wobble or vibration when rotating.
8. Calibrate the stroke and LASM axes per your BLADE manual or MiTek website.

Returning Old Parts to MiTek

All obsolete components replaced during this procedure and ON HAND in your facility must be returned to MiTek.

Included in your service bulletin, there is a paper containing contact information for a MiTek Support Associate who will help you begin the return process. Please use existing packaging to return the items listed in Table 2. Note that some components removed during this procedure (hub, bushing, and snap ring) should still be attached to the motor and do not need to be removed.

See Figure 13 for examples of the previous hubs / bushings that may help identifying these components.

Table 2: Return Shipment List

Quantity	Description	Part #
All on hand	Motor	474176
All on hand	Hub for 1-piece hub (example below)	89433
All on hand	Bushing for 1-piece hub (example below)	547251
All on hand	Hub base for 2-piece hub (example below)	88823
All on hand	Hub snout for 2-piece hub (example below)	88824
All on hand	Bushing for 2-piece hub (example below)	547257
All on hand	Snap ring	379014
All on hand	Saw blade, 17"	811605
All on hand	Saw blade bolts, 1" long	325186

Figure 13: Examples of 1-piece and 2-piece Hub / Bushing

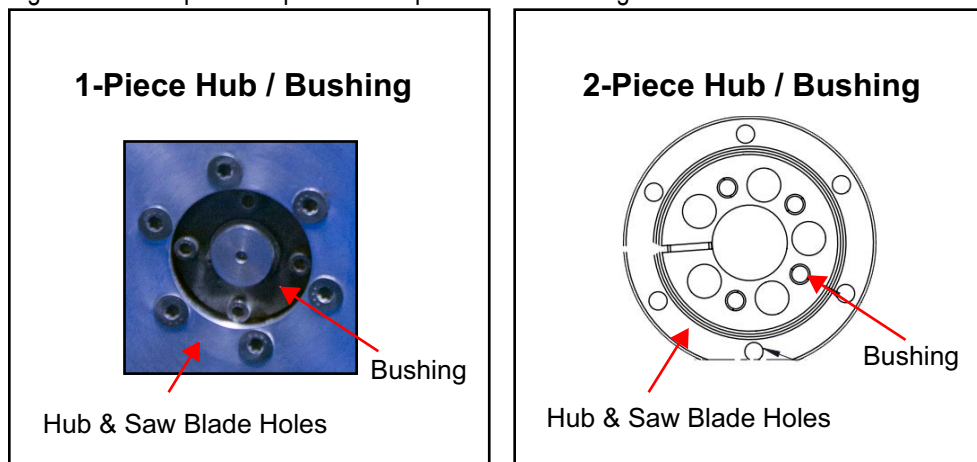

END OF SERVICE BULLETIN